

ELECTRICAL SYSTEM

SECTION **EL**

CONTENTS

PRECAUTIONS	4	System Description.....	59
Supplemental Restraint System (SRS) "AIR BAG" and "SEAT BELT PRE-TENSIONER".....	4	Wiring Diagram - H/AIM -	60
Wiring Diagrams and Trouble Diagnosis.....	4	PARKING, LICENSE AND TAIL LAMPS	61
HARNESS CONNECTOR	5	System Description.....	61
Description	5	Schematic	62
STANDARDIZED RELAY	7	Wiring Diagram - TAIL/L -	63
Description	7	Trouble Diagnoses.....	66
POWER SUPPLY ROUTING	9	STOP LAMP	67
Schematic	9	Wiring Diagram - STOP/L -	67
Wiring Diagram - POWER -	10	BACK-UP LAMP	69
Inspection.....	16	Wiring Diagram - BACK/L -	69
GROUND	17	FRONT FOG LAMP	70
Ground Distribution.....	17	System Description.....	70
COMBINATION SWITCH	28	Wiring Diagram - F/FOG -	72
Check.....	28	Aiming Adjustment	74
Replacement.....	29	TURN SIGNAL AND HAZARD WARNING LAMPS	75
STEERING SWITCH	30	System Description.....	75
Check.....	30	Wiring Diagram - TURN -	77
HEADLAMP (FOR USA) - XENON TYPE -	31	Trouble Diagnoses.....	79
Component Parts and Harness Connector		Electrical Components Inspection	79
Location	31	ILLUMINATION	80
System Description.....	31	System Description.....	80
Schematic	35	Schematic	82
Wiring Diagram - H/LAMP -	36	Wiring Diagram - ILL -	83
Trouble Diagnoses.....	40	INTERIOR, SPOT, VANITY MIRROR AND LUGGAGE ROOM LAMPS	88
Bulb Replacement/Xenon Type	43	System Description.....	88
Aiming Adjustment.....	44	Schematic	90
HEADLAMP (FOR CANADA) - DAYTIME LIGHT SYSTEM -	46	Wiring Diagram - INT/L -	91
Component Parts and Harness Connector		METERS AND GAUGES	94
Location	46	Component Parts and Harness Connector	
System Description.....	46	Location	94
Schematic	50	System Description.....	94
Wiring Diagram - DTRL -	51	Combination Meter	96
Trouble Diagnoses.....	56	Schematic	98
Bulb Replacement	57	Wiring Diagram - METER -	99
Aiming Adjustment.....	58	Meter/Gauge Operation and Odo/Trip Meter	
HEADLAMP - HEADLAMP AIMING CONTROL -	59	Segment Check in Diagnosis Mode.....	100
		Trouble Diagnoses.....	101

GI

MA

EM

LC

EC

FE

AT

TF

PD

AX

SU

BR

ST

RS

BT

HA

SC

EL

IDX

CONTENTS (Cont'd)

Electrical Components Inspection	108	Trouble Diagnoses.....	166
COMPASS AND THERMOMETER	110	Inspection.....	167
System Description.....	110	Wiring Diagram - REMOTE -	168
Wiring Diagram - COMPAS -	111	AUDIO ANTENNA	169
Trouble Diagnoses.....	112	System Description.....	169
Calibration Procedure for Compass	113	Wiring Diagram - P/ANT -	170
WARNING LAMPS	114	Trouble Diagnoses.....	171
Schematic	114	Location of Antenna.....	171
Wiring Diagram - WARN -	115	Antenna Rod Replacement	171
Fuel Warning Lamp Sensor Check	122	POWER SUNROOF	173
Electrical Components Inspection	122	System Description.....	173
A/T INDICATOR	123	Wiring Diagram - SROOF -	174
Wiring Diagram - AT/IND -	123	Trouble Diagnoses.....	176
WARNING CHIME	125	DOOR MIRROR	177
Component Parts and Harness Connector		Wiring Diagram - MIRROR -	177
Location	125	GLASS HATCH OPENER	178
System Description.....	125	System Description.....	178
Wiring Diagram - CHIME -	127	Wiring Diagram - TLID -	179
Trouble Diagnoses.....	129	FUEL FILLER LID OPENER	180
FRONT WIPER AND WASHER	136	Wiring Diagram - F/LID -	180
System Description.....	136	POWER SEAT	181
Wiring Diagram - WIPER -	138	Wiring Diagram - SEAT -	181
Removal and Installation	139	HEATED SEAT	183
Washer Nozzle Adjustment	140	Wiring Diagram - HSEAT -	183
Washer Tube Layout	140	Seatback Heating Unit.....	185
REAR WIPER AND WASHER	141	AUTOMATIC DRIVE POSITIONER	186
System Description.....	141	Component Parts and Harness Connector	
Wiring Diagram - WIP/R -	143	Location	186
Trouble Diagnoses.....	145	System Description.....	187
Removal and Installation	145	Schematic	190
Washer Nozzle Adjustment	146	Wiring Diagram - AUT/DP -	191
Washer Tube Layout	146	On Board Diagnosis	196
Check Valve.....	146	Trouble Diagnoses.....	198
HORN	147	AUTOMATIC SPEED CONTROL DEVICE (ASCD) ...	221
Wiring Diagram - HORN -	147	Component Parts and Harness Connector	
CIGARETTE LIGHTER	148	Location	221
Wiring Diagram - CIGAR -	148	System Description.....	222
CLOCK	150	Schematic	224
Wiring Diagram - CLOCK -	150	Wiring Diagram - ASCD -	225
REAR WINDOW DEFOGGER	151	Fail-safe System.....	229
Component Parts and Harness Connector		Trouble Diagnoses.....	230
Location	151	Electrical Component Inspection.....	239
System Description.....	151	ASCDC Wire Adjustment	240
Wiring Diagram - DEF -	153	POWER WINDOW	241
Trouble Diagnoses.....	155	System Description.....	241
Electrical Components Inspection	157	Schematic	244
Filament Check.....	157	Wiring Diagram - WINDOW -	245
Filament Repair	158	Trouble Diagnoses.....	250
AUDIO	160	POWER DOOR LOCK	254
System Description.....	160	Component Parts and Harness Connector	
Schematic	161	Location	254
Wiring Diagram - AUDIO -	162	System Description.....	254

CONTENTS (Cont'd)

Schematic	255	System Description	350	GI
Wiring Diagram - D/LOCK -	256	Schematic	358	
Trouble Diagnoses	261	Wiring Diagram - IVCS -	359	MA
MULTI-REMOTE CONTROL SYSTEM	270	CONSULT-II	363	
Component Parts and Harness Connector		Trouble Diagnoses	368	EM
Location	270	Trouble Diagnoses for Intermittent Incident	377	
System Description	270	Demonstration Mode	379	EM
Schematic	273	System Setting (When IVCS Unit is Replaced)	381	
Wiring Diagram - MULTI -	274	NAVIGATION SYSTEM	385	LC
Trouble Diagnoses	277	Component Parts Location	385	
ID Code Entry Procedure	289	System Description	386	EC
Remote Controller Battery Replacement	293	Schematic	393	
THEFT WARNING SYSTEM	294	Wiring Diagram - NAVI -	394	FE
Component Parts and Harness Connector		Self-diagnosis Mode	397	
Location	294	Confirmation/Adjustment Mode	400	FE
System Description	295	Setting Mode	410	
Schematic	298	Trouble diagnoses	417	AT
Wiring Diagram - THEFT -	300	This Condition is Not Abnormal	423	
Trouble Diagnoses	306	Program Loading	432	TF
SMART ENTRANCE CONTROL UNIT	319	Initialization	433	
Description	319	ELECTRICAL UNITS LOCATION	436	PD
Schematic	322	Engine Compartment	436	
Smart Entrance Control Unit Inspection Table	324	Passenger Compartment	438	PD
INTEGRATED HOMELINK TRANSMITTER	325	HARNES LAYOUT	440	AX
Wiring Diagram - TRNSMT -	325	How to Read Harness Layout	440	
Trouble Diagnoses	326	Outline	441	AX
IVIS (INFINITI VEHICLE IMMOBILIZER SYSTEM - NATS)	328	Main Harness	442	SU
Component Parts and Harness Connector		Engine Room Harness	444	
Location	328	Engine Control Harness	446	BR
System Description	329	Body Harness LH	448	
System Composition	329	Body Harness RH	449	BR
Wiring Diagram - NATS -	330	Back Door Harness	450	
CONSULT-II	331	Engine and Transmission Harness	451	ST
Trouble Diagnoses	334	Room Lamp Harness	452	
How to Replace IVIS (NATS) IMMU	347	Air Bag Harness	453	RS
INFINITI COMMUNICATOR (IVCS)	348	Front Door Harness	454	
Precaution	348	Rear Door Harness	455	RS
Communicator Response Center Telephone		BULB SPECIFICATIONS	456	BT
Number for Technicians	348	Headlamp	456	
Component Parts and Harness Connector		Exterior Lamp	456	HA
Location	349	Interior Lamp	456	
		WIRING DIAGRAM CODES (CELL CODES)	457	HA

SC

EL

IDX

PRECAUTIONS

Supplemental Restraint System (SRS) "AIR BAG" and "SEAT BELT PRE-TENSIONER"

Supplemental Restraint System (SRS) "AIR BAG" and "SEAT BELT PRE-TENSIONER"

NBEL0001

The Supplemental Restraint System such as "AIR BAG" and "SEAT BELT PRE-TENSIONER" used along with a seat belt, helps to reduce the risk or severity of injury to the driver and front passenger for certain types of collision. The SRS system composition which is available to INFINITI QX4 is as follows:

- For a frontal collision
The Supplemental Restraint System consists of driver air bag module (located in the center of the steering wheel), front passenger air bag module (located on the instrument panel on passenger side), seat belt pre-tensioners, a diagnosis sensor unit, warning lamp, wiring harness and spiral cable.
- For a side collision
The Supplemental Restraint System consists of side air bag module (located in the outer side of front seat), satellite sensor, diagnosis sensor unit (one of components of air bags for a frontal collision), wiring harness, warning lamp (one of components of air bags for a frontal collision).

Information necessary to service the system safely is included in the **RS section** of this Service Manual.

WARNING:

- **To avoid rendering the SRS inoperative, which could increase the risk of personal injury or death in the event of a collision which would result in air bag inflation, all maintenance must be performed by an authorized INFINITI dealer.**
- **Improper maintenance, including incorrect removal and installation of the SRS, can lead to personal injury caused by unintentional activation of the system. For removal of Spiral Cable and Air Bag Module, see the RS section.**
- **Do not use electrical test equipment on any circuit related to the SRS unless instructed to in this Service Manual. Spiral cable and wiring harnesses covered with yellow insulation tape either just before the harness connectors or for the complete harness are related to the SRS.**

Wiring Diagrams and Trouble Diagnosis

NBEL0002

When you read wiring diagrams, refer to the following:

- GI-11, "HOW TO READ WIRING DIAGRAMS"
- EL-9, "POWER SUPPLY ROUTING" for power distribution circuit

When you perform trouble diagnosis, refer to the following:

- GI-35, "HOW TO FOLLOW TEST GROUPS IN TROUBLE DIAGNOSES"
- GI-24, "HOW TO PERFORM EFFICIENT DIAGNOSIS FOR AN ELECTRICAL INCIDENT"

Check for any Service bulletins before servicing the vehicle.

Description

NBEL0003

NBEL0003S01

HARNESS CONNECTOR (TAB-LOCKING TYPE)

- The tab-locking type connectors help prevent accidental looseness or disconnection.
- The tab-locking type connectors are disconnected by pushing or lifting the locking tab(s). Refer to the illustration below.

Refer to the next page for description of the slide-locking type connector.

CAUTION:

Do not pull the harness when disconnecting the connector.

[Example]

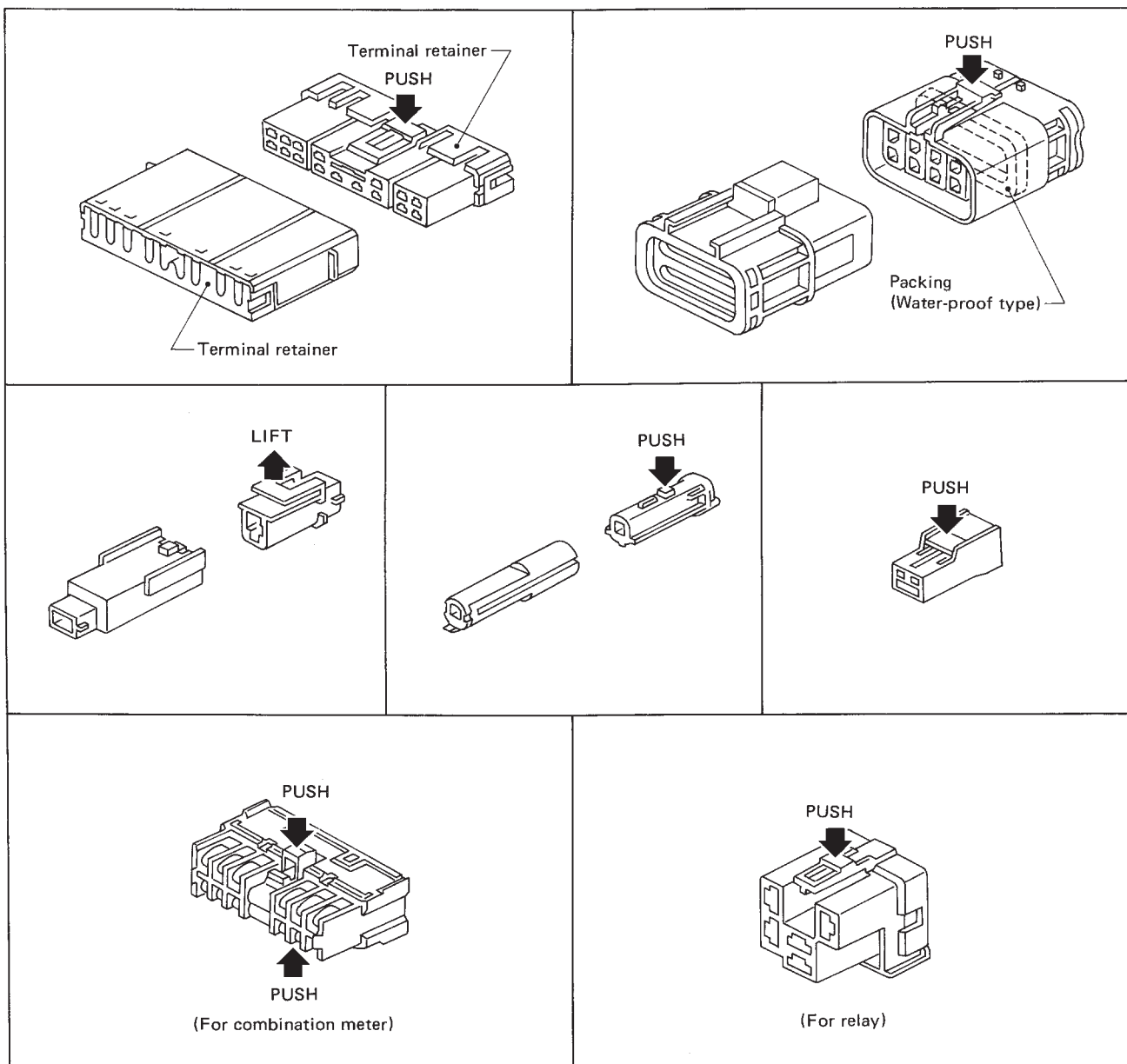

GI

MA

EM

LC

EC

FE

AT

TF

PD

AX

SU

BR

ST

RS

BT

HA

SC

EL

IDX

SEL769D

HARNESS CONNECTOR

Description (Cont'd)

HARNESS CONNECTOR (SLIDE-LOCKING TYPE)

=NBEL0003S02

- A new style slide-locking type connector is used on certain systems and components, especially those related to OBD.
- The slide-locking type connectors help prevent incomplete locking and accidental looseness or disconnection.
- The slide-locking type connectors are disconnected by pushing or pulling the slider. Refer to the illustration below.

CAUTION:

- Do not pull the harness or wires when disconnecting the connector.
- Be careful not to damage the connector support bracket when disconnecting the connector.

[Example]

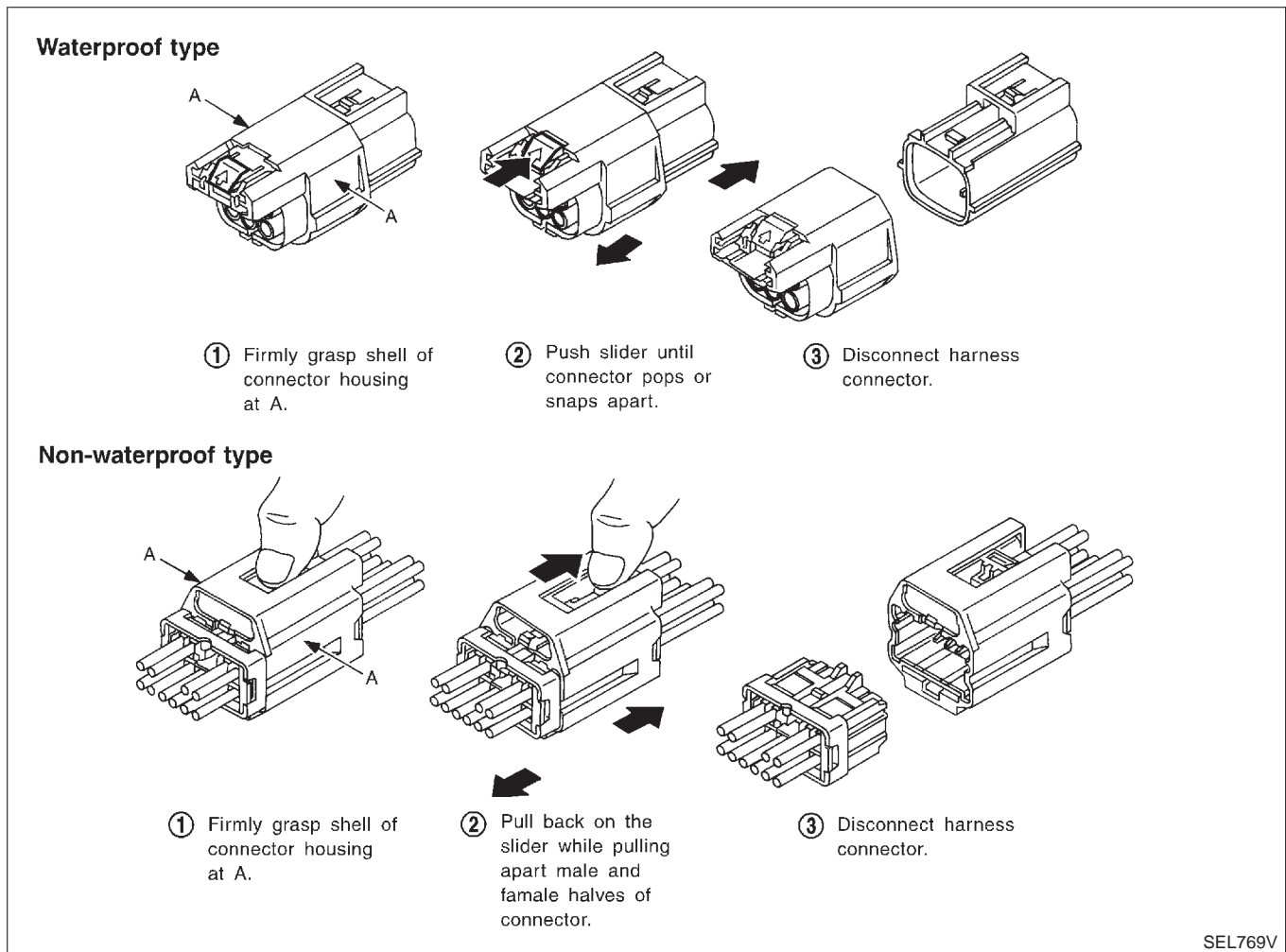

SEL769V

STANDARDIZED RELAY

Description

Description

NORMAL OPEN, NORMAL CLOSED AND MIXED TYPE RELAYS

Relays can mainly be divided into three types: normal open, normal closed and mixed type relays.

NBEL0004

NBEL0004S01

GI

MA

EM

LC

EC

FE

AT

TF

SEL881H

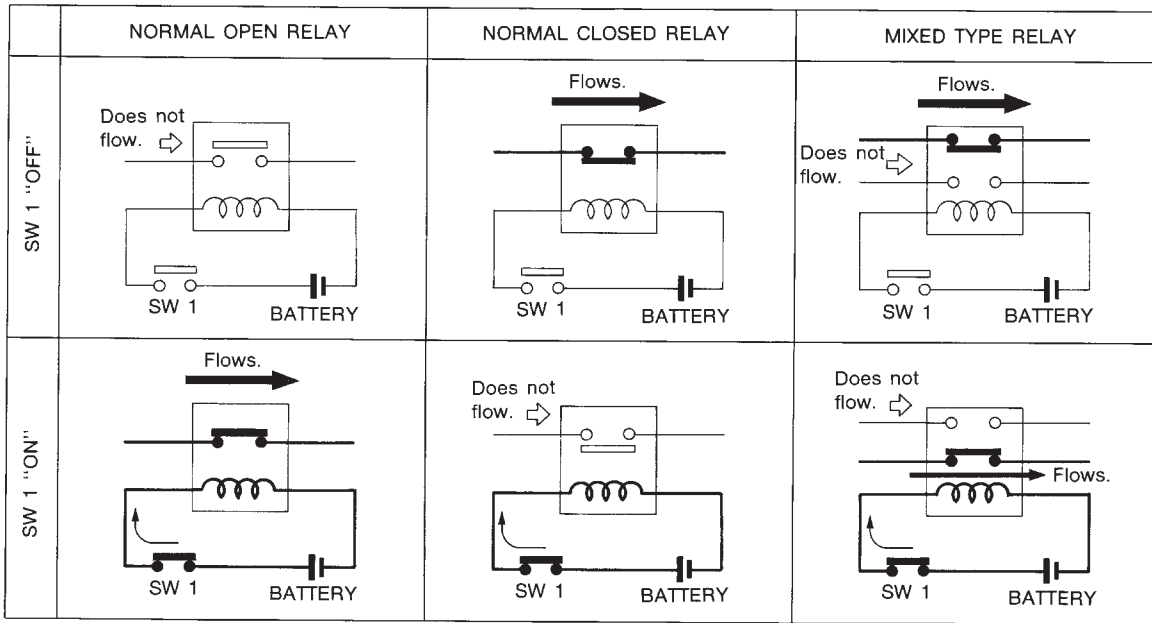

TYPE OF STANDARDIZED RELAYS

NBEL0004S02

1M	1 Make	2M	2 Make
1T	1 Transfer	1M·1B	1 Make 1 Break

PD

AX

SU

BR

ST

RS

BT

HA

SC

SEL882H

EL

IDX

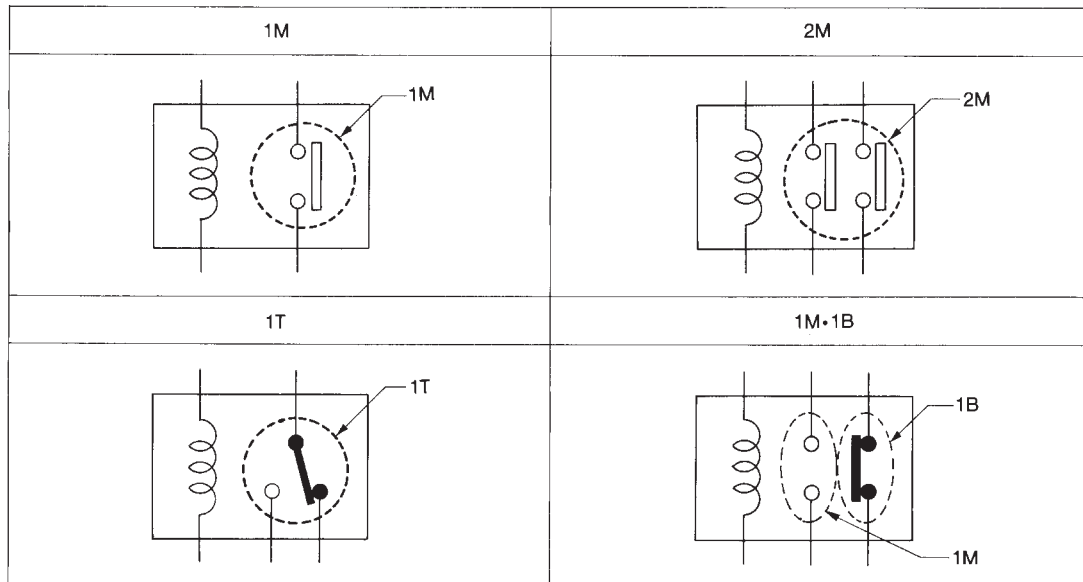

STANDARDIZED RELAY

Description (Cont'd)

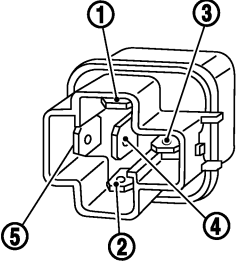
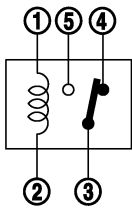
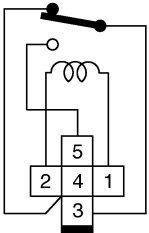
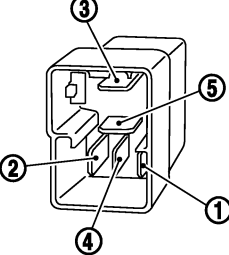
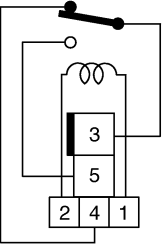
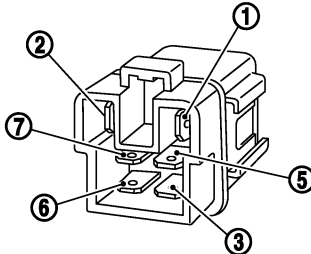
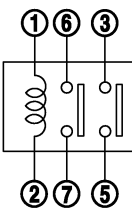
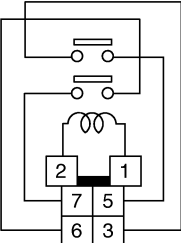
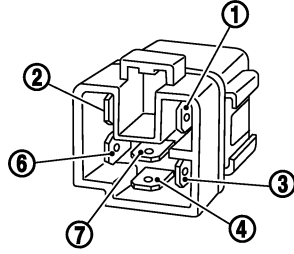
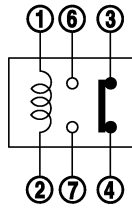
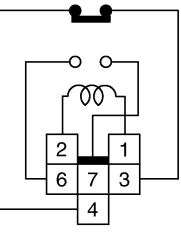
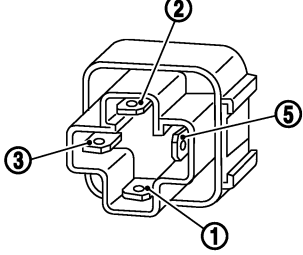
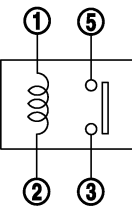
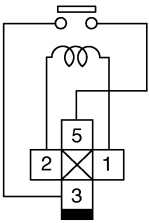
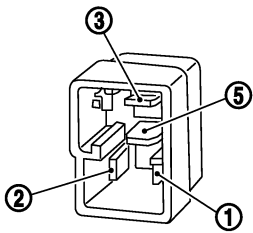
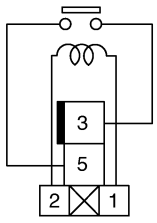
Type	Outer view	Circuit	Connector symbol and connector	Case color
1T				BLACK
				
2M				BROWN
1M•1B				GRAY
1M				BLUE
				

The arrangement of terminal numbers on the actual relays may differ from those shown above.

GEL264

POWER SUPPLY ROUTING

Schematic

NBEL0005

Schematic

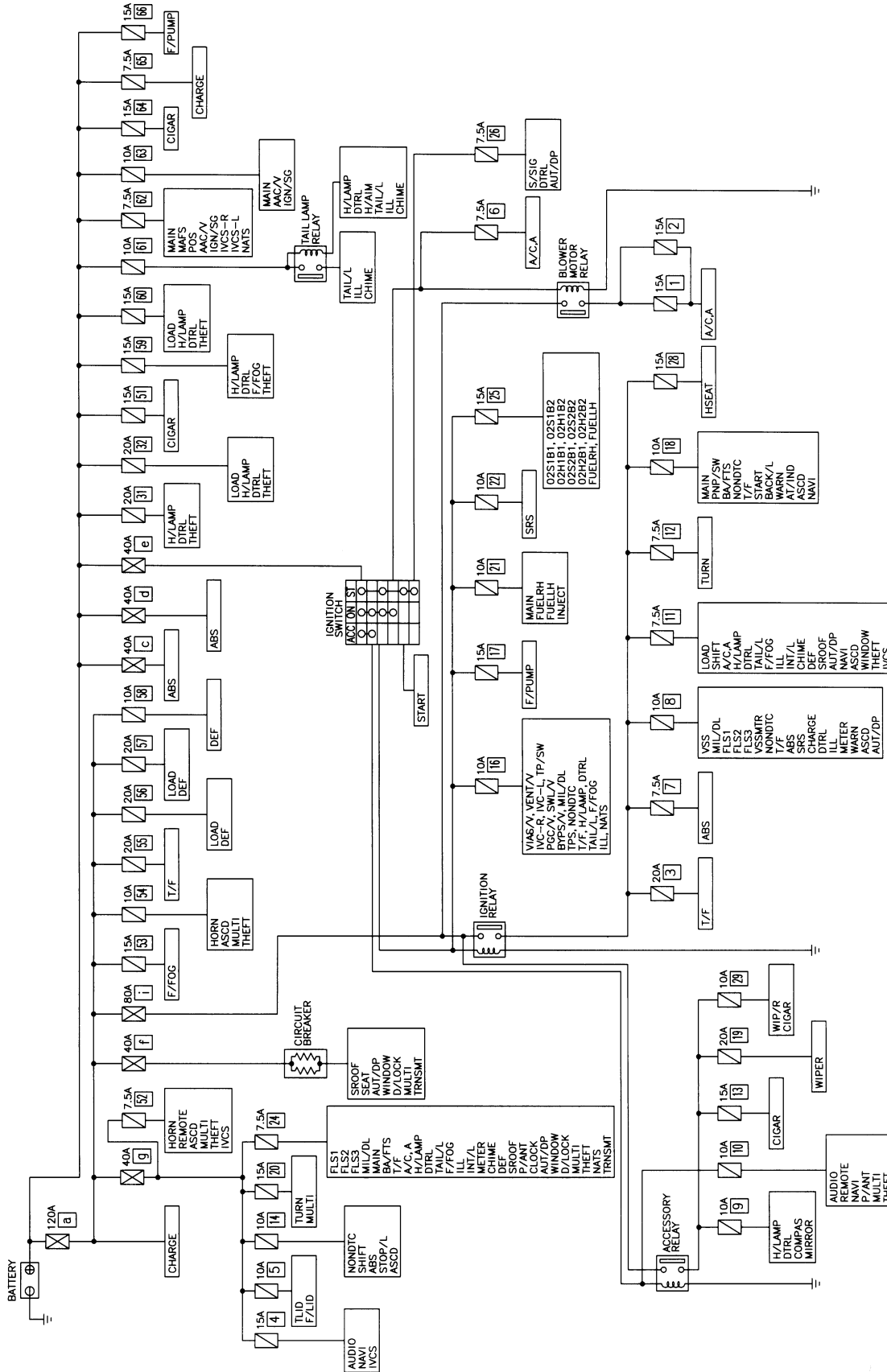

GI
MA
EM
LC
EC
FE
AT
TF
PD
AX
SU
BR
ST
RS
BT
HA
SC
EL
IDX

MEL754L

POWER SUPPLY ROUTING

Wiring Diagram — POWER —

Wiring Diagram — POWER —

BATTERY POWER SUPPLY — IGNITION SW. IN ANY POSITION

NBEL0006

NBEL0006S01

EL-POWER-01

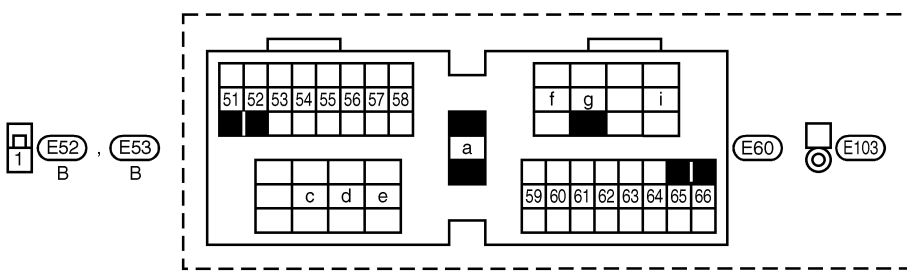
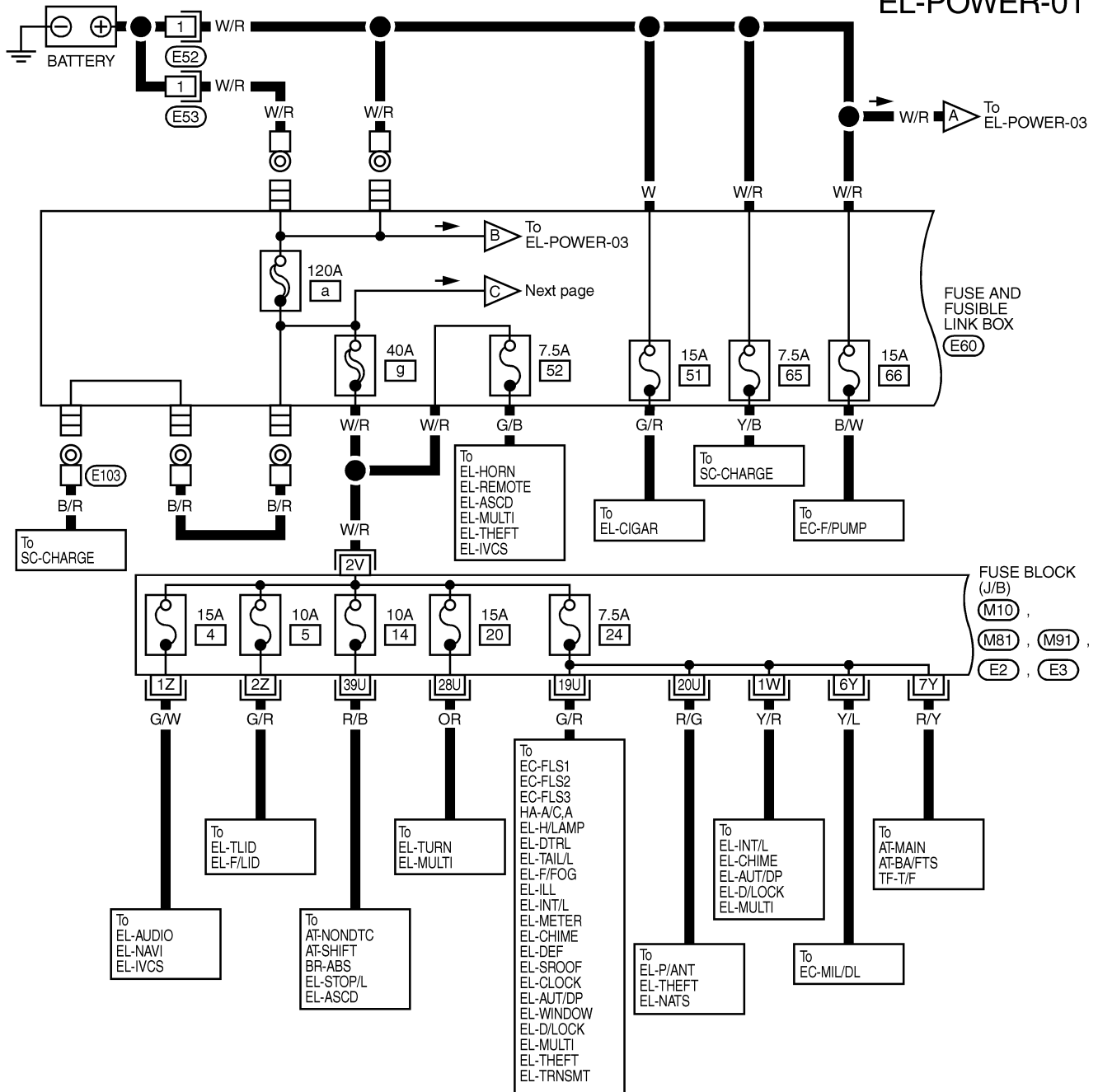

REFER TO THE FOLLOWING.

(M10), (M81), (M91),
(E2), (E3)

FUSE BLOCK-JUNCTION BOX (J/B)

1	2	3	4	5
6	7	8	9	10
11	12	13	14	15
16	17	18	19	20
21	22			
24	25	26		
	28	29		

MEL755L

POWER SUPPLY ROUTING

Wiring Diagram — POWER — (Cont'd)

EL-POWER-02

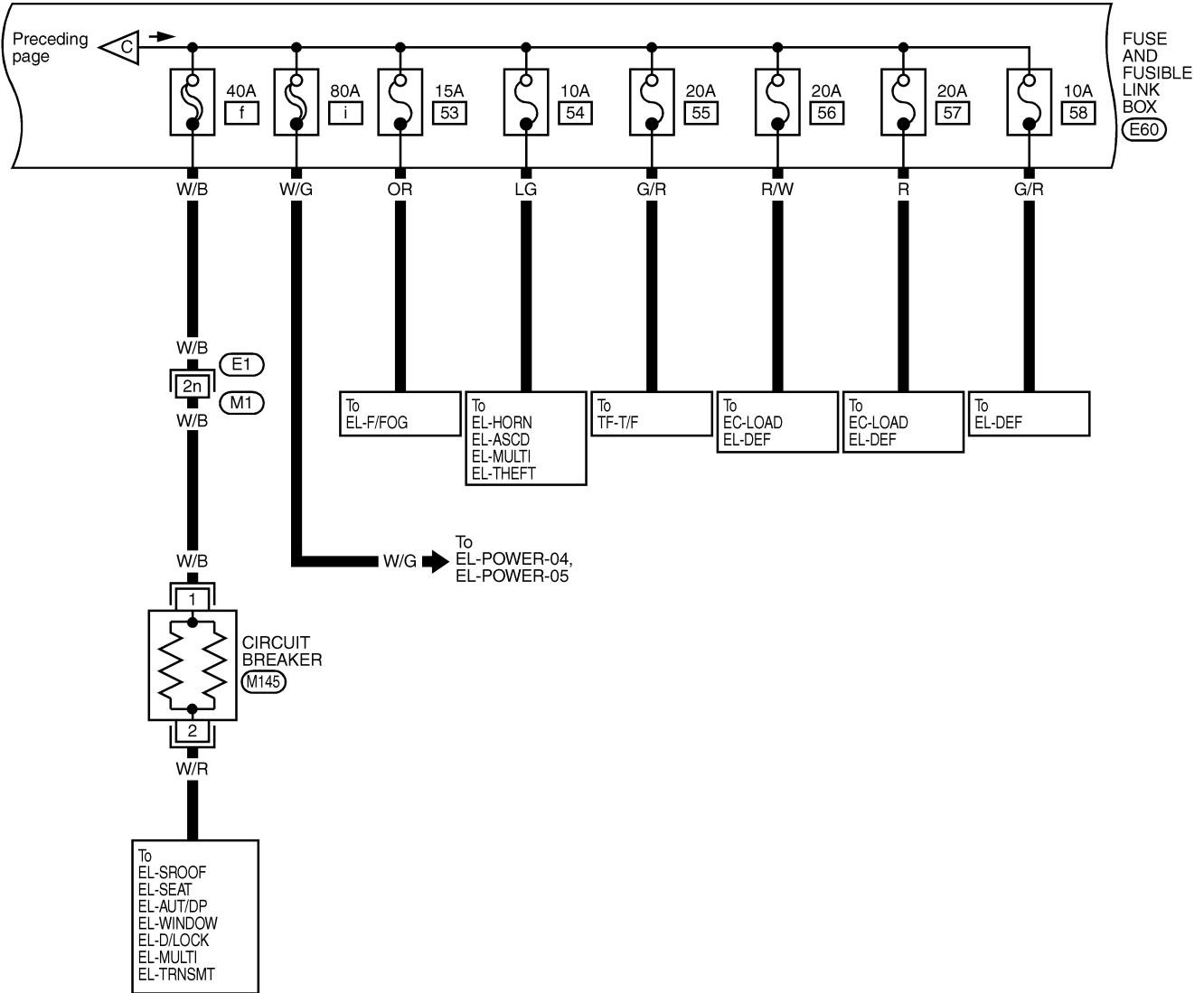

GI
MA
EM
LC
EC
FE
AT
TF
PD
AX
SU
BR
ST
RS
BT
HA
SC
EL
IDX

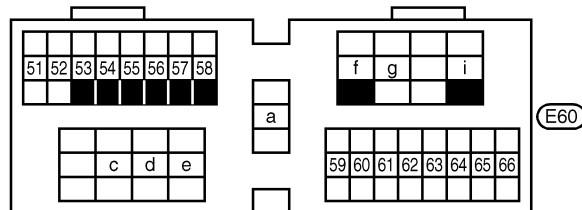
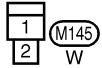

REFER TO THE FOLLOWING.
(E1) -SUPER
MULTIPLE JUNCTION (SMJ)

MEL756L

POWER SUPPLY ROUTING

Wiring Diagram — POWER — (Cont'd)

EL-POWER-03

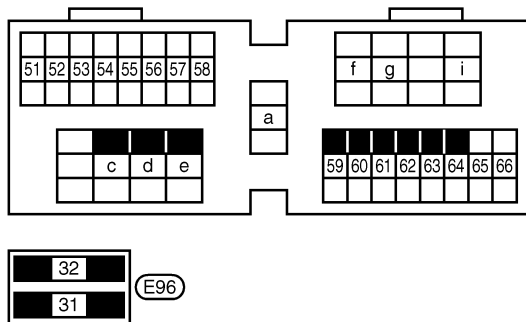
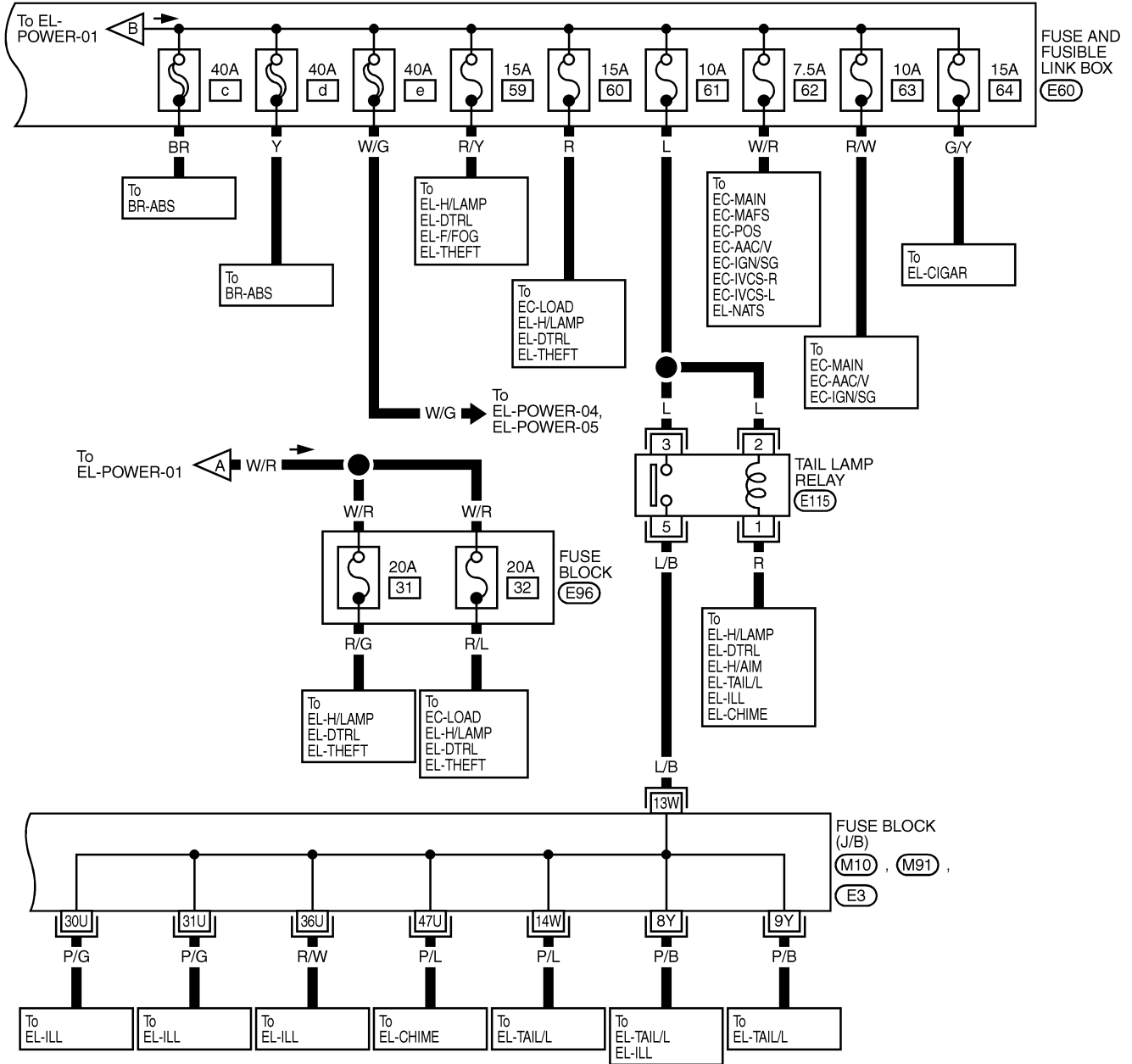

REFER TO THE FOLLOWING.

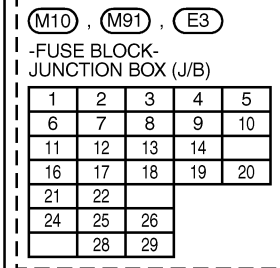

MEL757L

POWER SUPPLY ROUTING

Wiring Diagram — POWER — (Cont'd)

ACCESSORY POWER SUPPLY — IGNITION SW. IN “ACC” OR “ON”

NBEL0006S02

EL-POWER-04

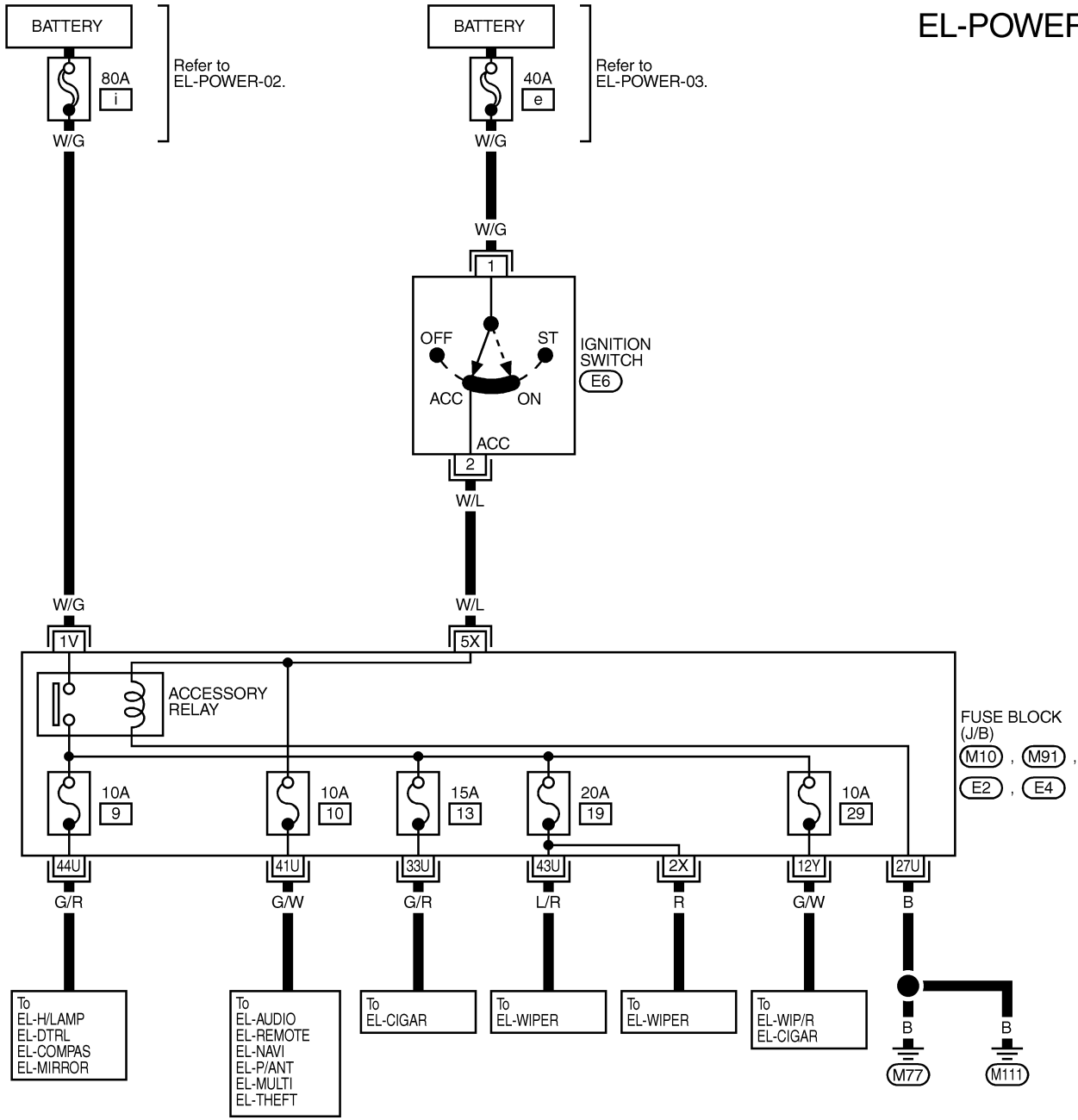

GI
MA
EM
LC
EC
FE
AT
TF
PD
AX
SU
BR
ST
RS
BT
HA
SC
EL
IDX

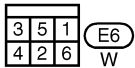

REFER TO THE FOLLOWING.

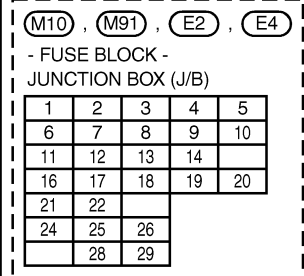

MEL758L

POWER SUPPLY ROUTING

Wiring Diagram — POWER — (Cont'd)

IGNITION POWER SUPPLY — IGNITION SW. IN “ON” AND/OR “START”

NBEL0006S03

EL-POWER-05

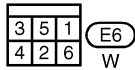
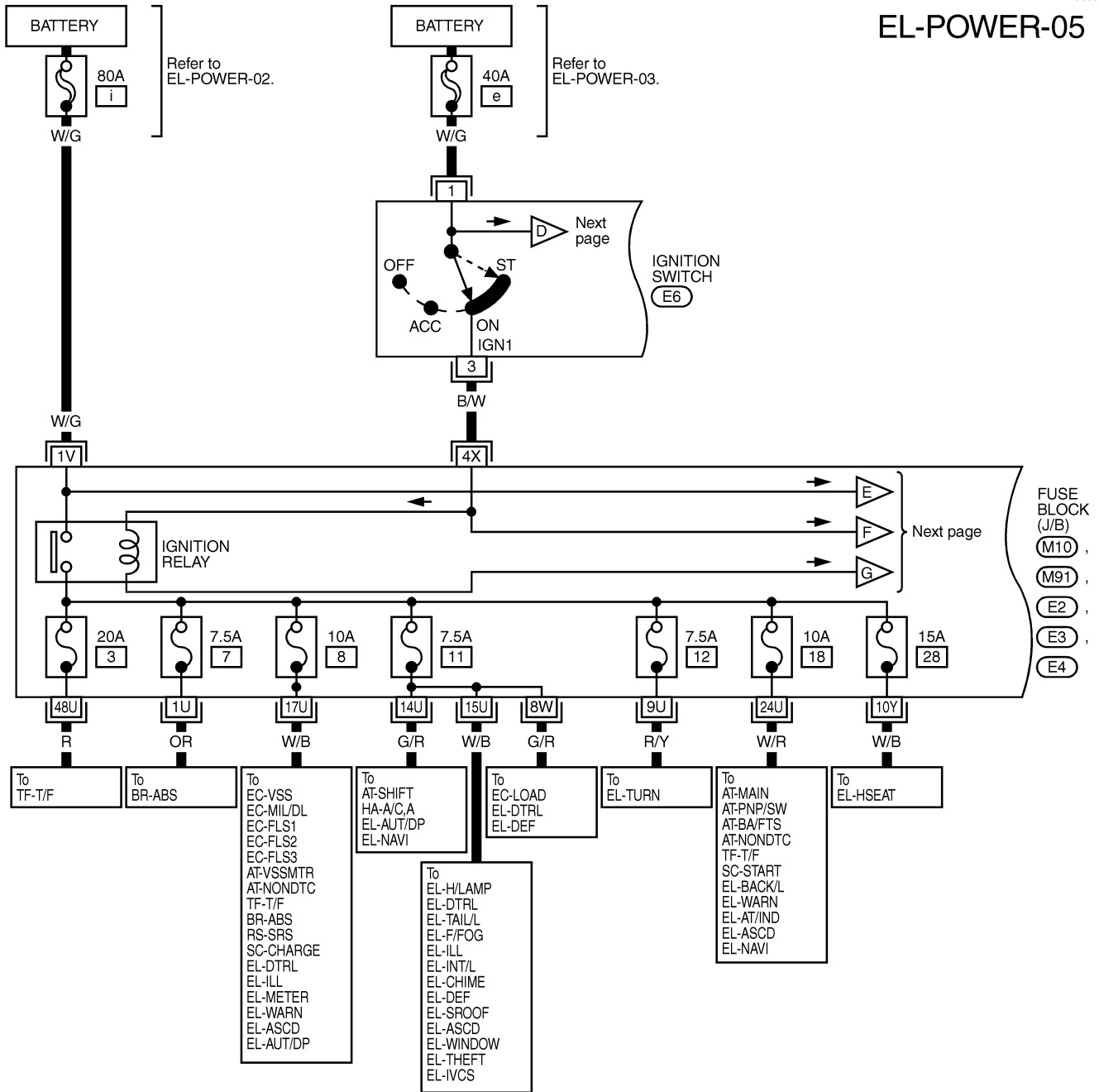

REFER TO THE FOLLOWING.

(M10) , (M91) , (E2) ,
(E3) , (E4)

- FUSE BLOCK-
JUNCTION BOX (J/B)

1	2	3	4	5
6	7	8	9	10
11	12	13	14	
16	17	18	19	20
21	22			
24	25	26		
	28	29		

MEL759L

POWER SUPPLY ROUTING

Wiring Diagram — POWER — (Cont'd)

EL-POWER-06

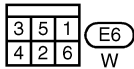
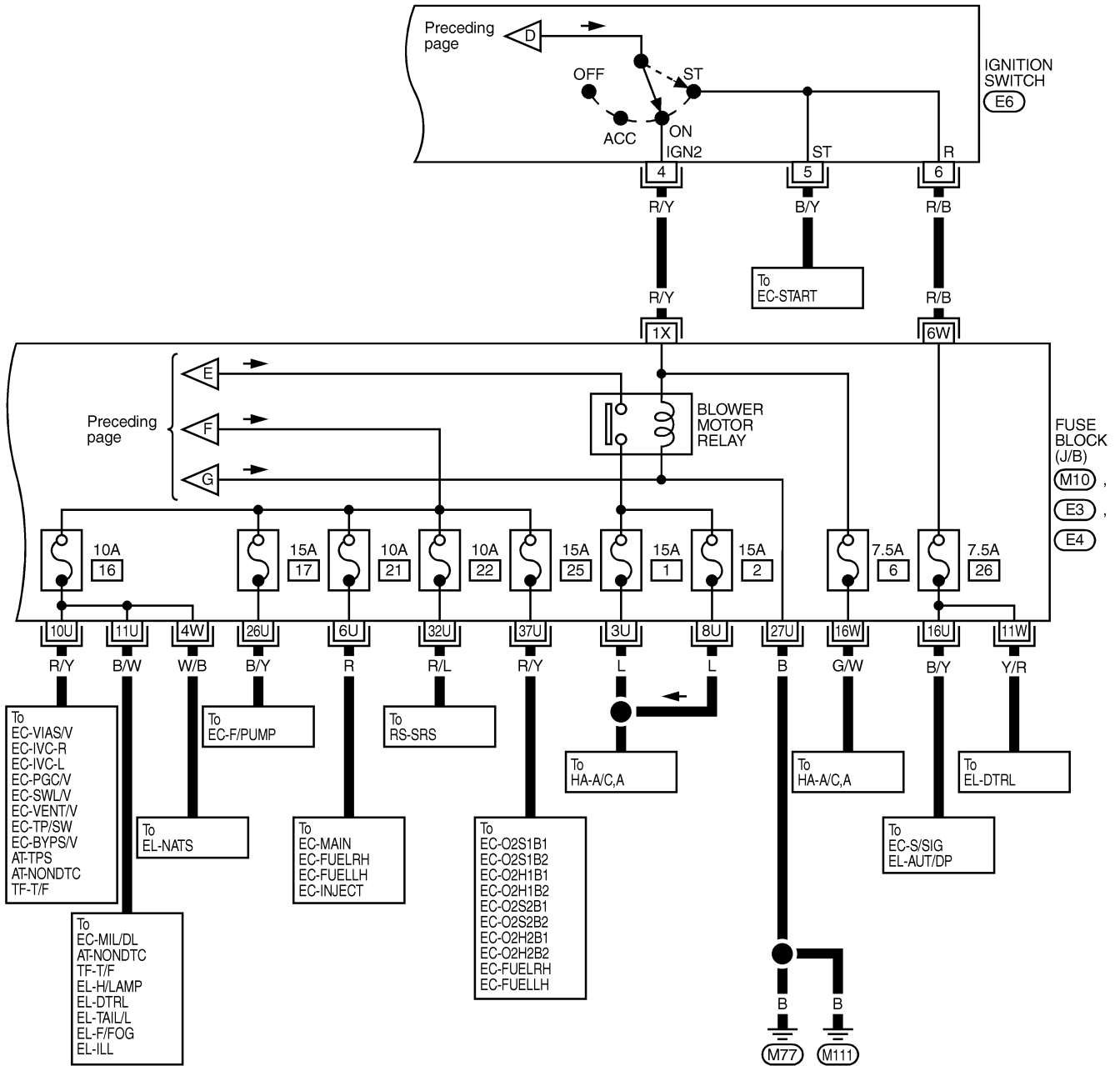

REFER TO THE FOLLOWING.

(M10), (E3), (E4)

- FUSE BLOCK - JUNCTION BOX (J/B)

1	2	3	4	5
6	7	8	9	10
11	12	13	14	
16	17	18	19	20
21	22			
24	25	26		
	28	29		

MEL760L

POWER SUPPLY ROUTING

Inspection

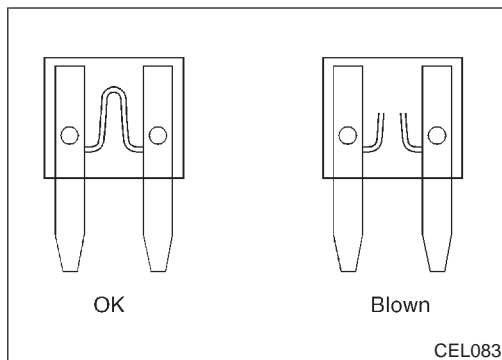

Inspection

FUSE

NBEL0007

NBEL0007S01

- If fuse is blown, be sure to eliminate cause of problem before installing new fuse.
- Use fuse of specified rating. Never use fuse of more than specified rating.
- Do not partially install fuse; always insert it into fuse holder properly.
- Remove fuse for “ELECTRICAL PARTS (BAT)” if vehicle is not used for a long period of time.

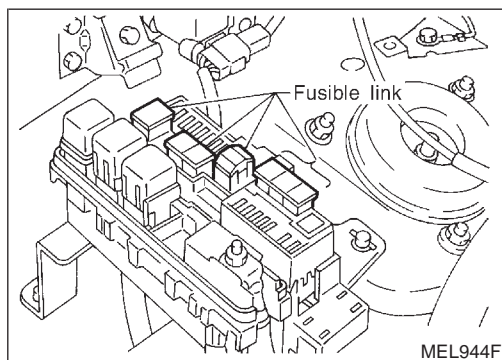

FUSIBLE LINK

NBEL0007S02

A melted fusible link can be detected either by visual inspection or by feeling with finger tip. If its condition is questionable, use circuit tester or test lamp.

CAUTION:

- If fusible link should melt, it is possible that critical circuit (power supply or large current carrying circuit) is shorted. In such a case, carefully check and eliminate cause of problem.
- Never wrap outside of fusible link with vinyl tape. Important: Never let fusible link touch any other wiring harness, vinyl or rubber parts.

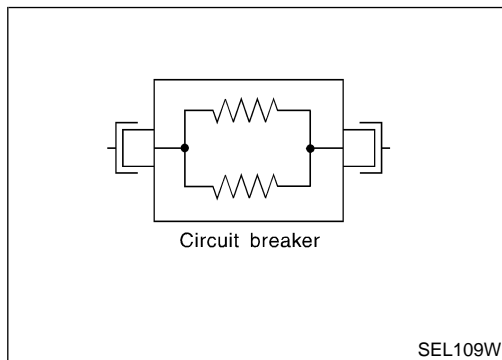

CIRCUIT BREAKER (PTC THERMISTOR TYPE)

NBEL0007S03

The PTC thermistor generates heat in response to current flow. The temperature (and resistance) of the thermistor element varies with current flow. Excessive current flow will cause the element's temperature to rise. When the temperature reaches a specified level, the electrical resistance will rise sharply to control the circuit current.

Reduced current flow will cause the element to cool. Resistance falls accordingly and normal circuit current flow is allowed to resume.

Ground Distribution

MAIN HARNESS

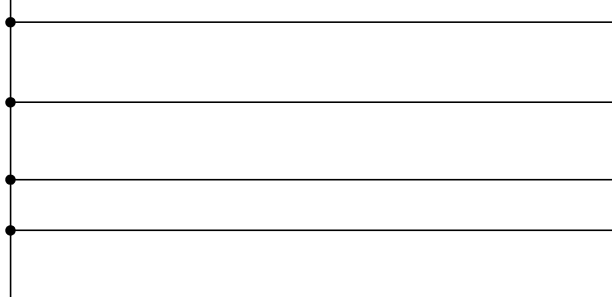
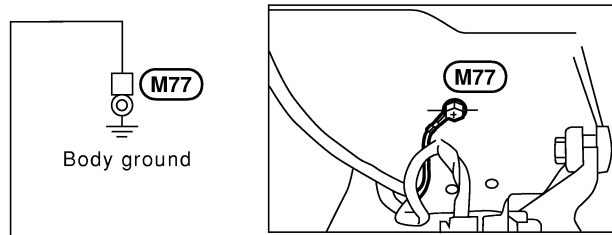

CON-NECTOR NUMBER	CONNECT TO
M9	Data link connector (Terminal No. 4)
M10	Fuse block (J/B) • Accessory relay • Blower motor relay • Ignition relay
M19	Illumination control switch
M26	Combination meter (Terminal No. 65) • Meter and odo/trip illumination

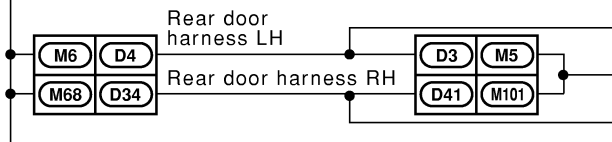

D12	Front door speaker LH
M48	Shield wire (Audio unit)
D42	Front door speaker RH

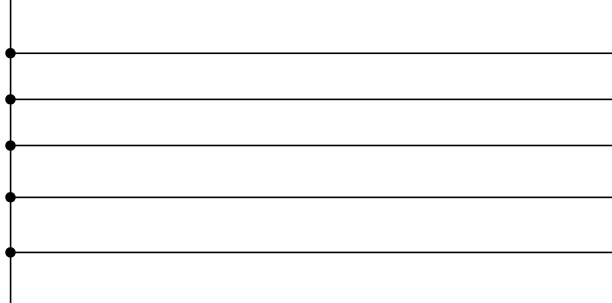

M56	Cigarette lighter socket
M60	Fan control amp.
M78	Front wiper motor
M115	Headlamp battery saver control unit (Terminal No. 4)
M121	Smart entrance control unit

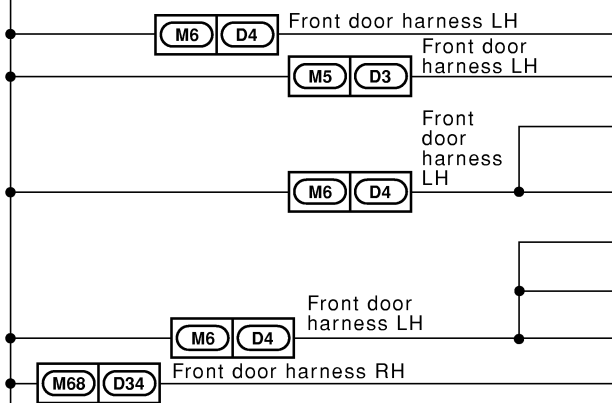

D1	Door mirror defogger LH
D7	Front door lock actuator LH
D14	Fuel filler lid and glass hatch opener switch (Terminal No. 1)
D14	Fuel filler lid and glass hatch opener switch (Terminal No. 3)
D6	Front power window main switch
D9	Front door key cylinder switch LH
D16	Seat memory switch
D37	Front door lock actuator RH

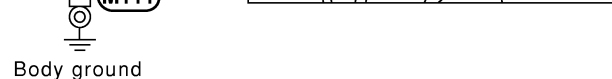
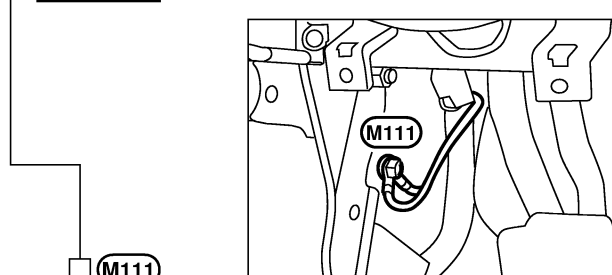

Body ground

MEL142M

GI
MA
EM
LC
EC
FE
AT
TF
PD
AX
SU
BR
ST
RS
BT
HA
SC
EL
IDX

GROUND

Ground Distribution (Cont'd)

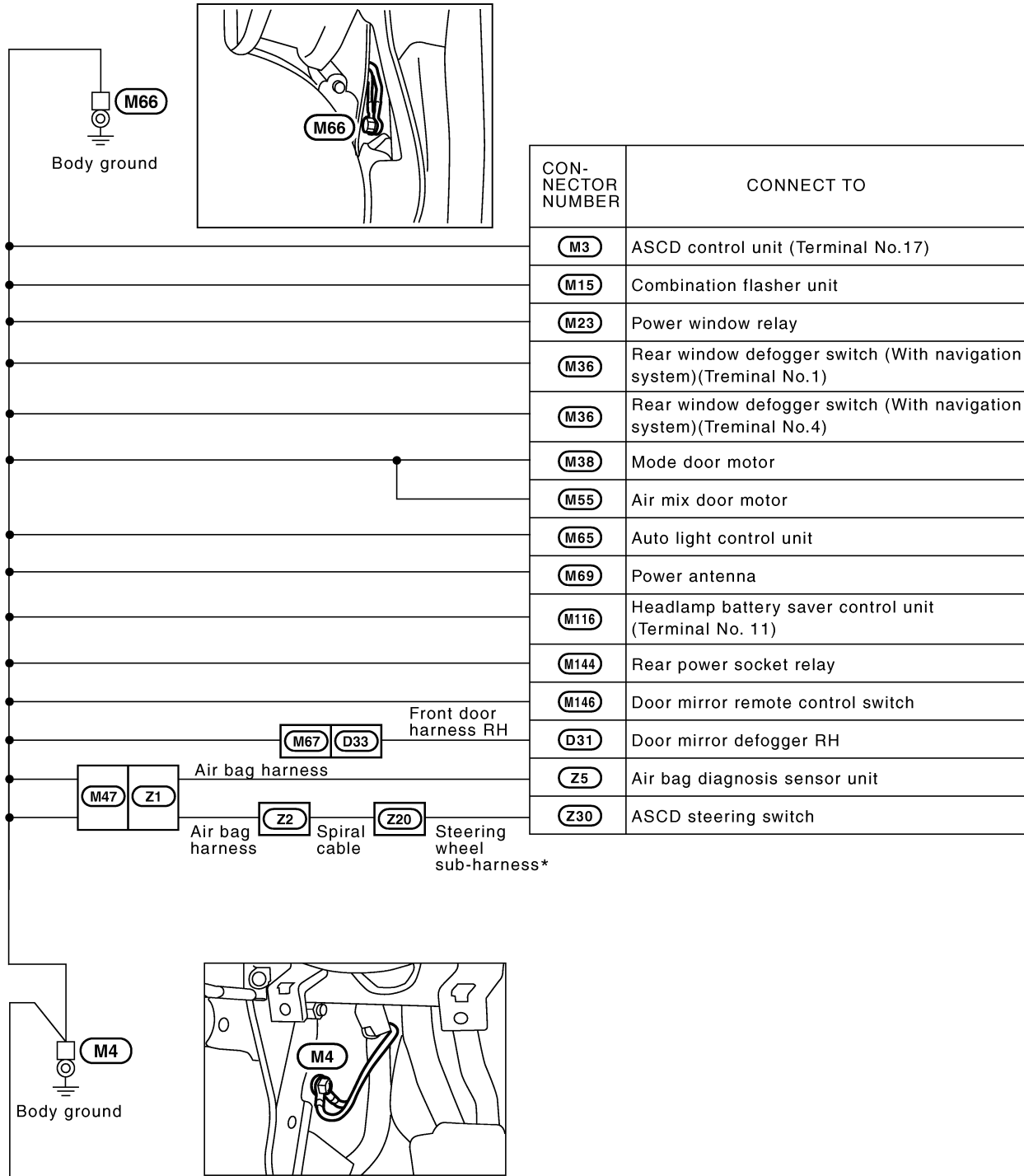

A Next page

*: This sub-harness is not shown in "Harness Layout", EL section.

MEL143M

GROUND

Ground Distribution (Cont'd)

A Preceding page

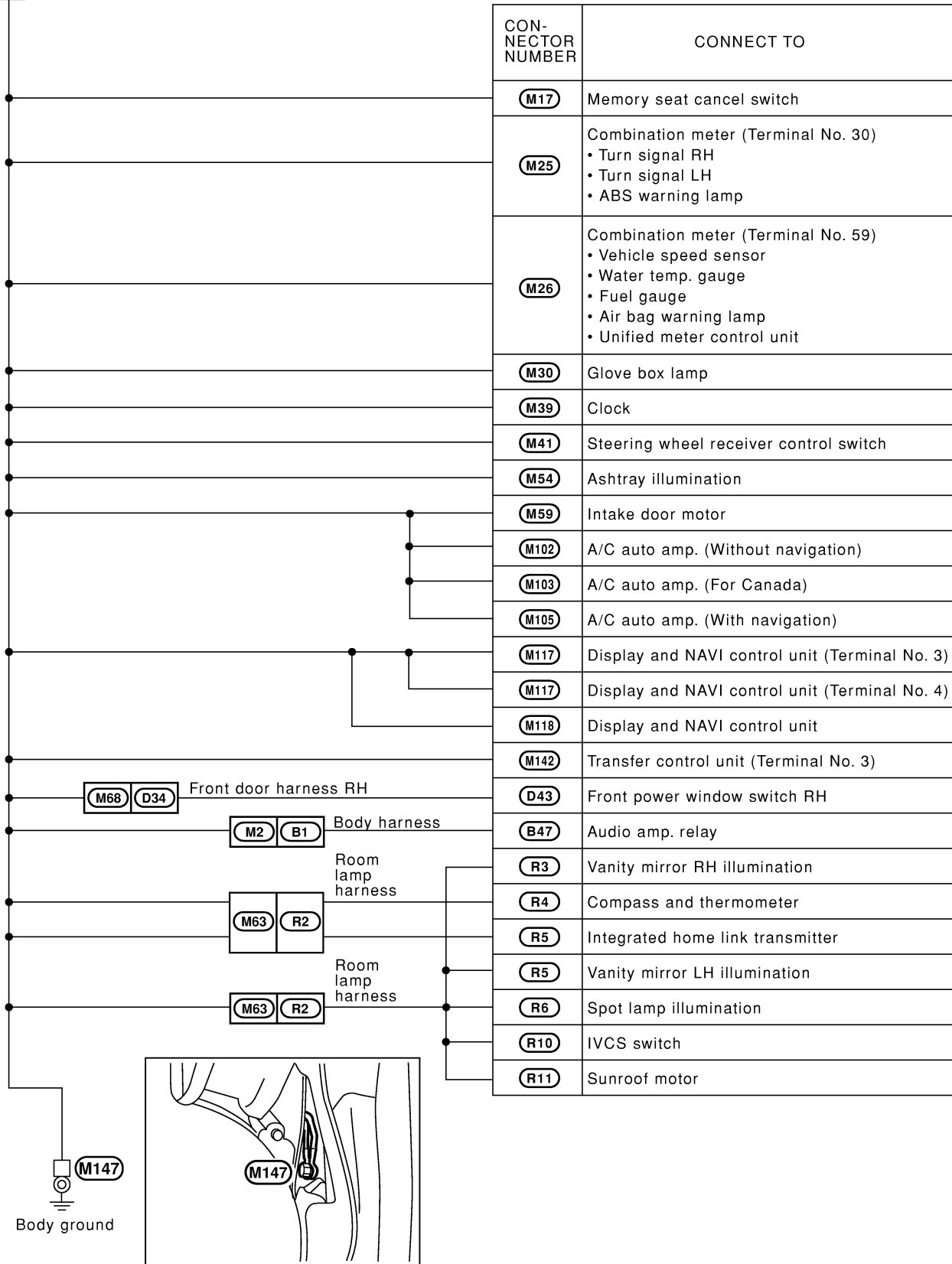

GI
MA
EM
LC
EC
FE
AT
TF
PD
AX
SU
BR
ST
RS
BT
HA
SC
EL
IDX

MEL144M

GROUND

Ground Distribution (Cont'd)

ENGINE ROOM HARNESS

NBEL0008S02

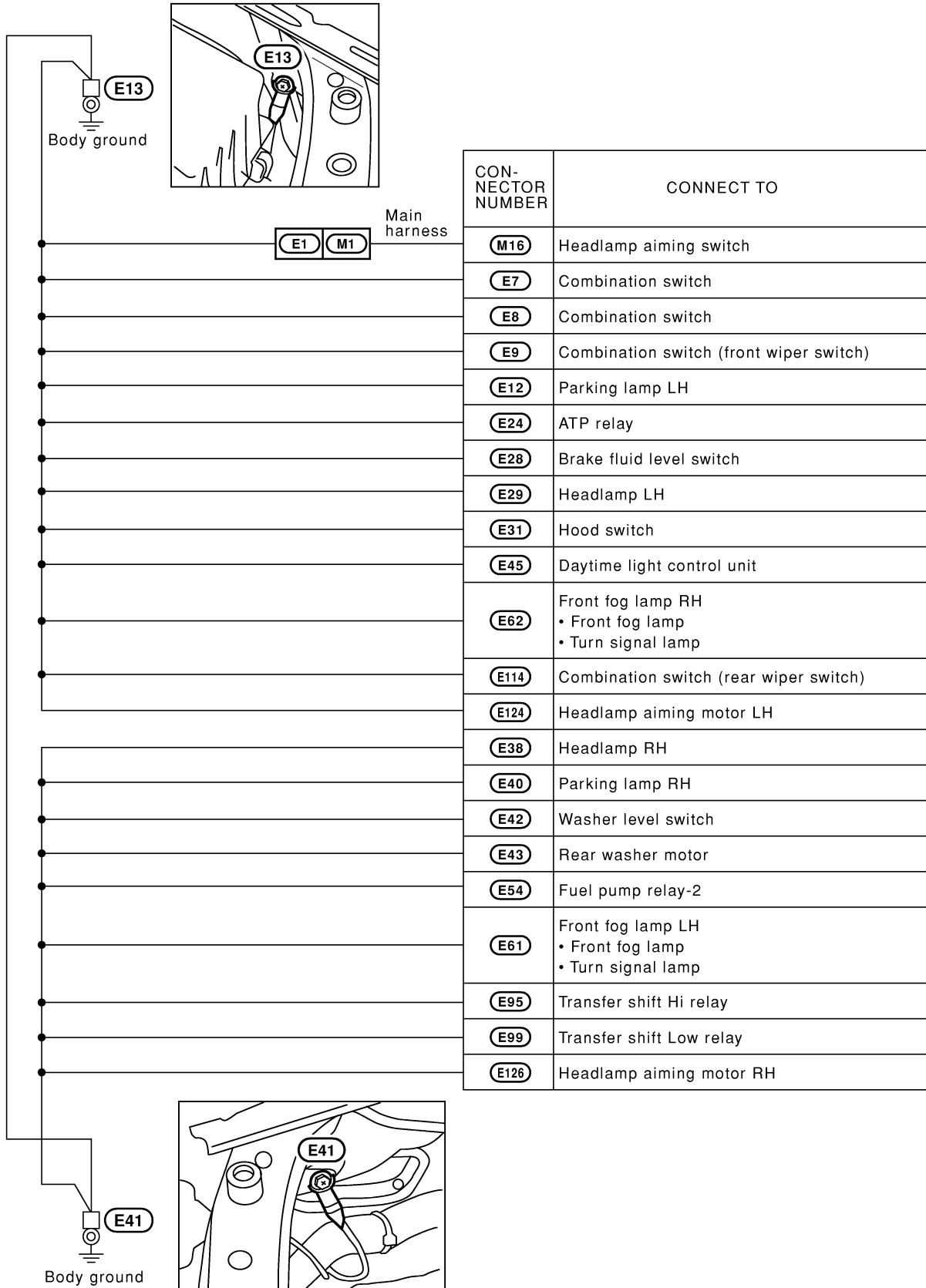

MEL418N

GROUND

Ground Distribution (Cont'd)

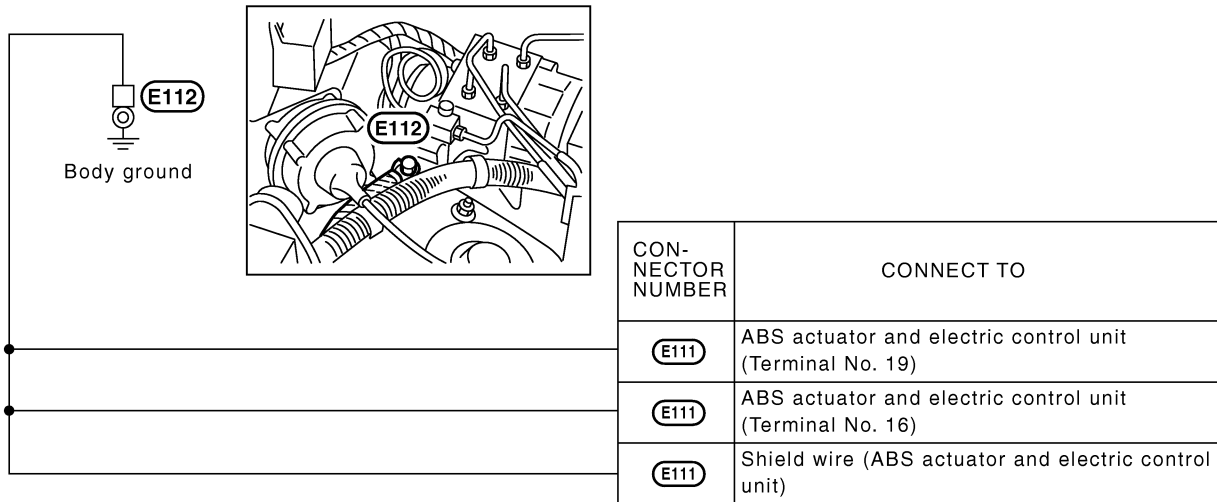
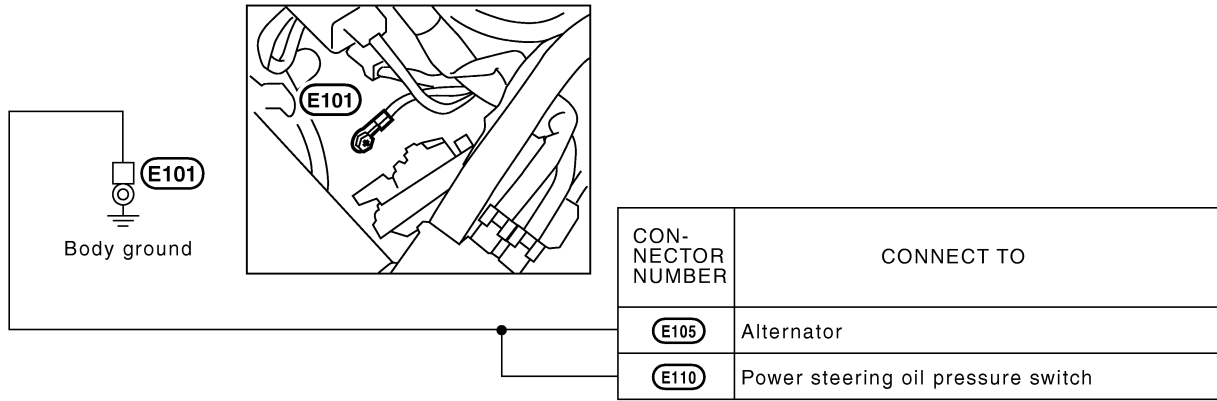

GI

MA

EM

LC

EC

FE

AT

TF

PD

AX

SU

BR

ST

RS

BT

HA

SC

EL

IDX

MEL146M

GROUND

Ground Distribution (Cont'd)

ENGINE CONTROL HARNESS

NBEL0008S03

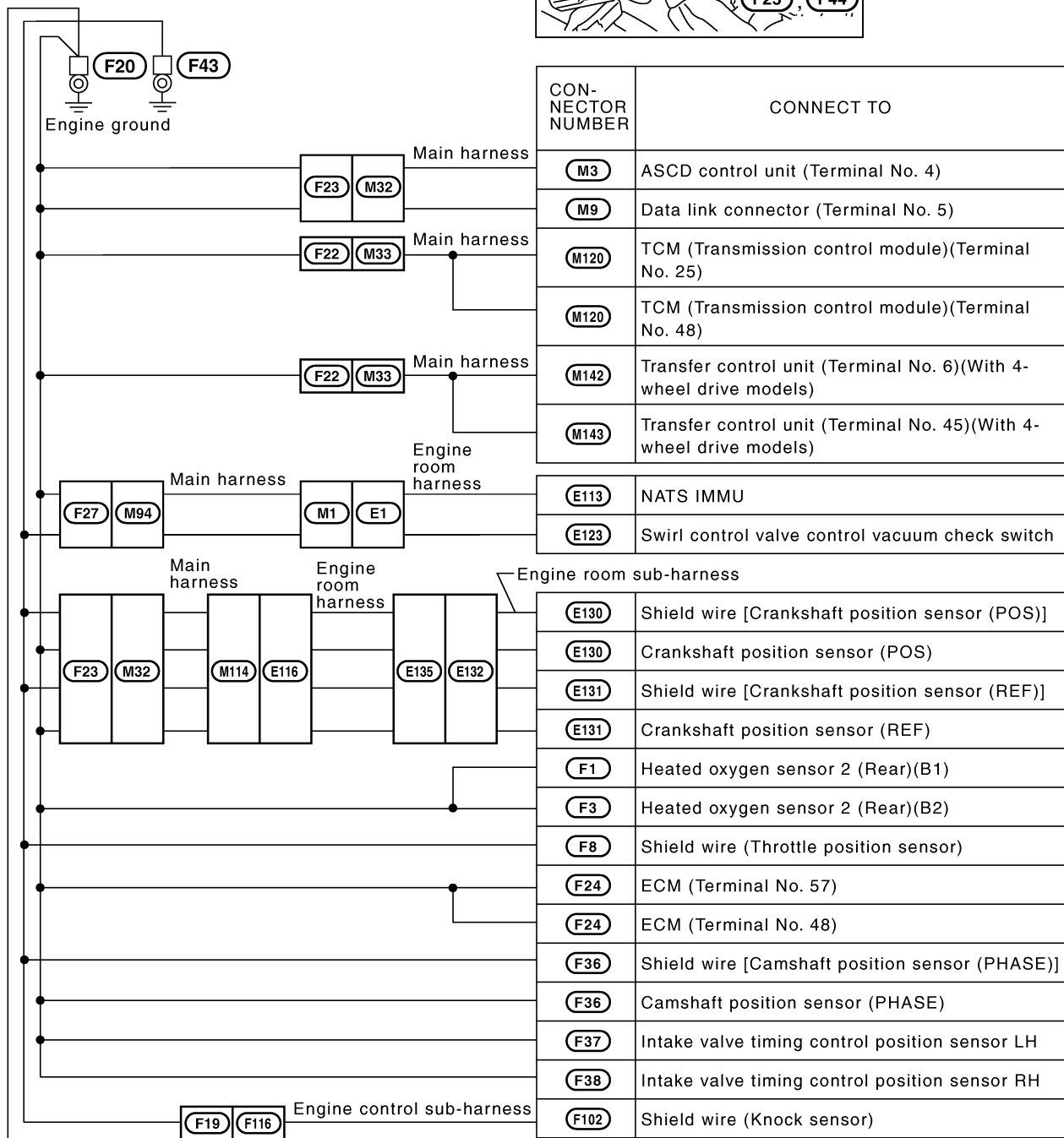
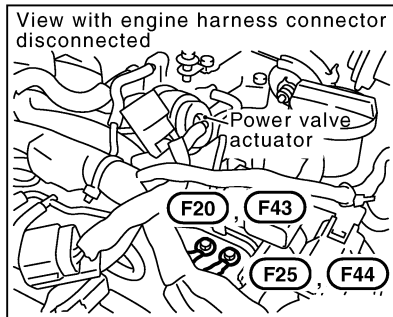

B Next page

MEL147M

GROUND

Ground Distribution (Cont'd)

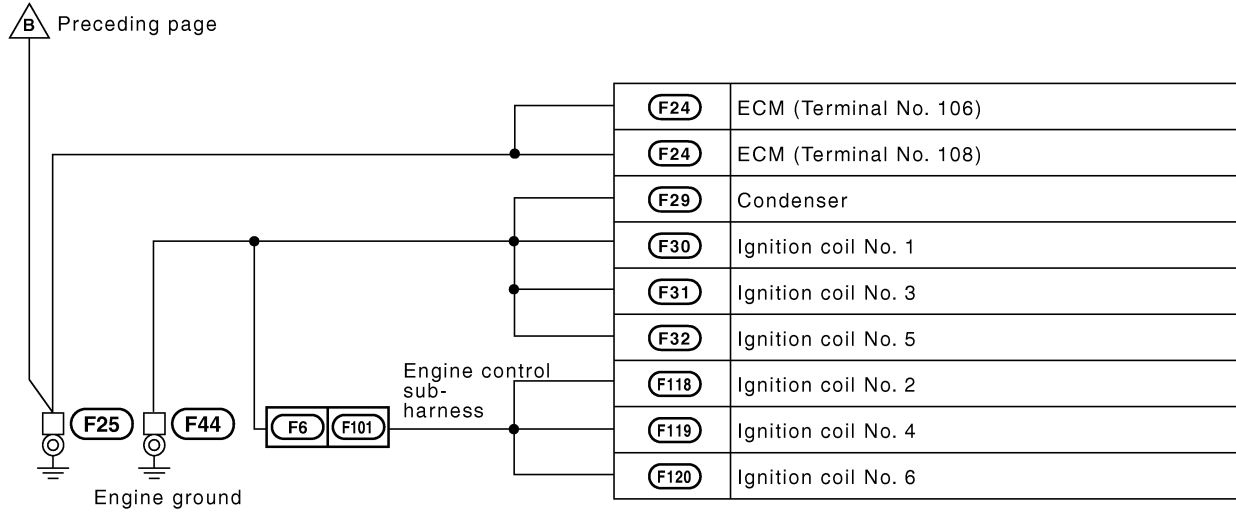

MEL233M

GI

MA

EM

LC

EC

FE

AT

TF

PD

AX

SU

BR

ST

RS

BT

HA

SC

EL

IDX

GROUND

Ground Distribution (Cont'd)

BODY HARNESS RH

NBEL0008S04

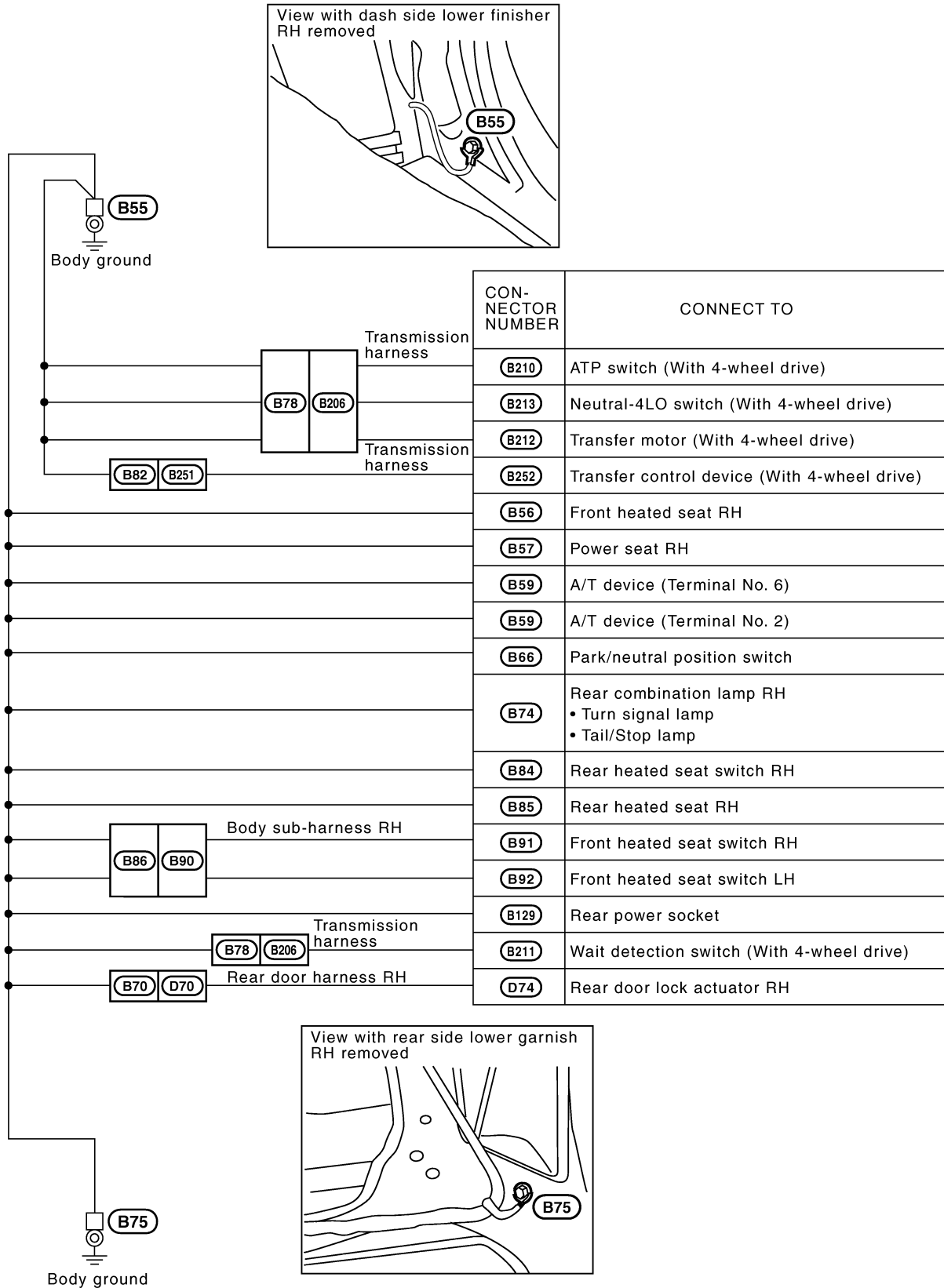

MEL148M

BODY HARNESS LH

NBEL0008S05

GI
MA
EM
LC
EC
FE
AT
TF
PD
AX
SU
BR
ST
RS
BT
HA
SC
EL
IDX

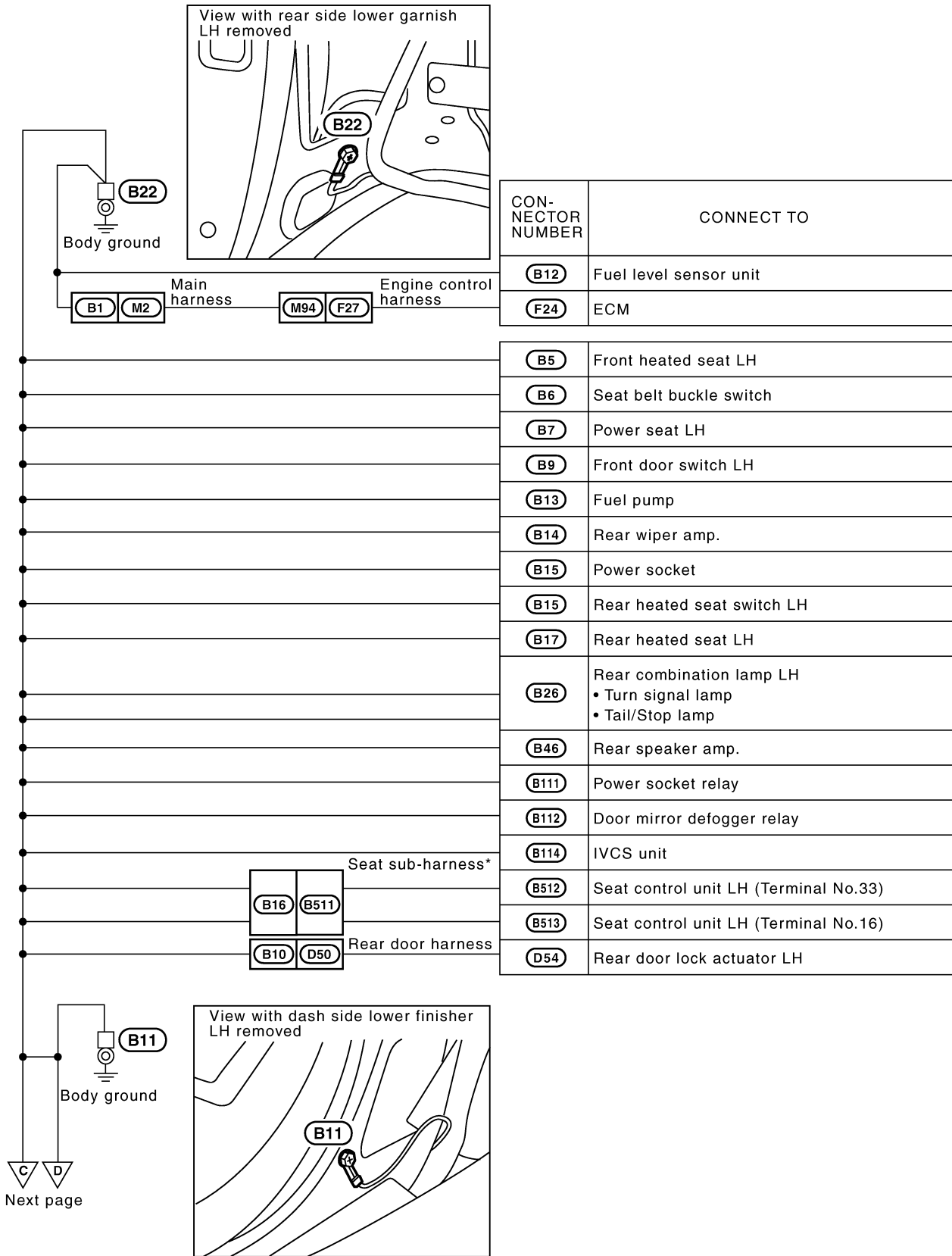

Next page

*: This sub-harness is not shown in "Harness Layout", EL section.

GROUND

Ground Distribution (Cont'd)

△ C △ D Preceding page

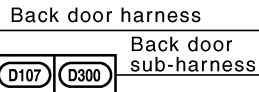
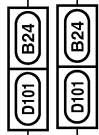

CON-NECTOR NUMBER	CONNECT TO
D103	Luggage room lamp
D302	High-mounted stop lamp

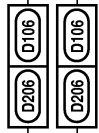

D201	Back door key cylinder switch
D202	License plate lamp LH • License plate lamp • Back-up lamp
D207	Back door lock actuator
D208	Back door switch
D209	Glass hatch switch
D211	License plate lamp RH • License plate lamp • Back-up lamp
D212	Rear wiper motor
D213	Back door handle switch

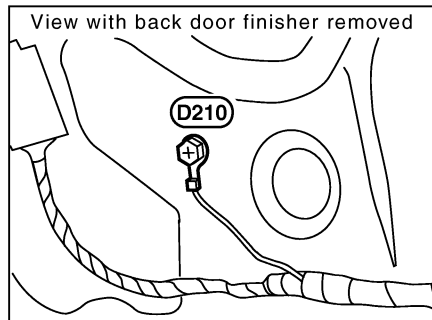

MEL150M

GROUND

Ground Distribution (Cont'd)

BODY HARNESS

NBEL0008S07

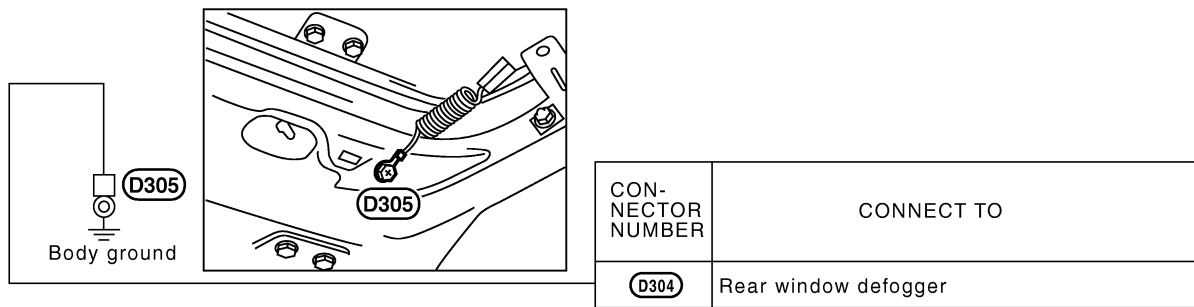
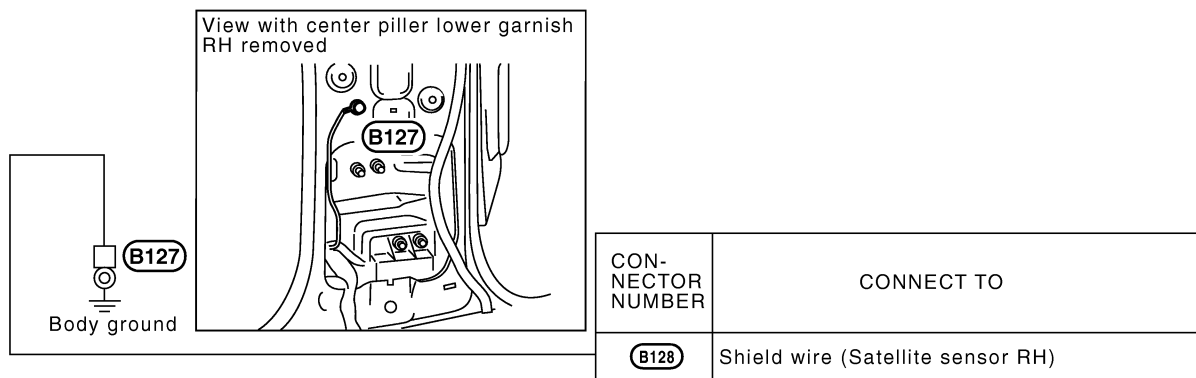
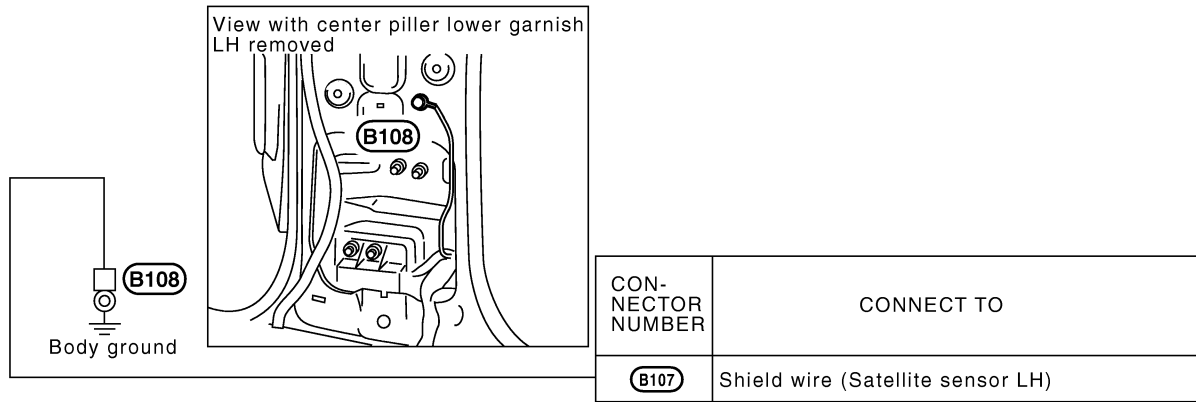

MEL151M

MEL152M

GI

MA

EM

LC

EC

FE

AT

TF

PD

AX

SU

BR

ST

RS

BT

HA

SC

EL

IDX

COMBINATION SWITCH

Check

Check

NBEL0009

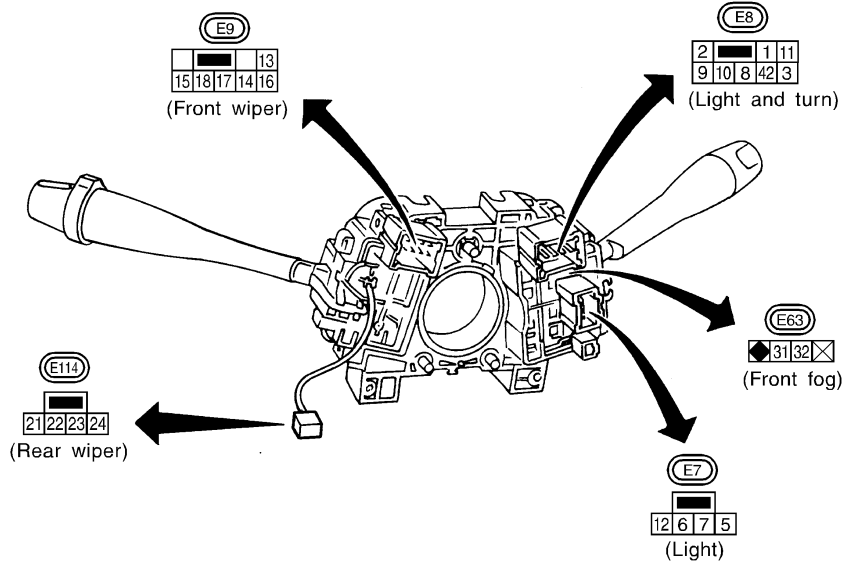
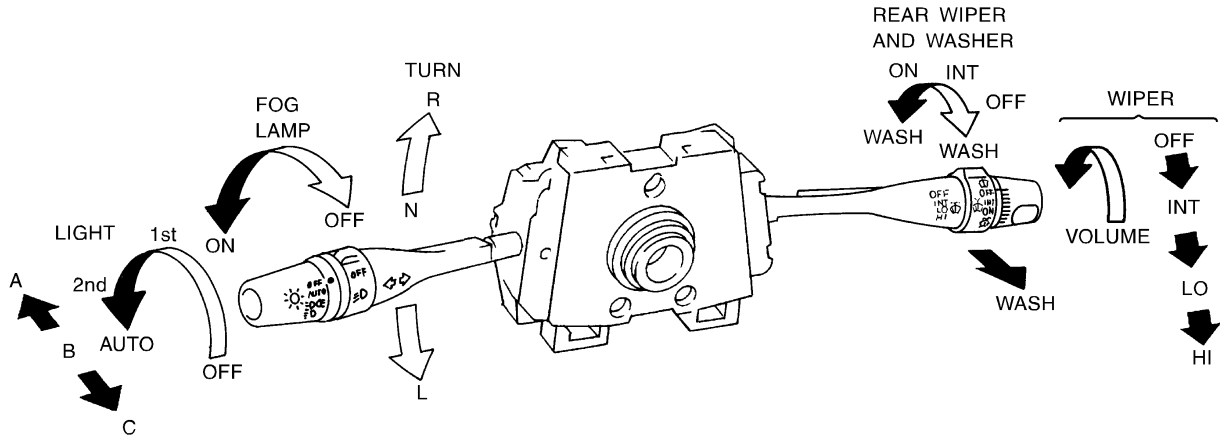

LIGHTING SWITCH

	OFF	AUTO	1ST	2ND
5			<input type="radio"/>	<input type="radio"/>
11			<input type="radio"/>	<input type="radio"/>
8				<input type="radio"/>
12				<input type="radio"/>
42		<input type="radio"/>		
(8)		<input type="radio"/>		

	A	B	C
(5)	<input type="radio"/>	<input type="radio"/>	<input type="radio"/>
7	<input type="radio"/>	<input type="radio"/>	<input type="radio"/>
6	<input type="radio"/>	<input type="radio"/>	<input type="radio"/>
(8)	<input type="radio"/>	<input type="radio"/>	<input type="radio"/>
10	<input type="radio"/>	<input type="radio"/>	<input type="radio"/>
9	<input type="radio"/>	<input type="radio"/>	<input type="radio"/>
(12)	<input type="radio"/>	<input type="radio"/>	<input type="radio"/>

FRONT WIPER AND WASHER SWITCH

	LO	AUTO STOP	AMP	WASH	HI	EARTH
OFF	<input type="radio"/>	<input type="radio"/>				
INT	<input type="radio"/>	<input type="radio"/>	<input type="radio"/>			
LO	<input type="radio"/>					
HI					<input type="radio"/>	
WASH				<input type="radio"/>		

VARIABLE INTERMITTENT WIPER VOLUME



FOG LAMP SWITCH

	OFF	ON
31	<input type="radio"/>	
32		<input type="radio"/>

TURN SIGNAL LAMP SWITCH

	L	N	R
1	<input type="radio"/>		<input type="radio"/>
2			<input type="radio"/>
3	<input type="radio"/>		

REAR WIPER SWITCH

	WASH	OFF	INT	ON	WASH
21			<input type="radio"/>		
22			<input type="radio"/>	<input type="radio"/>	
23	<input type="radio"/>				
24	<input type="radio"/>	<input type="radio"/>		<input type="radio"/>	

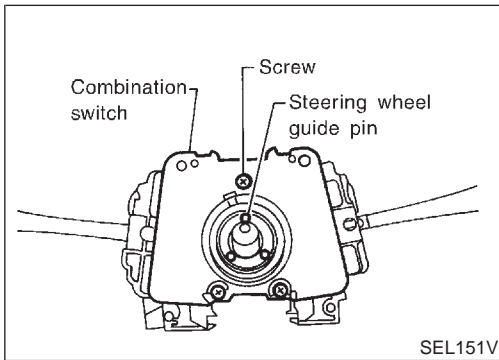
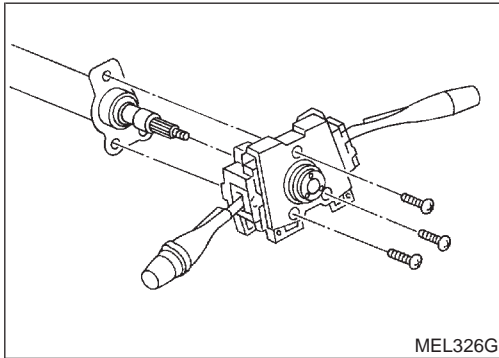
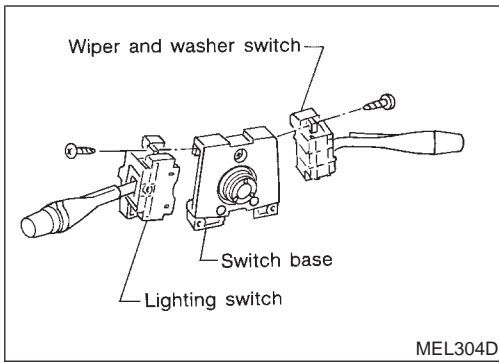

Replacement

For removal and installation of spiral cable, refer to ^{NBEL0010}RS-18, "Installation — Air Bag Module and Spiral Cable".

- Each switch can be replaced without removing combination switch base.
- To remove combination switch base, remove base attaching screw.
- Before installing the steering wheel, align the steering wheel guide pins with the screws which secure the combination switch as shown in the left figure.

GI

MA

EM

LC

EC

FE

AT

TF

PD

AX

SU

BR

ST

RS

BT

HA

SC

EL

IDX

STEERING SWITCH

Check

NBEL0011

Check

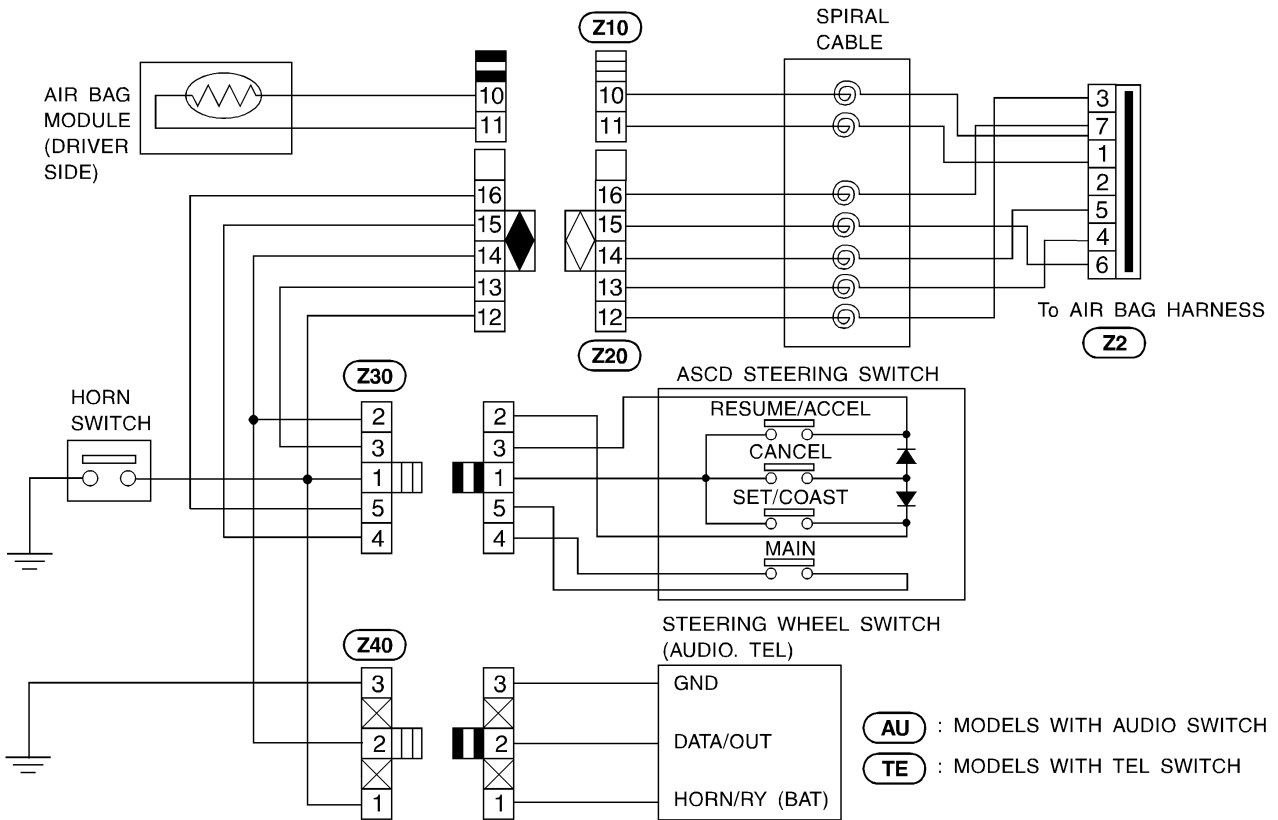
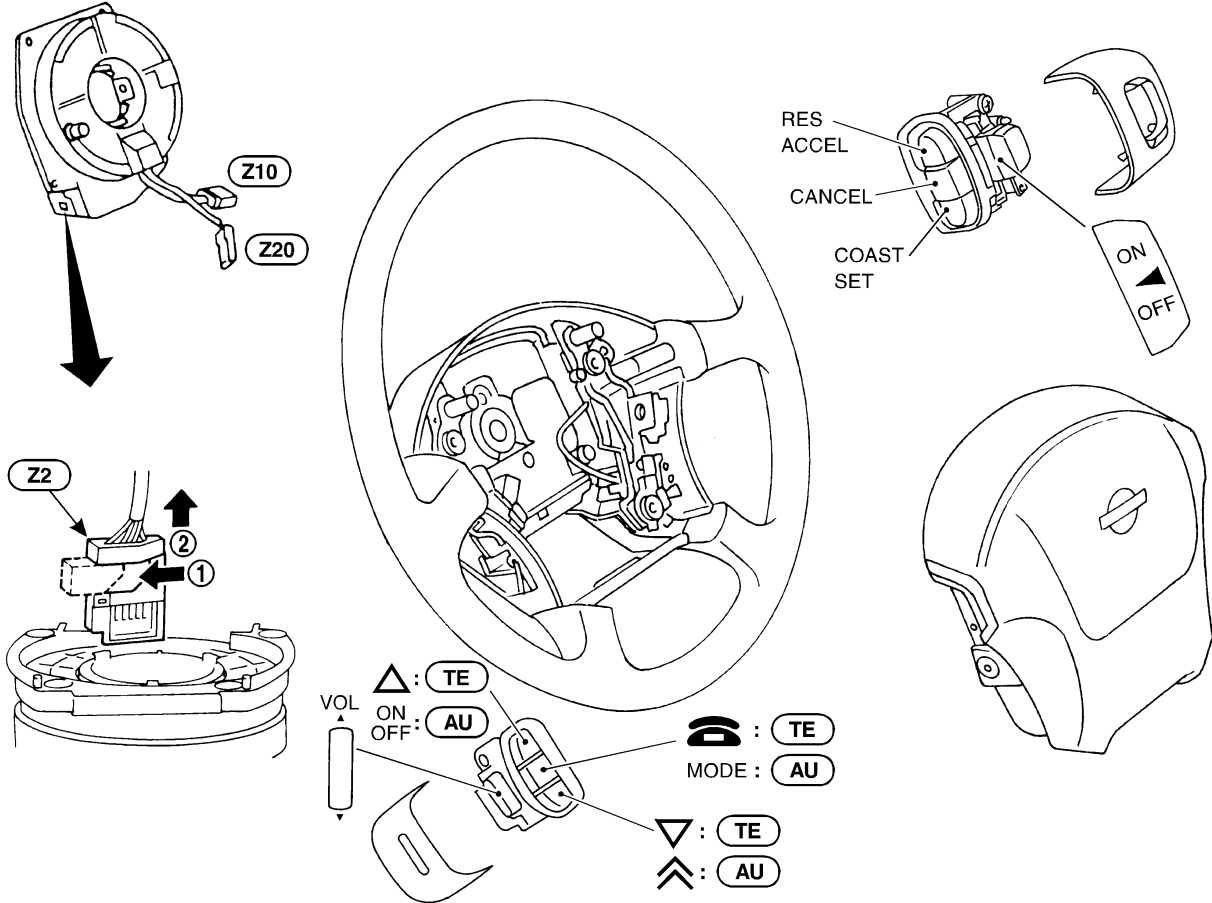

MEL133M

HEADLAMP (FOR USA) — XENON TYPE —

Component Parts and Harness Connector Location

Component Parts and Harness Connector Location

NBEL0159

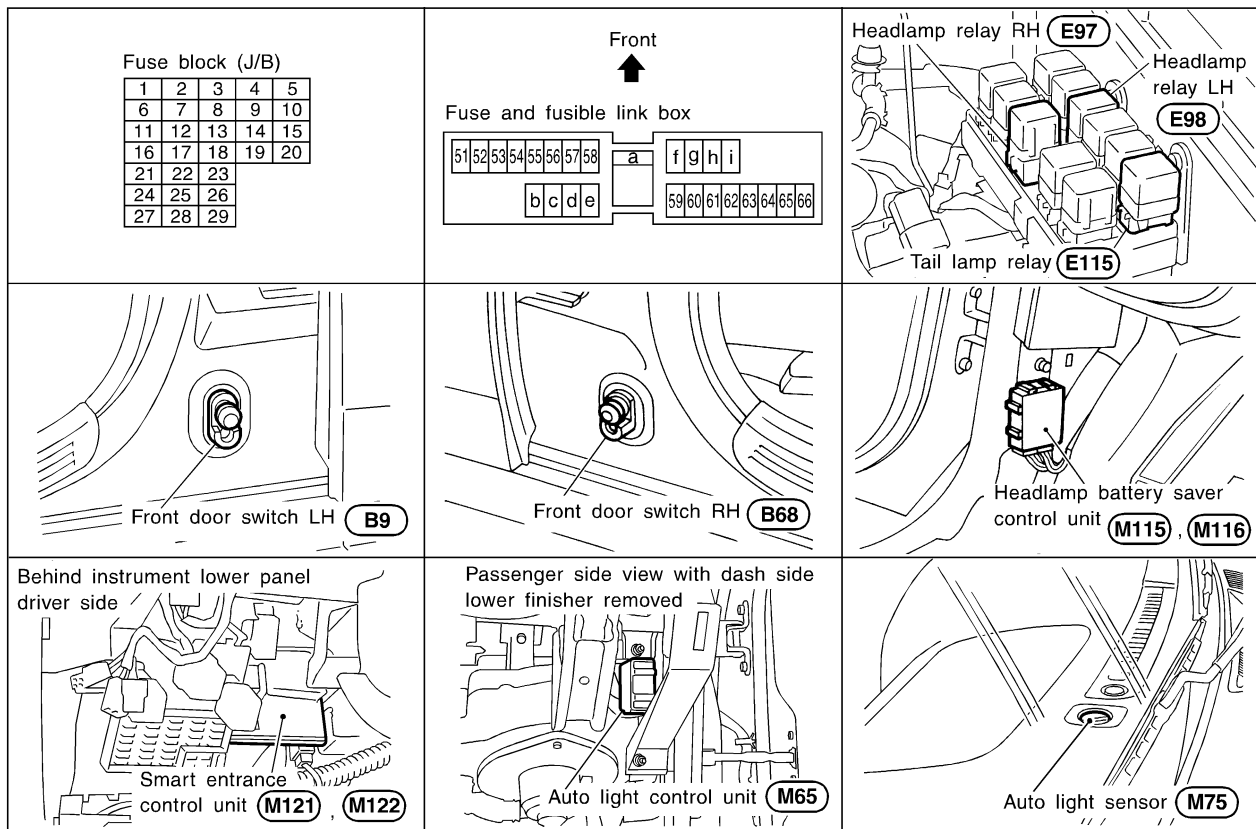

SEL460X

System Description

NBEL0188

The headlamp operation is controlled by the lighting switch which is built into the combination switch and headlamp battery saver control unit. And the headlamp battery saver system is controlled by the headlamp battery saver control unit and smart entrance control unit.

OUTLINE

NBEL0188S01

Power is supplied at all times

- to headlamp LH relay terminals 1 and 3
- through 15A fuse (No. 60, located in the fuse and fusible link box), and
- to headlamp LH relay terminal 6
- through 20A fuse (No. 32, located in the fuse and fusible link box), and
- to headlamp RH relay terminals 1 and 3
- through 15A fuse (No. 59, located in the fuse and fusible link box), and
- to headlamp RH relay terminal 6
- through 20A fuse (No. 31, located in the fuse and fusible link box), and
- to headlamp battery saver control unit terminal 7, and
- to smart entrance control unit terminal 10
- through 7.5A fuse [No. 24, located in the fuse block (J/B)].

When the ignition switch is in the ON or START position, power is supplied

- to headlamp battery saver control unit terminal 1
- through 10A fuse [No. 16, located in the fuse block (J/B)], and
- to headlamp battery saver control unit terminal 10,
- to auto light control unit terminal 1 and
- to smart entrance control unit terminal 33
- through 7.5A fuse [No. 11, located in the fuse block (J/B)].

GI
MA
EM
LC
EC
FE
AT
TF
PD
AX
SU
BR
ST
RS
BT
HA
SC
EL
IDX

HEADLAMP (FOR USA) — XENON TYPE —

System Description (Cont'd)

When the ignition switch is in the ACC or ON position, power is supplied

- to auto light control unit terminal 2
- through 10A fuse [No. 9, located in the fuse block (J/B)]

Ground is supplied

- to headlamp battery saver control unit terminals 4 and 11
- through body grounds M77 and M111, and M4, M66 and M147
- to auto light control unit terminal 5
- through body grounds M4, M66 and M147.

Power Supply to Low Beam and High Beam

NBEL0188S0101

When lighting switch is in 2ND or PASS position, ground is supplied

- to headlamp relay (LH and RH) terminal 2 from headlamp battery saver control unit terminals 2 and 8
- through headlamp battery saver control unit terminals 3 and 9,
- from lighting switch terminal 12.

Headlamp relays (LH and RH) are energized and then power is supplied to headlamps (LH and RH).

LOW BEAM OPERATION

NBEL0188S02

When the lighting switch is turned to the 2ND position and placed in LOW ("B") position, power is supplied

- from terminal 7 of each headlamp relay
- to terminal 3 of each headlamp

Ground is supplied

- to terminal 4 of each headlamp
- through body grounds E13 and E41.

With power and ground supplied, the headlamp(s) will illuminate.

HIGH BEAM OPERATION/FLASH-TO-PASS OPERATION

NBEL0188S03

When the lighting switch is turned to the 2ND position and placed in HIGH ("A") position or PASS ("C") position, power is supplied

- from terminal 5 of headlamp LH relay
- to terminal 1 of headlamp LH, and
- to combination meter terminal 26 for the HIGH BEAM indicator
- from terminal 5 of headlamp RH relay
- to terminal 1 of headlamp RH.

Ground is supplied

- to headlamp LH terminal 2
- to combination meter terminal 27 for the HIGH BEAM indicator
- through lighting switch terminals 6 and 5
- through body grounds E13 and E41, and
- to headlamp RH terminal 2
- through lighting switch terminals 9 and 8
- through body grounds E13 and E41.

With power and ground supplied, the high beams and the high beam indicator illuminate.

BATTERY SAVER CONTROL

NBEL0188S04

When the ignition switch is turned from ON (or START) to OFF (or ACC) positions while headlamps illuminate, the RAP signal is supplied to terminal 10 of the headlamp battery saver control unit from smart entrance control unit terminal 5.

After counting 45 seconds by the RAP signal from the smart entrance control unit to headlamp battery saver control unit, the ground supply to terminal 2 of the headlamp LH and RH relay from headlamp battery saver control unit terminals 2 and 8 is terminated.

Then the headlamps are turned off.

The headlamps are turned off when driver or passenger side door is opened even if 45 seconds have not passed after ignition switch is turned from ON (or START) to OFF (or ACC) positions while headlamps are illuminated.

When the lighting switch is turned from OFF to 2ND after headlamps are turned to off by the battery saver control, ground is supplied

HEADLAMP (FOR USA) — XENON TYPE —

System Description (Cont'd)

- to headlamp battery saver control unit terminals 5 and 13 from lighting switch terminal 11, and
- to headlamp LH and RH relays terminal 2 from headlamp battery saver control unit terminals 2 and 8
- through headlamp battery saver control unit terminals 3 and 9, and
- through lighting switch terminal 12.

GI

Then headlamps illuminate again.

MA

AUTO LIGHT OPERATION

NBEL0188S05

When lighting switch is in "AUTO" position, ground is supplied

- to auto light control unit terminal 10
- from lighting switch terminal 42.

EM

When ignition switch is turn to "ON" or "START" position and outside brightness is darker than prescribed level. Ground is supplied

LC

- to headlamp relay LH and RH terminals 2
- through battery saver control unit
- from auto light control unit terminal 6, and
- to tail lamp relay terminal 1
- through battery saver control unit
- from auto light control unit terminal 7.

EC

FE

AT

Then both headlamp relays and tail lamp relay are energized, headlamps (low or high) and tail lamps are illuminate according to switch position.

Auto light operation allows headlamps and tail lamps to go off when

TF

- Ignition switch is turned to "OFF" position or
- Outside brightness is brighter than prescribed level.

PD

NOTE:

The delay time is varies up to maximum of 20 seconds as the outside brightness changes.

For parking, license and tail lamp auto operation, refer to "PARKING, LICENSE AND TAIL LAMPS".

AX

THEFT WARNING SYSTEM

NBEL0188S06

The theft warning system will flash the low beams if the system is triggered. Refer to "THEFT WARNING SYSTEM" (EL-296).

SU

BR

ST

RS

BT

HA

SC

EL

IDX

HEADLAMP (FOR USA) — XENON TYPE —

System Description (Cont'd)

XENON HEADLAMP

=NBEL0188S07

Xenon type headlamp is adopted to the low beam headlamps. Xenon bulbs do not use a filament. Instead, they produce light when a high voltage current is passed between two tungsten electrodes through a mixture of xenon (an inert gas) and certain other metal halides. In addition to added lighting power, electronic control of the power supply gives the headlamps stable quality and tone color.

Following are some of the many advantage of the xenon type headlamp.

- The light produced by the headlamps is white color approximating sunlight that is easy on the eyes.
- Light output is nearly double that of halogen headlamps, affording increased area of illumination.
- The light features a high relative spectral distribution at wavelengths to the human eye is most sensitive, which means that even in the rain, more light is reflected back from the road surface toward the vehicle, for added visibility.
- Power consumption is approximately 25 percent less than halogen headlamps, reducing battery load.

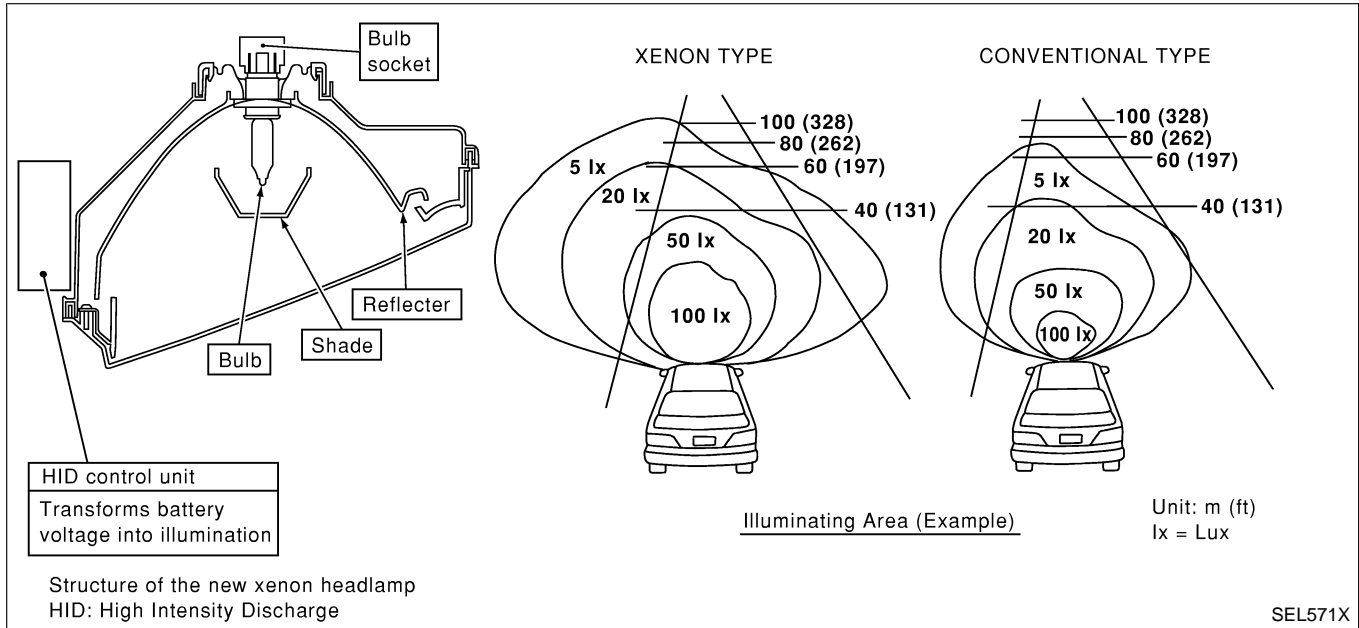

HEADLAMP (FOR USA) — XENON TYPE —

Schematic

NBEL0160

Schematic

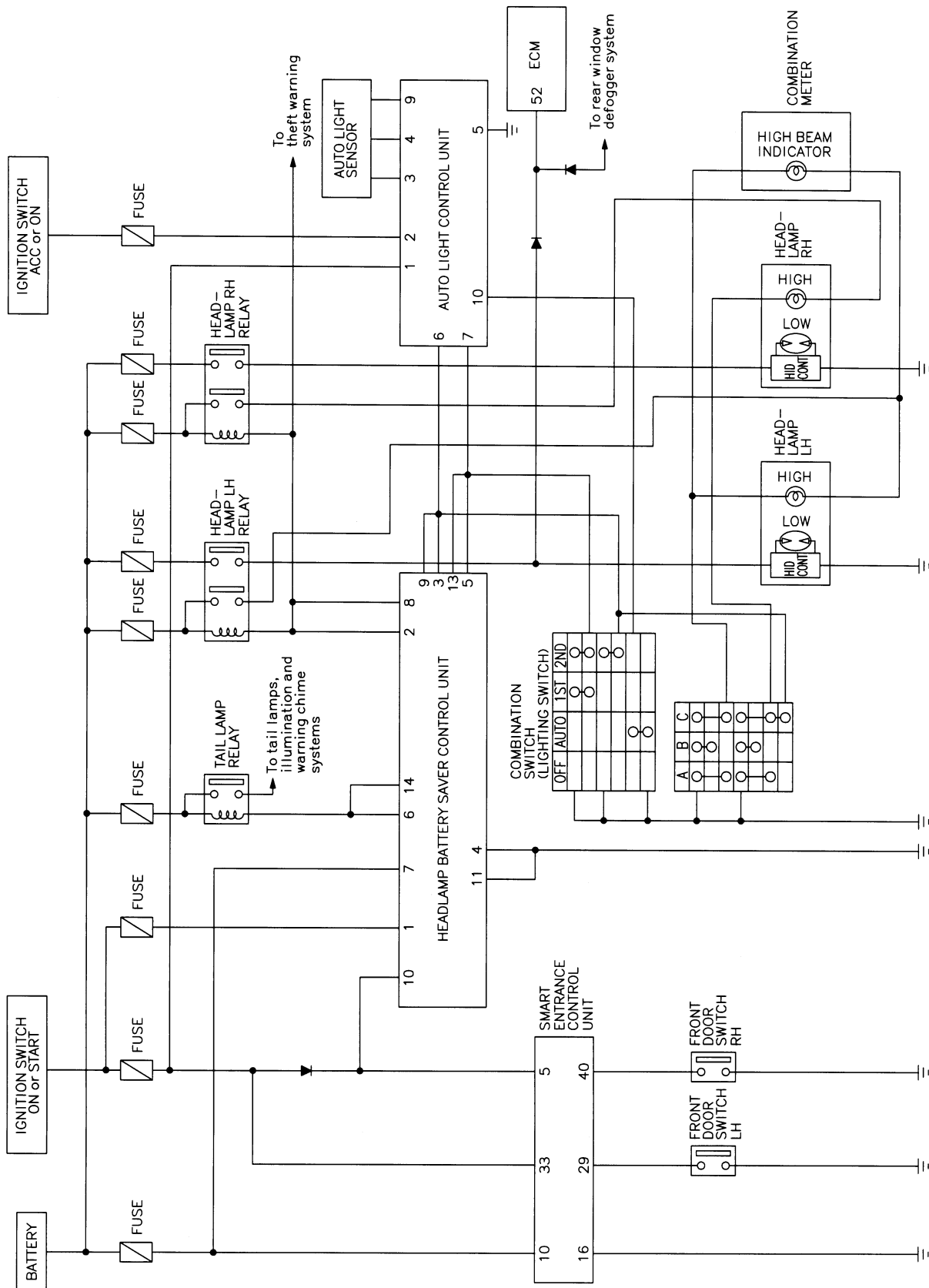

GI
MA
EM
LC
EC
FE
AT
TF
PD
AX
SU
BR
ST
RS
BT
HA
SC
EL
IDX

MEL761L

HEADLAMP (FOR USA) — XENON TYPE —

Wiring Diagram — H/LAMP —

Wiring Diagram — H/LAMP —

NBEL0013

EL-H/LAMP-01

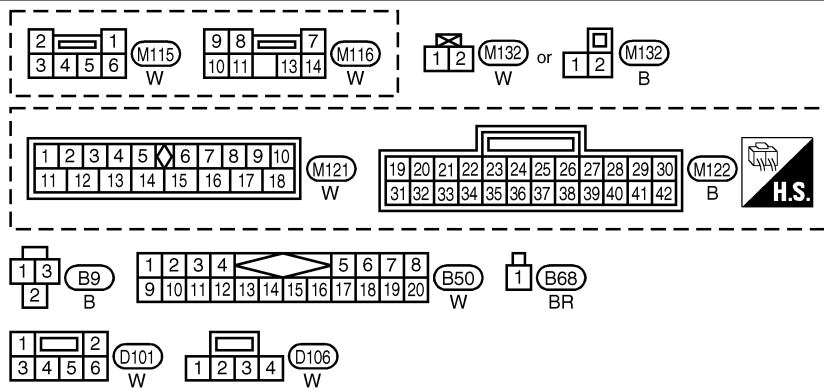
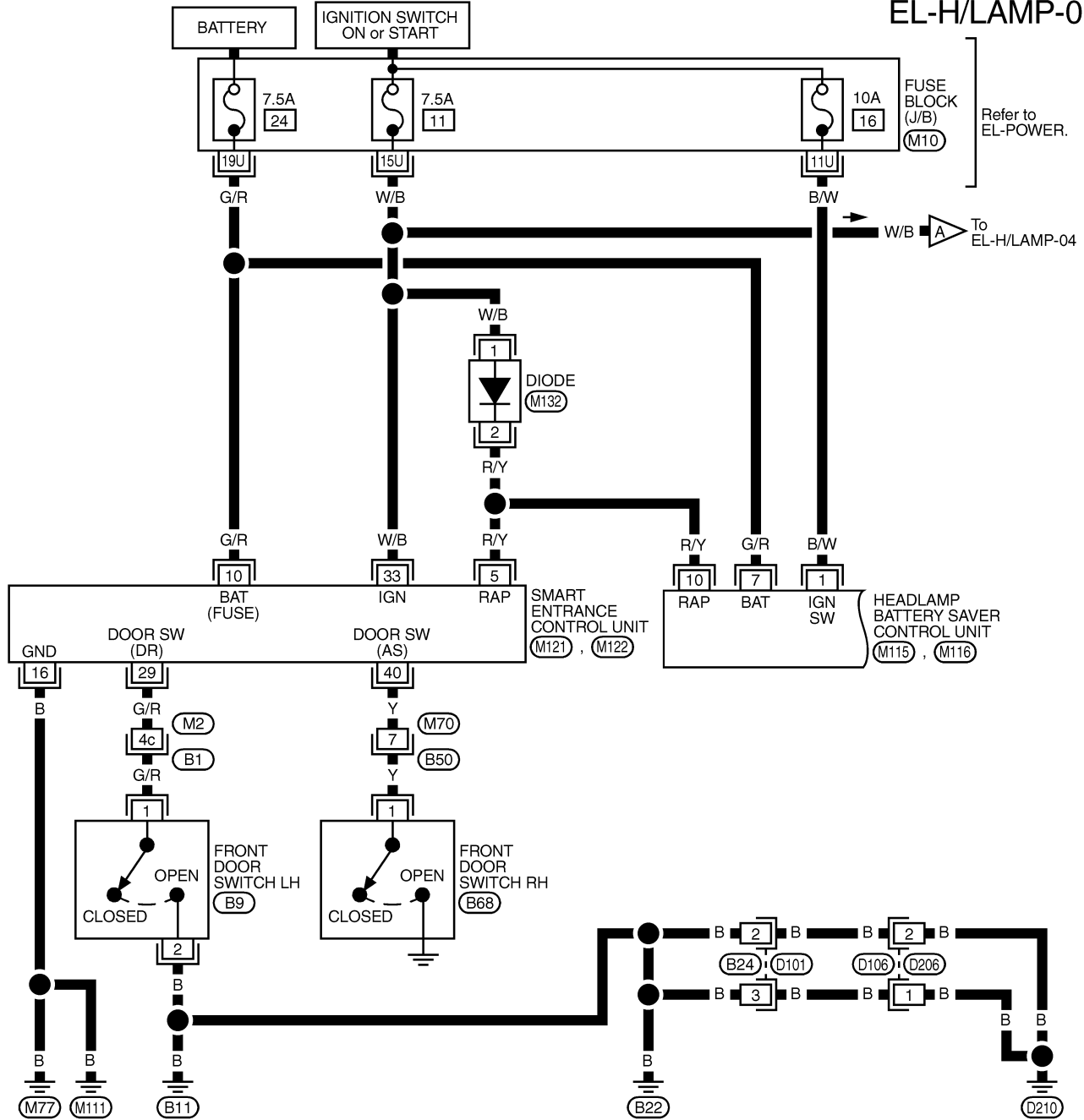

REFER TO THE FOLLOWING.

(B1) -SUPER
MULTIPLE JUNCTION (SMJ)

(M10) -FUSE BLOCK-
JUNCTION BOX (J/B)

MEL0010

HEADLAMP (FOR USA) — XENON TYPE —

Wiring Diagram — H/LAMP — (Cont'd)

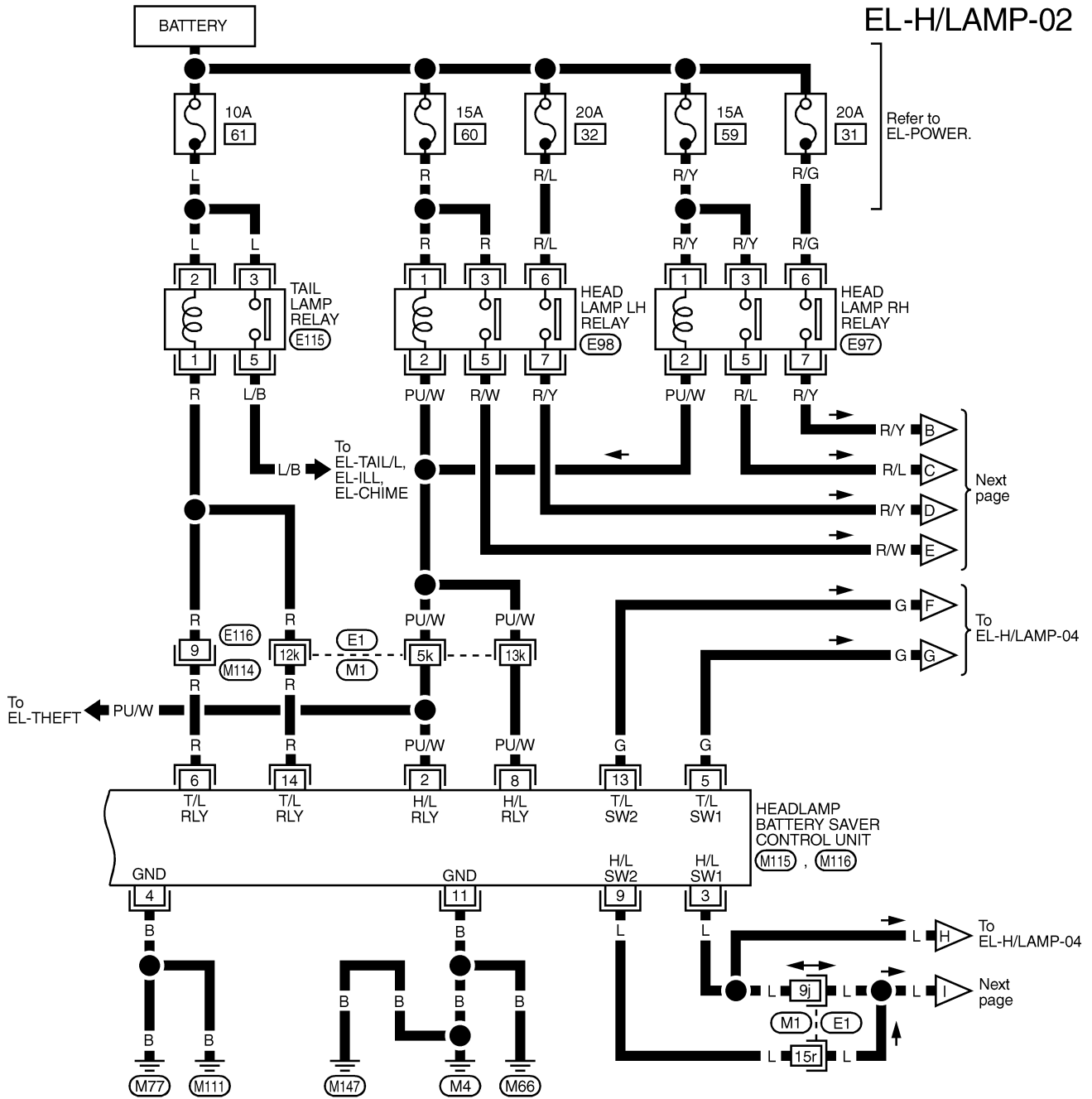

GI
MA
EM
LC
EC
FE
AT
TF
PD
AX
SU
BR
ST
RS
BT
HA
SC
EL
IDX

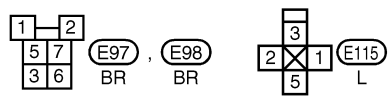
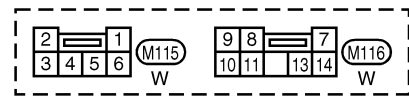
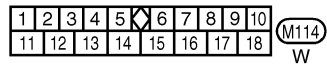

REFER TO THE FOLLOWING.
 (E1) -SUPER
 MULTIPLE JUNCTION (SMJ)

MEL763L

HEADLAMP (FOR USA) — XENON TYPE —

Wiring Diagram — H/LAMP — (Cont'd)

EL-H/LAMP-03

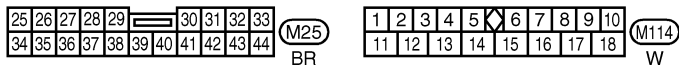
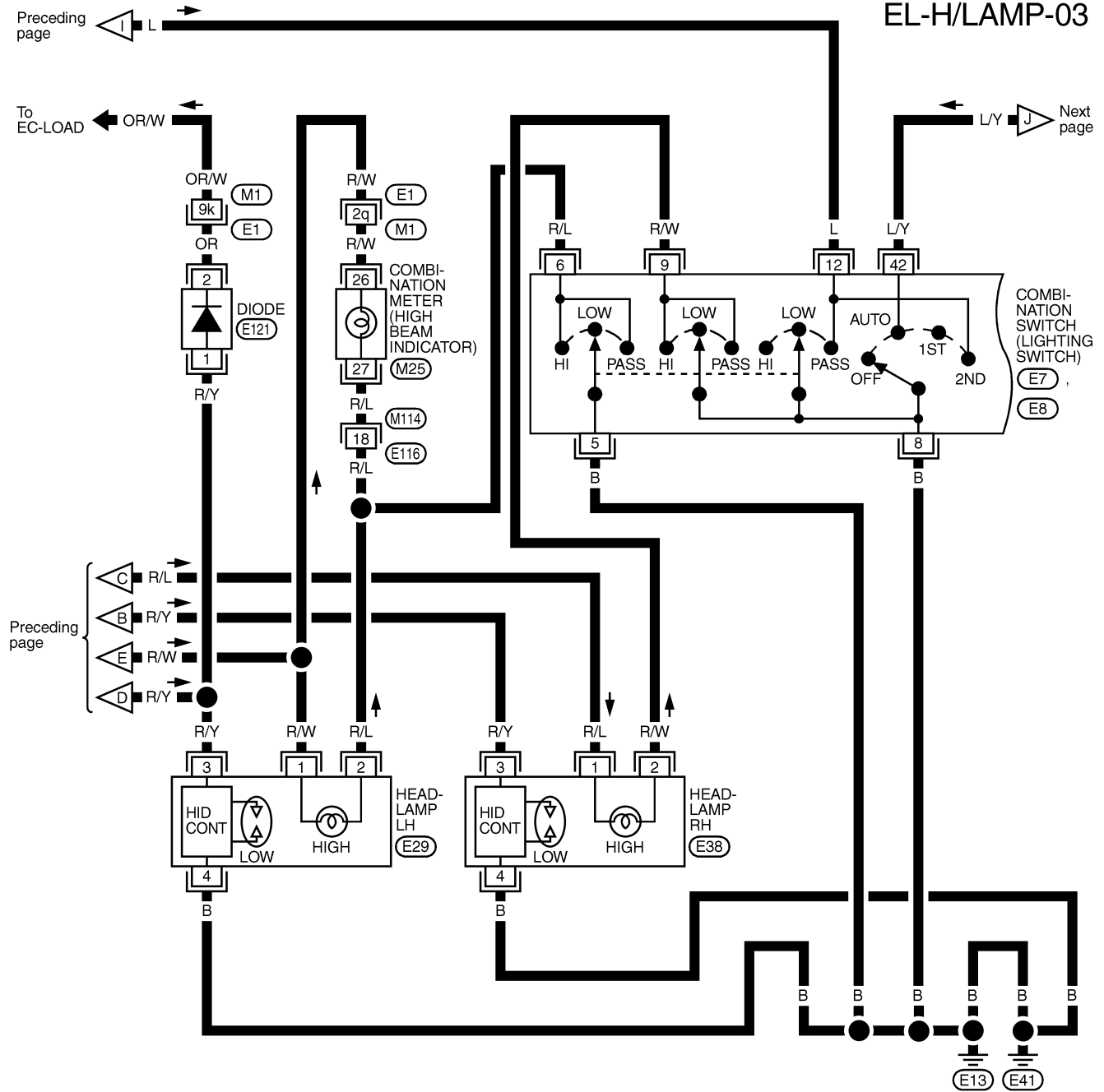

REFER TO THE FOLLOWING.
 (E1) - SUPER
 MULTIPLE JUNCTION (SMJ)

MEL764L

HEADLAMP (FOR USA) — XENON TYPE —

Wiring Diagram — H/LAMP — (Cont'd)

EL-H/LAMP-04

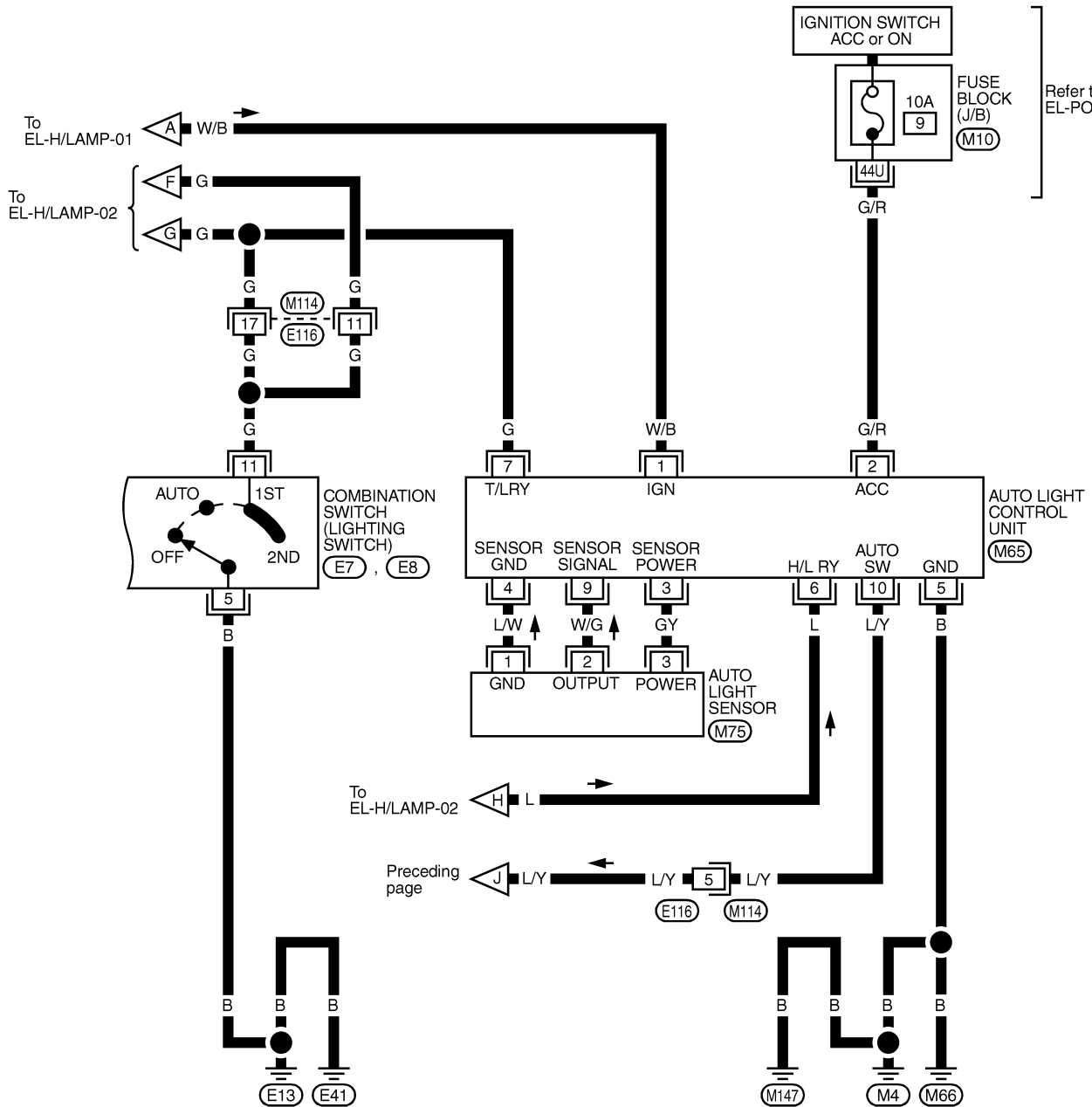

GI
MA
EM
LC
EC
FE
AT
TF
PD
AX
SU
BR
ST
RS
BT
HA
SC
EL
IDX

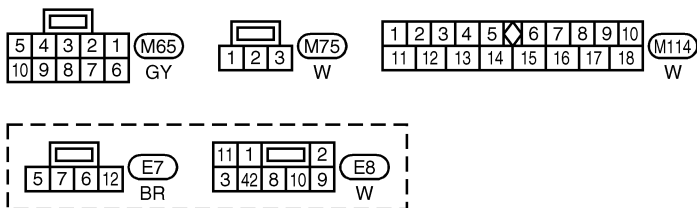

REFER TO THE FOLLOWING.
 (M10) - FUSE BLOCK-
 JUNCTION BOX (J/B)

MEL765L

HEADLAMP (FOR USA) — XENON TYPE —

Trouble Diagnoses

WARNING:

- The xenon headlamp has a high-tension current generating area. Be extremely careful when removing and installing. Be certain to disconnect the battery negative cable prior to removing or installing.
- When the xenon headlamp is lit, do not touch the harness (covered with red or amber insulation), bulb itself or the bulb socket with your bare hands.
- Never service a xenon headlamp with wet hands.
- When checking body side harness with a circuit tester, be certain to disconnect the harness connector from the xenon headlamp.
- When the xenon headlamp is lit, the xenon bulb must be installed in the headlamp housing. (Never turn on xenon headlamp, if the bulb is out of the headlamp housing.)

CAUTION:

Make sure to install the bulb securely; if the xenon bulb is improperly installed in its socket, high-tension current leaks occur. This may lead to a melted bulb and/or bulb socket.

Symptom	Possible cause	Repair order
Neither headlamp operates.	<ol style="list-style-type: none"> 1. 7.5A fuse 2. Headlamp relay circuit 3. Lighting switch 4. Lighting switch ground circuit 5. Headlamp battery saver control unit 	<ol style="list-style-type: none"> 1. Check 7.5A fuse [No. 24, located in fuse block (J/B)]. Verify battery positive voltage is present at terminal 7 of headlamp battery saver control unit. 2. Check between battery saver control unit and headlamp relays (LH and RH). 3. Check Lighting switch. 4. Check harness between lighting switch terminal 8 and ground. 5. Check headlamp battery saver control unit.
Headlamp LH (low and high beam) does not operate, but headlamp RH (low and high beam) does operate.	<ol style="list-style-type: none"> 1. 15A fuse 2. Headlamp LH relay 3. Headlamp LH relay circuit 	<ol style="list-style-type: none"> 1. Check 15A fuse (No. 60, located in fusible link and fuse box). Verify battery positive voltage is present at terminals 1 and 3 of headlamp LH relay. 2. Check headlamp LH relay. 3. Check harness between headlamp LH relay and headlamp battery saver control unit.
Headlamp RH (low and high beam) does not operate, but headlamp LH (low and high beam) does operate.	<ol style="list-style-type: none"> 1. 15A fuse 2. Headlamp RH relay 3. Headlamp RH relay circuit 	<ol style="list-style-type: none"> 1. Check 15A fuse (No. 59, located in fusible link and fuse box). Verify battery positive voltage is present at terminals 1 and 3 of headlamp RH relay. 2. Check headlamp RH relay. 3. Check harness between headlamp RH relay and headlamp battery saver control unit.
LH high beam does not operate, but LH low beam operates.	<ol style="list-style-type: none"> 1. Bulb 2. Headlamp LH relay 3. Open in the LH high beams circuit 4. Lighting switch 5. Lighting switch ground circuit 	<ol style="list-style-type: none"> 1. Check bulb. 2. Check headlamp LH relay. 3. Check the following. <ol style="list-style-type: none"> a. Harness between headlamp LH relay terminal 5 and headlamp LH for open circuit. b. Harness between headlamp LH and lighting switch for open circuit. 4. Check lighting switch. 5. Check harness between lighting switch and ground.

HEADLAMP (FOR USA) — XENON TYPE —

Trouble Diagnoses (Cont'd)

Symptom	Possible cause	Repair order	
LH low beam does not operate, but LH high beam operates.	<ol style="list-style-type: none"> 1. 20A fuse 2. Headlamp LH relay 3. Open in the LH low beam circuit 4. LH low beam ground circuit 5. Xenon bulb 6. HID control unit 7. Booster 	<ol style="list-style-type: none"> 1. Check 20A fuse (No. 32, located in fusible link and fuse box). Verify battery positive voltage is present at terminal 6 of headlamp LH relay. 2. Check headlamp LH relay 3. Check harness between headlamp LH relay terminal 7 and headlamp LH for open circuit. 4. Check harness between headlamp LH and ground. 5. Replace the xenon bulb with other side bulb or new one. (If headlamps illuminate correctly, replace the bulb.) 6. Replace the HID control unit with other side control unit or new one. (If headlamps illuminate correctly, replace the control unit.) 7. Replace booster as a headlamp assembly. 	<p>GI</p> <p>MA</p> <p>EM</p> <p>LC</p> <p>EC</p>
RH high beam does not operate, but RH low beam operates.	<ol style="list-style-type: none"> 1. Bulb 2. Headlamp RH relay 3. Open in the RH high beams circuit 4. Lighting switch 	<ol style="list-style-type: none"> 1. Check bulb. 2. Check headlamp RH relay. 3. Check the following. <ol style="list-style-type: none"> a. Harness between headlamp RH relay terminal 5 and headlamp RH for open circuit b. Harness between headlamp RH and lighting switch for open circuit 4. Check lighting switch. 	<p>FE</p> <p>AT</p> <p>TF</p>
RH low beam does not operate, but RH high beam operates.	<ol style="list-style-type: none"> 1. 20A fuse 2. Headlamp RH relay 3. Open in the RH low beam circuit 4. RH low beam ground circuit 5. Xenon bulb 6. HID control unit 7. Booster 	<ol style="list-style-type: none"> 1. Check 20A fuse (No. 31 located in fusible link and fuse box). Verify battery positive voltage is present at terminal 6 of headlamp RH relay. 2. Check headlamp RH relay 3. Check harness between headlamp RH relay terminal 7 and headlamp RH for open circuit. 4. Check harness between headlamp RH and ground. 5. Replace the xenon bulb with other side bulb or new one. (If headlamps illuminate correctly, replace the bulb.) 6. Replace the HID control unit with other side control unit or new one. (If headlamps illuminate correctly, replace the control unit.) 7. Replace booster as a headlamp assembly. 	<p>PD</p> <p>AX</p> <p>SU</p> <p>BR</p>
High beam indicator does not work.	<ol style="list-style-type: none"> 1. Bulb 2. Open in high beam circuit 	<ol style="list-style-type: none"> 1. Check bulb in combination meter. 2. Check the following. <ol style="list-style-type: none"> a. Harness between headlamp LH relay and combination meter for an open circuit b. Harness between high beam indicator and lighting switch 	<p>ST</p> <p>RS</p>
Battery saver control does not operate properly.	<ol style="list-style-type: none"> 1. RAP signal circuit 2. Door switch LH or RH circuit 3. Lighting switch circuit 4. Headlamp battery saver control unit 5. Smart entrance control unit 	<ol style="list-style-type: none"> 1. Check harness between headlamp battery saver control unit terminal 10 and smart entrance control unit terminal 5 for open or short circuit. 2. Check the following. <ol style="list-style-type: none"> a. Harness between smart entrance control unit and LH or RH door switch for open or short circuit. b. LH or RH door switch ground circuit. c. LH or RH door switch. 3. Check the following. <ol style="list-style-type: none"> a. Harness between headlamp battery saver control unit terminals 5 or 13 and lighting switch terminal 11 for open or short circuit. b. Harness between lighting switch terminal 5 and ground. c. Lighting switch. 4. Check headlamp battery saver control unit. 5. Check smart entrance control unit. (EL-324) 	<p>BT</p> <p>HA</p> <p>SC</p> <p style="background-color: black; color: white; padding: 2px;">EL</p> <p>IDX</p>

HEADLAMP (FOR USA) — XENON TYPE —

Trouble Diagnoses (Cont'd)

BATTERY SAVER CONTROL UNIT INSPECTION TABLE

NBEL0189S01

Terminal No.	Wire color	Item	Condition			Voltage (Approximate value)
1	B/W	Ignition ON power supply	Ignition switch	OFF or ACC		Less than 1V
				ON or START		Battery voltage
2	PU/W	Headlamp relays (LH and RH)	Ignition switch (with lighting switch except OFF or 1ST)	OFF or ACC	More than 45 seconds after ignition switch is turned OFF or ACC	Battery voltage
					Within 45 seconds after ignition switch is turned OFF or ACC	Less than 1V
				ON or START		Less than 1V
			Headlamps illuminate by auto light control.			
3	L	Headlamp switch	Ignition switch ON	Lighting switch	Except PASS or 2ND	Battery voltage
					PASS or 2ND	Less than 1V
			Headlamps illuminate by auto light control.			
4	B	Ground	—			—
5	G	Tail lamp switch	Lighting switch	OFF		Battery voltage
				1ST or 2ND		Less than 1V
6	R	Tail lamp relay	Ignition switch (with lighting switch 1ST or 2ND)	OFF or ACC	More than 45 seconds after ignition switch is turned OFF or ACC	Battery voltage
					Within 45 seconds after ignition switch is turned OFF or ACC	Less than 1V
				ON or START		Less than 1V
			Headlamps illuminate by auto light control.			
7	G/R	Power supply	—			Battery voltage
8	PU/W	Headlamp relays (LH and RH)	Ignition switch (with lighting switch except OFF or 1ST)	OFF or ACC	More than 45 seconds after ignition switch is turned OFF or ACC	Battery voltage
					Within 45 seconds after ignition switch is turned OFF or ACC	Less than 1V
				ON or START		Less than 1V
			Headlamps illuminate by auto light control.			
9	L	Headlamp switch	Ignition switch ON	Lighting switch	Except PASS or 2ND	Battery voltage
					PASS or 2ND	Less than 1V
			Headlamps illuminate by auto light control.			

HEADLAMP (FOR USA) — XENON TYPE —

Trouble Diagnoses (Cont'd)

Terminal No.	Wire color	Item	Condition		Voltage (Approximate value)
10	R/Y	RAP signal	Ignition switch	OFF or ACC (After more than 45 seconds with ignition switch turned OFF or ACC)	Less than 1V
				ON or START	Battery voltage
11	B	Ground	—		—
13	G	Tail lamp switch	Lighting switch	OFF	Battery voltage
				1ST or 2ND	Less than 1V
14	R	Tail lamp relay	Ignition switch (with lighting switch 1ST or 2ND)	OFF or ACC	More than 45 seconds after ignition switch is turned OFF or ACC
					Within 45 seconds after ignition switch is turned OFF or ACC
				ON or START	Less than 1V
Headlamps illuminate by auto light control.					Less than 1V

Bulb Replacement/Xenon Type

NBEL0190

CAUTION:

- After replacing a new xenon bulb, be sure to make aiming adjustments.
 - Hold only the plastic base when handling the bulb. Never touch the glass envelope.
 - Do not leave headlamp reflector without bulb for a long period of time. Dust, moisture, smoke, etc. entering headlamp body may affect the performance of the headlamp. Remove headlamp bulb from the headlamp reflector just before a replacement bulb is installed.
1. Disconnect negative battery cable.
 2. Disconnect headlamp connector.
 3. Remove headlamp assembly.

WARNING:

Never service a xenon headlamp without disconnecting negative battery cable and with wet hands.

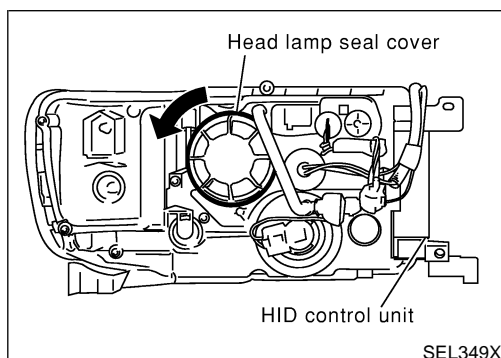

XENON BULB (LOW BEAM)

NBEL0190S01

1. Remove headlamp seal cover.

GI

MA

EM

LC

EC

FE

AT

TF

PD

AX

SU

BR

ST

RS

BT

HA

SC

EL

IDX

HEADLAMP (FOR USA) — XENON TYPE —

Bulb Replacement/Xenon Type (Cont'd)

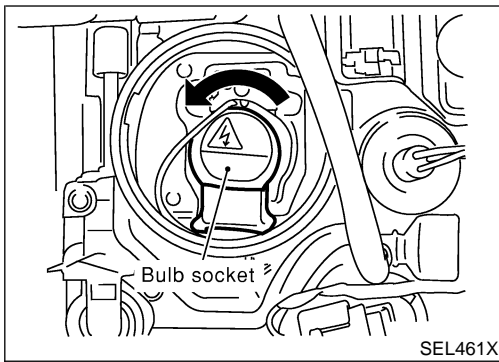

2. Turn bulb socket counterclockwise with keep pushing, then remove it.

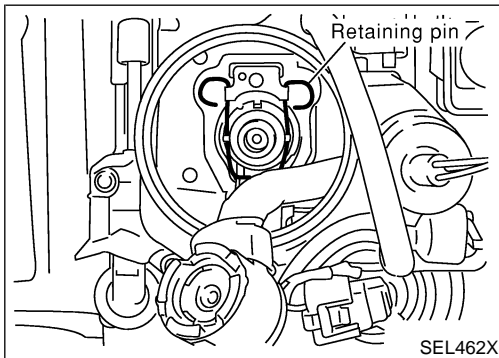

3. Release retaining pin.
4. Remove the xenon bulb.
5. Install in the reverse order of removal.

CAUTION:

- When disposing of the xenon bulb, do not break it; always dispose of it as is.
- Make sure to install the bulb securely; if the xenon bulb is improperly installed in its socket, high-tension current leaks occur. This may lead to a melted bulb and/or bulb socket.

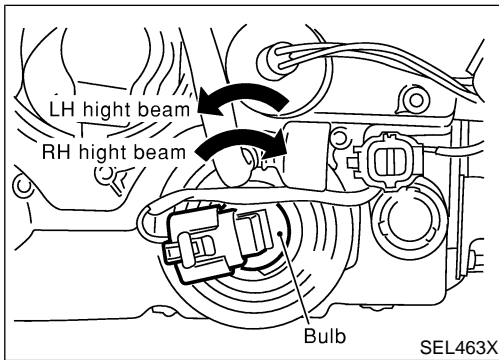

HIGH BEAM

NBEL0190S02

1. Turn the bulb counterclockwise (LH high beam) or clockwise (RH high beam).
2. Remove the bulb.
3. Install in the reverse order of removal.

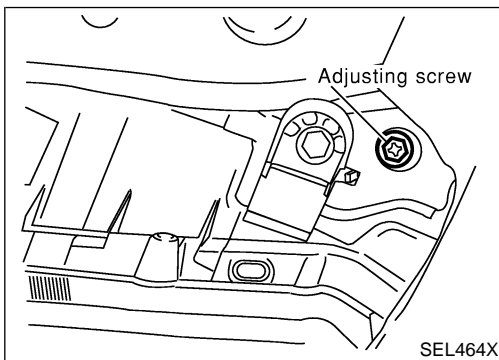

Aiming Adjustment

NBEL0191

LOW BEAM

NBEL0191S01

1. Turn headlamp low beam on.
 2. Use adjusting screws to perform aiming adjustment.
- First tighten the adjusting screw all the way and then make adjustment by loosening the screw.

HEADLAMP (FOR USA) — XENON TYPE —

Aiming Adjustment (Cont'd)

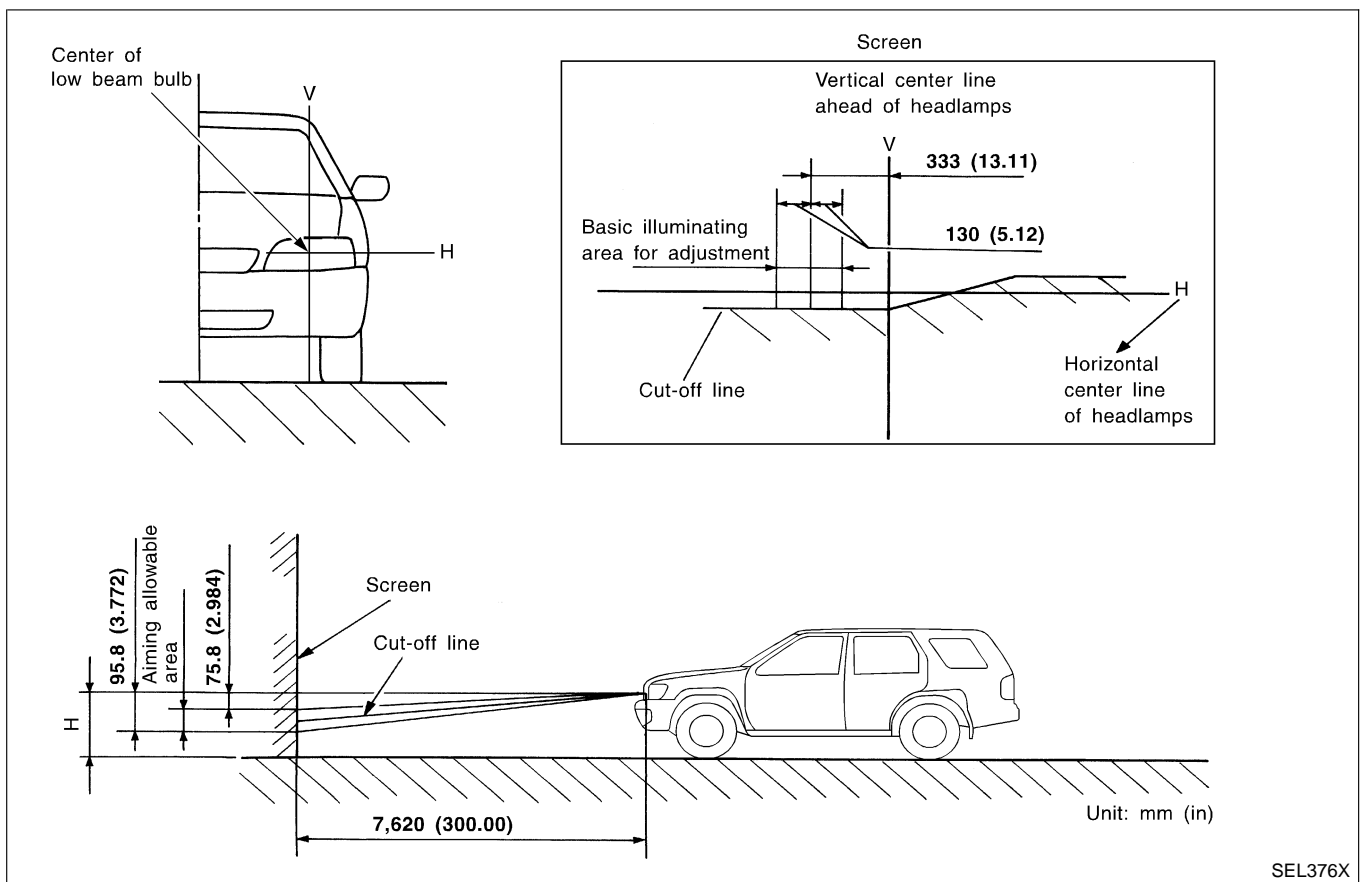

GI
MA
EM
LC
EC
FE
AT
TF
PD
AX
SU
BR
ST
RS
BT
HA
SC
EL
IDX

If the vehicle front body has been repaired and/or the headlamp assembly has been replaced, check aiming. Use the aiming chart shown in the figure.

- **Basic illuminating area for adjustment should be within the range shown on the aiming chart. Adjust headlamps accordingly.**

HEADLAMP (FOR CANADA) — DAYTIME LIGHT SYSTEM —

Component Parts and Harness Connector Location

Component Parts and Harness Connector Location

NBEL0161

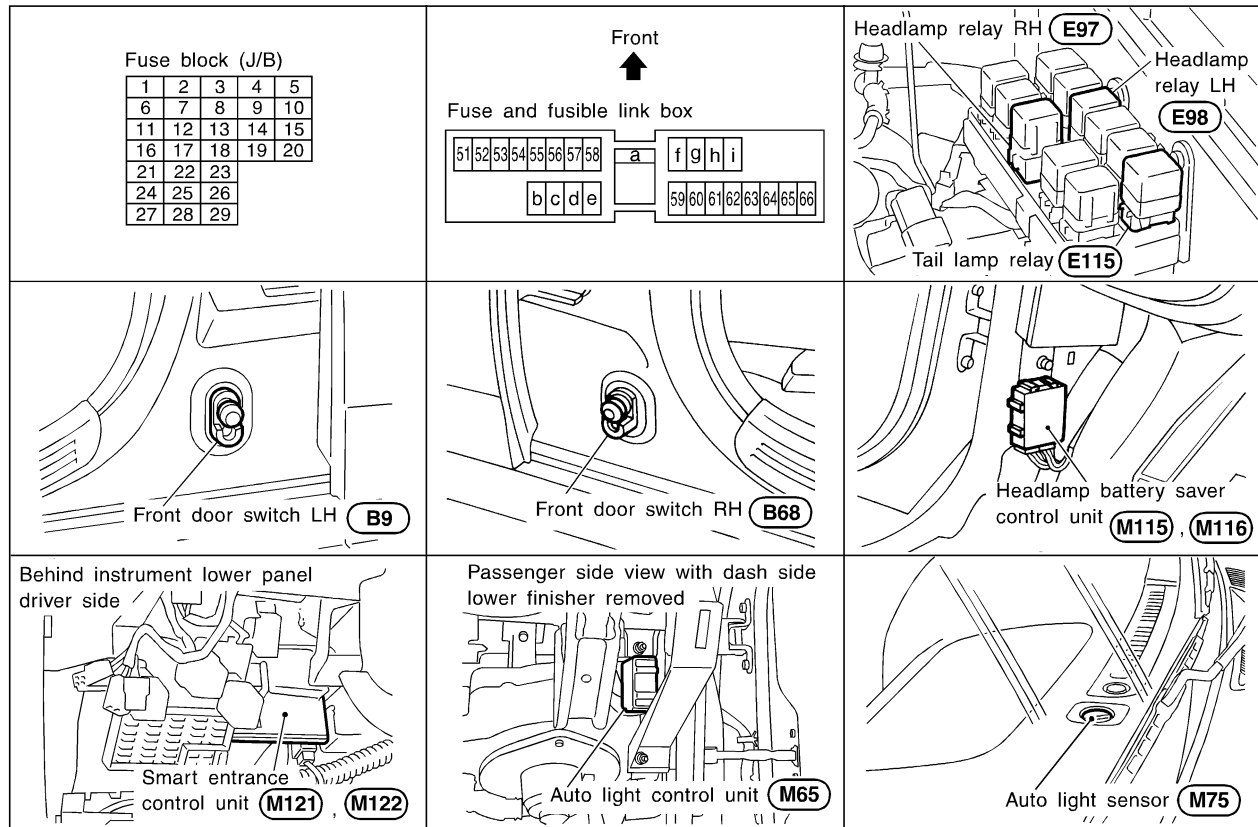

SEL460X

System Description

NBEL0192

The headlamp system for Canada vehicles contains a daytime light control unit that activates the high beam headlamps at approximately half illumination whenever the engine is running. If the parking brake is applied before the engine is started the daytime lights will not be illuminated. The daytime lights will illuminate once the parking brake is released. Thereafter, the daytime lights will continue to operate when the parking brake is applied.

And battery saver system is controlled by the headlamp battery saver control unit and smart entrance control unit.

Power is supplied at all times

- to headlamp LH relay terminals 1 and 3
- through 15A fuse (No. 60, located in the fuse and fusible link box), and
- to headlamp LH relay terminal 6
- through 20A fuse (No. 32, located in the fuse and fusible link box), and
- to headlamp RH relay terminals 1 and 3
- through 15A fuse (No. 59, located in the fuse and fusible link box), and
- to headlamp RH relay terminal 6
- through 20A fuse (No. 31, located in the fuse and fusible link box), and
- to headlamp battery saver control unit terminal 7, and
- to smart entrance control unit terminal 10
- through 7.5A fuse [No. 24, located in the fuse block (J/B)].

Ground is supplied

- to daytime light control unit terminal 16,
- to auto light control unit terminal 5 and
- to headlamp battery saver control unit terminals 4 and 11.

When the ignition switch is in the ON or START position, power is also supplied

- to daytime light control unit terminal 3,
- to auto light control unit terminal 1,
- to headlamp battery saver control unit terminal 10, and
- to smart entrance control unit terminal 33
- through 7.5A fuse [No. 11, located in the fuse block (J/B)], and
- to headlamp battery saver control unit terminal 1
- through 10A fuse [No. 16, located in the fuse block (J/B)].

GI

MA

EM

When the ignition switch is in the START position, power is supplied

- to daytime light control unit terminal 2
- through 7.5A fuse [No. 26, located in the fuse block (J/B)].

LC

When the ignition switch is in the ACC or ON position, power is supplied

- to auto light control unit terminal 2
- through 10A fuse [No. 9, located in the fuse block (J/B)].

EC

HEADLAMP OPERATION

Power Supply to Low Beam and High Beam

NBEL0192S01

FE

NBEL0192S0101

When lighting switch is in 2ND or PASS position, ground is supplied

- to headlamp relay (LH and RH) terminal 2 from headlamp battery saver control unit terminals 2 and 8
- through headlamp battery saver control unit terminal 3 and 9
- from lighting switch terminal 12.

AT

Headlamp relays (LH and RH) are energized.

TF

Low Beam Operation

When the lighting switch is turned to 2ND and LOW (“B”) positions, power is supplied

NBEL0192S0102

PD

- from terminal 7 of each headlamp relay
- to terminal 3 of each headlamp

AX

Ground is supplied

- to terminal 4 of each headlamp
- through body grounds E13 and E41.

SU

With power and ground supplied, the low beam headlamps illuminate.

High Beam Operation/Flash-to-pass Operation

When the lighting switch is turned to 2ND and HIGH (“A”) or PASS (“C”) positions, power is supplied

NBEL0192S0103

BR

- to terminal 1 of headlamp LH
- through daytime light control unit terminals 6 and 5
- from headlamp LH relay terminal 5
- to terminal 1 of headlamp RH
- through daytime light control unit terminals 7 and 4
- from headlamp RH relay terminal 5, and
- to combination meter terminal 26 for HIGH BEAM indicator
- from headlamp LH relay terminal 5.

ST

RS

BT

Ground is supplied

- to terminal 2 of LH headlamp
- through daytime light control unit terminals 10 and 13, and
- to combination meter terminal 27 for the HIGH BEAM indicator
- through lighting switch terminals 6 and 5
- through body grounds E13 and E41, and
- to terminal 2 of RH headlamp
- through daytime light control unit terminals 9 and 14
- through lighting switch terminals 9 and 8
- through body grounds E13 and E41.

HA

SC

EL

IDX

With power and ground supplied, the high beam headlamps and HIGH BEAM indicator illuminate.

HEADLAMP (FOR CANADA) — DAYTIME LIGHT SYSTEM —

System Description (Cont'd)

BATTERY SAVER CONTROL

NBEL0192S02

When the ignition switch is turned from ON (or START) to OFF (or ACC) positions while headlamps are illuminated, The RAP signal is supplied to terminal 10 of the headlamp battery saver control unit from smart entrance control unit terminal 5.

After counting 45 seconds by the RAP signal from the smart entrance control unit to headlamp battery saver control unit, the ground supply to terminal 2 of headlamp LH and RH relays from headlamp battery saver control unit terminals 2 and 8 is terminated.

Then headlamps are turned off.

The headlamps are turned off when LH or RH door is opened even if 45 seconds have not passed after the ignition switch is turned from ON (or START) to OFF (or ACC) positions while headlamps are illuminated.

When the lighting switch is turned from OFF to 2ND after headlamps are turned to off by the battery saver control, ground is supply

- to headlamp battery saver control unit terminals 5 and 13 from lighting switch terminal 11, and
- to headlamp LH and RH relays terminal 2 from headlamp battery saver control unit terminals 2 and 8
- through headlamp battery saver control unit terminals 3 and 9, and
- through lighting switch terminal 12.

Then headlamps illuminate again.

AUTO LIGHT OPERATION

NBEL0192S03

For auto light operation, refer to "HEADLAMP" (EL-33).

DAYTIME LIGHT OPERATION

NBEL0192S04

With the engine running, the lighting switch in the OFF or 1ST position and parking brake released, power is supplied

- through daytime light control unit terminals 3 and 7
- to terminal 1 of RH headlamp
- through terminal 2 of RH headlamp
- to daytime light control unit terminal 9
- through daytime light control unit terminal 6
- to terminal 1 of LH headlamp.

Ground is supplied to terminal 2 of LH headlamp.

- through daytime light control unit terminals 10 and 16
- through body grounds E13 and E41.

Because the high beam headlamps are now wired in series, they operate at half illumination.

HEADLAMP (FOR CANADA) — DAYTIME LIGHT SYSTEM —

System Description (Cont'd)

OPERATION

=NBEL0192S05

After starting the engine with the lighting switch in the “OFF” or “1ST” position, the headlamp high beam automatically turns on. Lighting switch operations other than the above are the same as conventional light systems.

Engine		With engine stopped									With engine running								
Lighting switch		OFF			1ST			2ND			OFF			1ST			2ND		
		A	B	C	A	B	C	A	B	C	A	B	C	A	B	C	A	B	C
Headlamp	High beam	X	X	O	X	X	O	O	X	O	△*	△*	O	△*	△*	O	O	X	O
	Low beam	X	X	X	X	X	X	X	O	X	X	X	X	X	X	X	X	O	X
Clearance and tail lamp		X	X	X	O	O	O	O	O	O	X	X	X	O	O	O	O	O	O
License and instrument illumination lamp		X	X	X	O	O	O	O	O	O	X	X	X	O	O	O	O	O	O

A: “HIGH BEAM” position

B: “LOW BEAM” position

C: “FLASH TO PASS” position

O : Lamp “ON”

X : Lamp “OFF”

△ : Lamp dims. (Added functions)

*: When starting the engine with the parking brake released, the daytime light will come ON.

When starting the engine with the parking brake pulled, the daytime light won't come ON.

GI

MA

EM

LC

EC

FE

AT

TF

PD

AX

SU

BR

ST

RS

BT

HA

SC

EL

IDX

HEADLAMP (FOR CANADA) — DAYTIME LIGHT SYSTEM —

Schematic

Schematic

NBEL0019

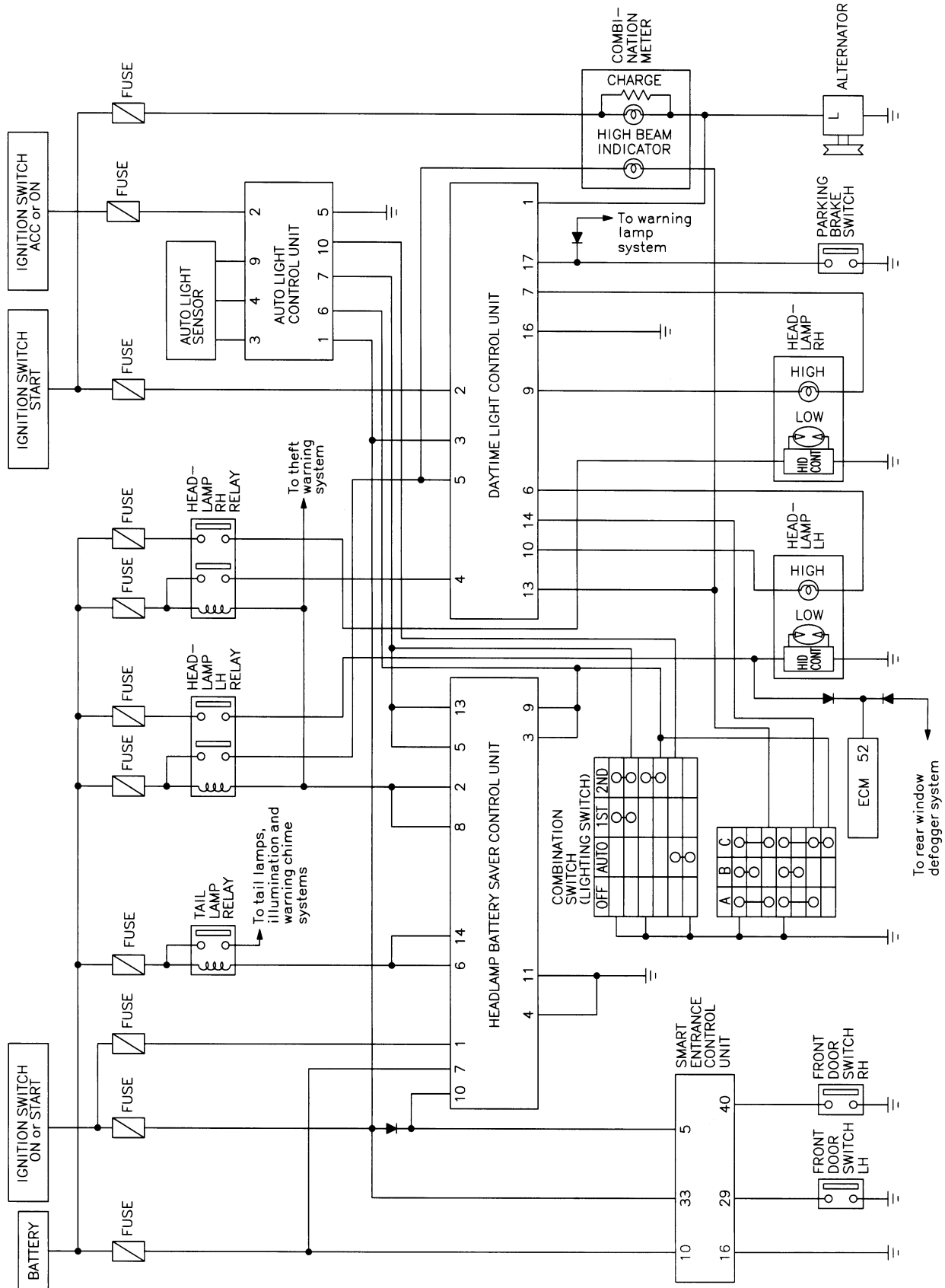

MEL766L

HEADLAMP (FOR CANADA) — DAYTIME LIGHT SYSTEM —

Wiring Diagram — DTRL —

Wiring Diagram — DTRL —

NBEL0020

EL-DTRL-01

GI

MA

EM

LC

EC

FE

AT

TF

PD

AX

SU

BR

ST

RS

BT

HA

SC

EL

IDX

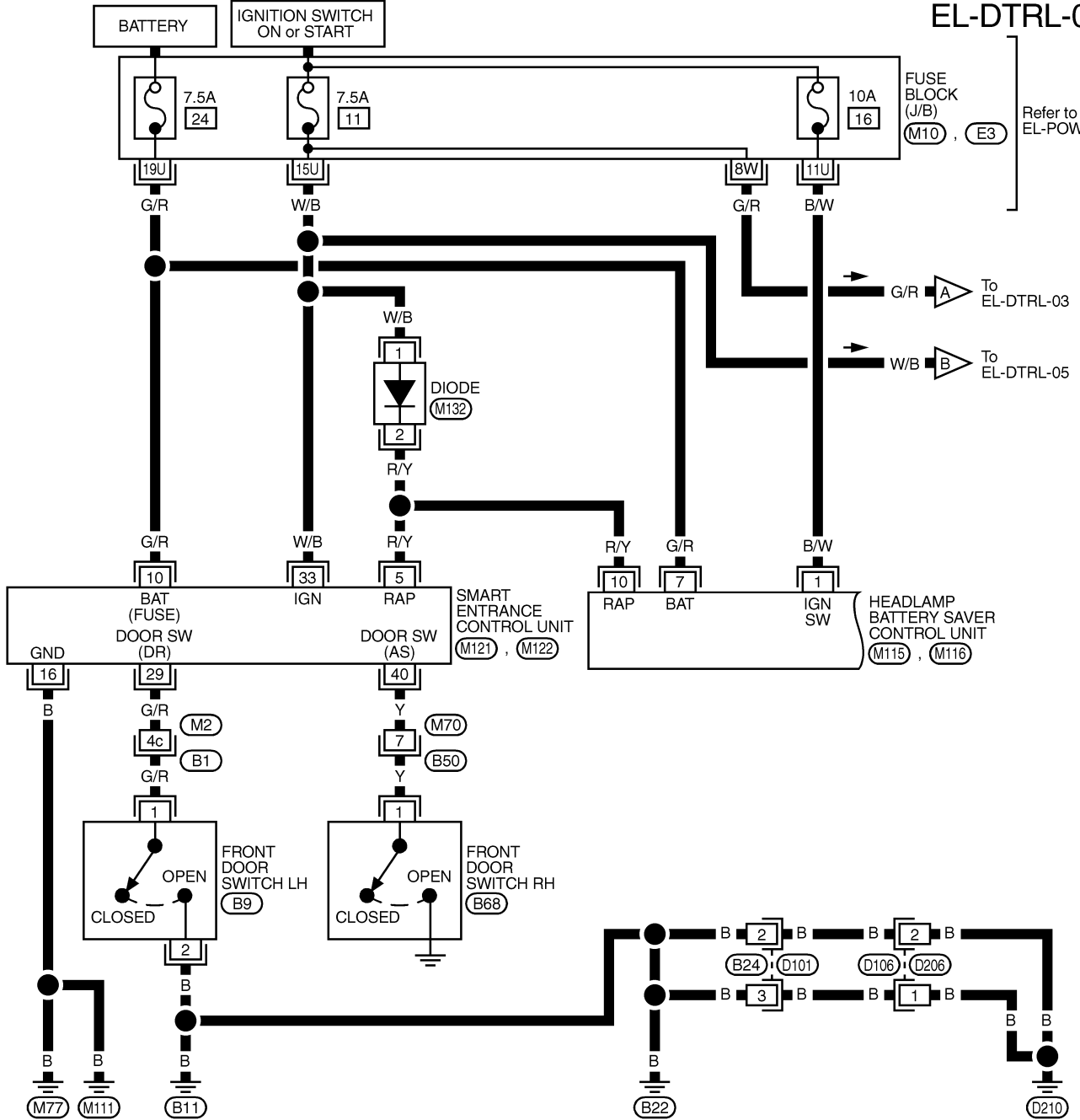

Refer to EL-POWER.

REFER TO THE FOLLOWING.
 (B1) -SUPER MULTIPLE JUNCTION (SMJ)
 (M10), (E3) -FUSE BLOCK-JUNCTION BOX (J/B)

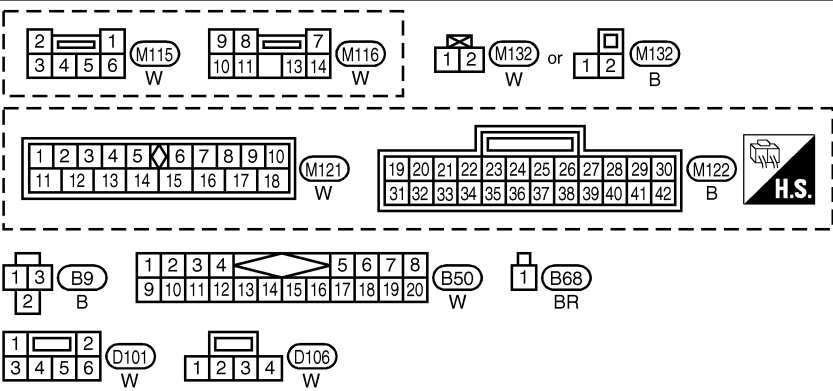

MEL0020

HEADLAMP (FOR CANADA) — DAYTIME LIGHT SYSTEM —

Wiring Diagram — DTRL — (Cont'd)

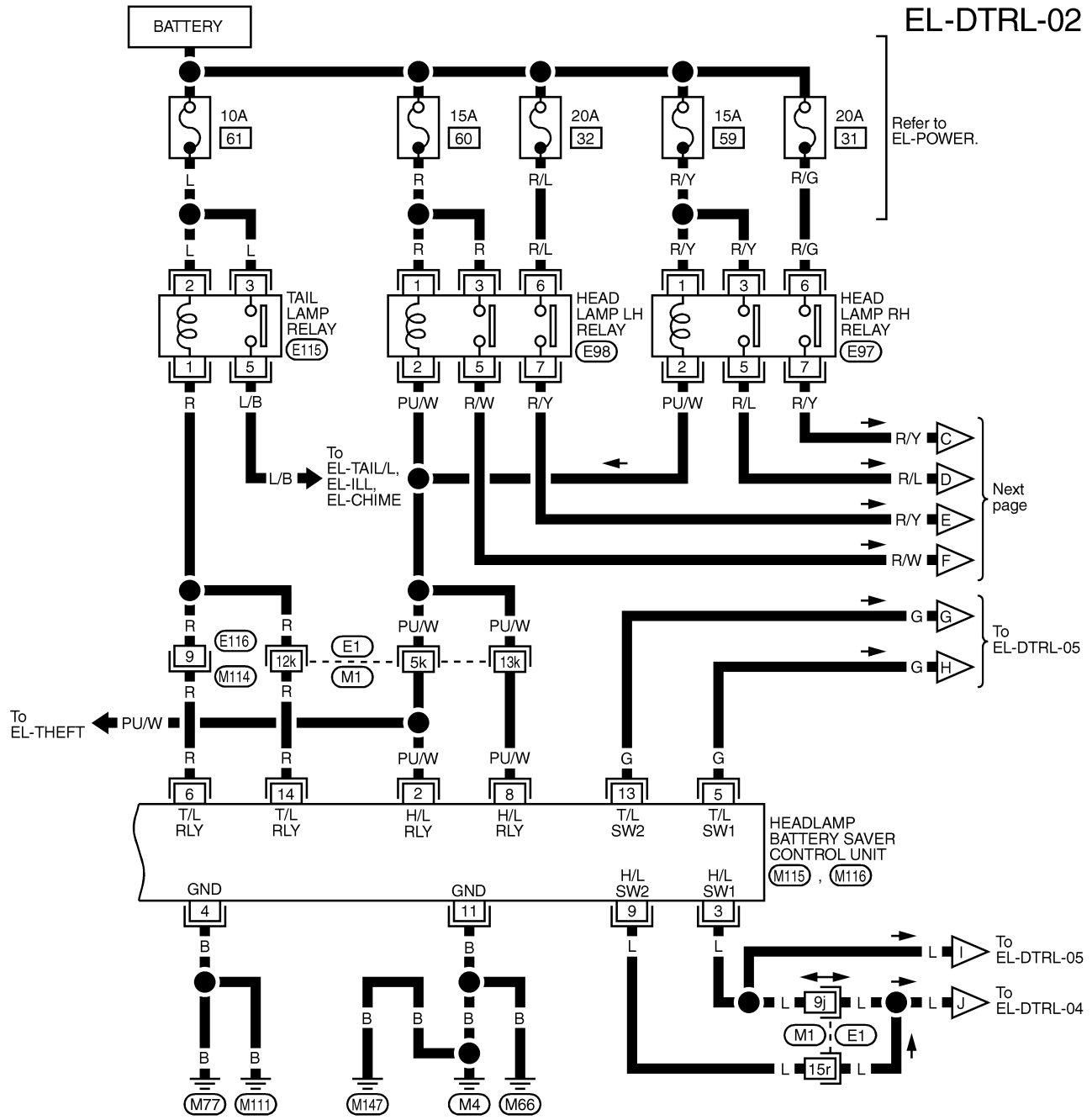

EL-DTRL-02

Refer to EL-POWER.

Next page

To EL-DTRL-05

To EL-DTRL-05

To EL-DTRL-04

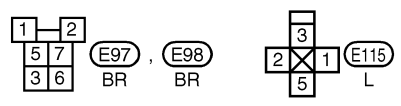
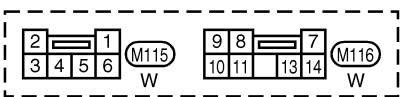
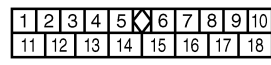

REFER TO THE FOLLOWING.

(E1) -SUPER
MULTIPLE JUNCTION (SMJ)

MEL768L

HEADLAMP (FOR CANADA) — DAYTIME LIGHT SYSTEM —

Wiring Diagram — DTRL — (Cont'd)

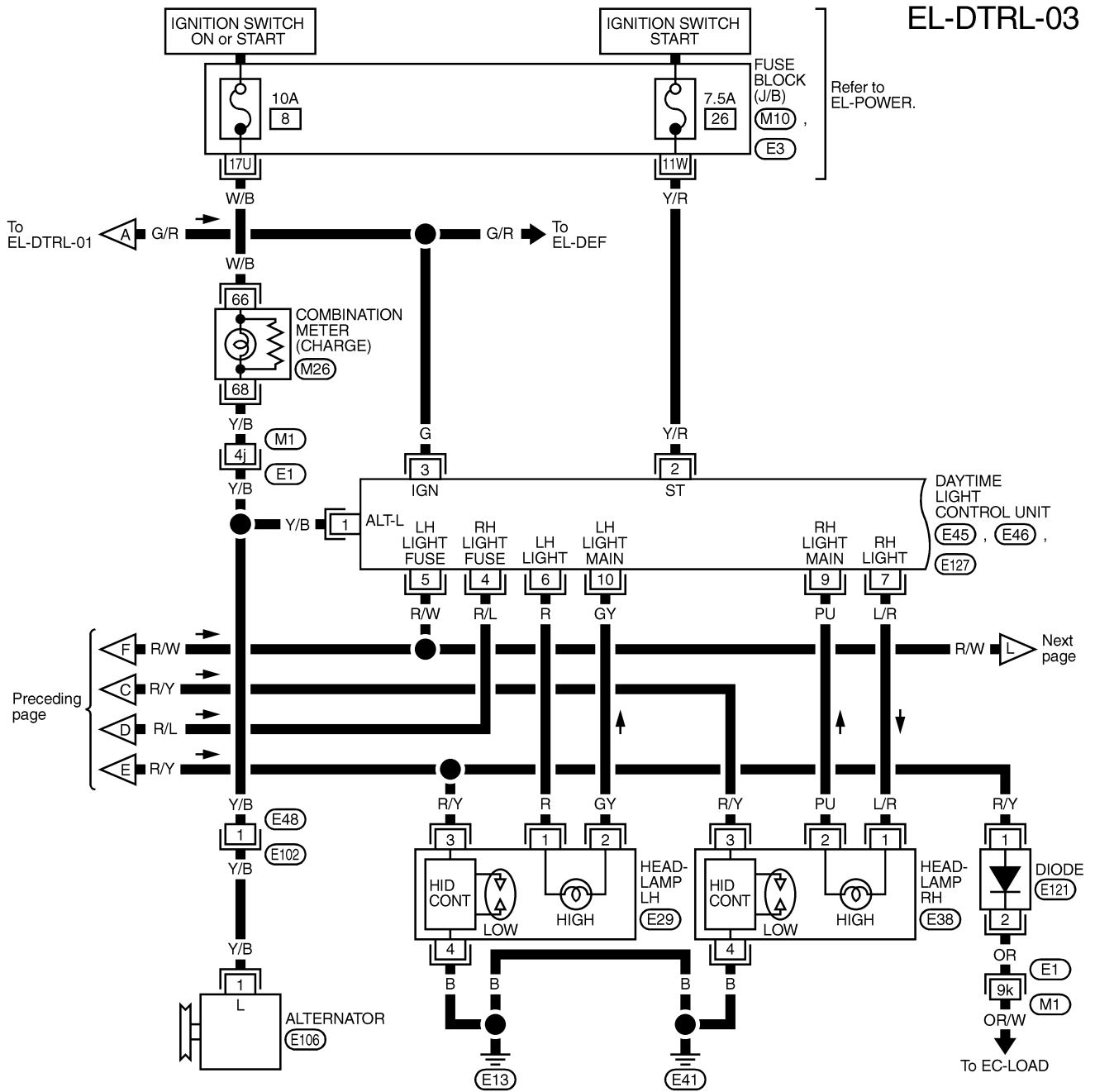

EL-DTRL-03

Refer to EL-POWER.

GI
MA
EM
LC
EC
FE
AT
TF
PD
AX
SU
BR
ST
RS
BT
HA
SC
EL
IDX

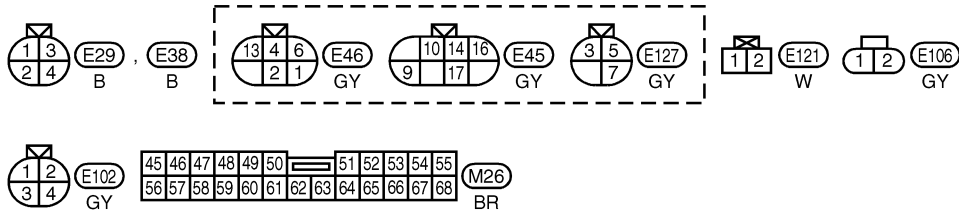

REFER TO THE FOLLOWING.

- (E1) -SUPER
- MULTIPLE JUNCTION (SMJ)
- (M10), (E3) -FUSE BLOCK-JUNCTION (J/B)

HEADLAMP (FOR CANADA) — DAYTIME LIGHT SYSTEM —

Wiring Diagram — DTRL — (Cont'd)

EL-DTRL-04

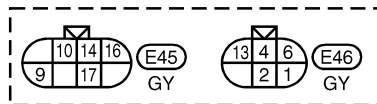
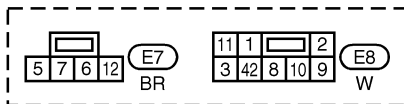
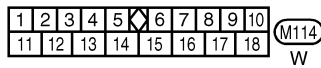
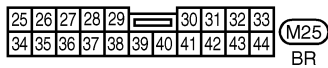
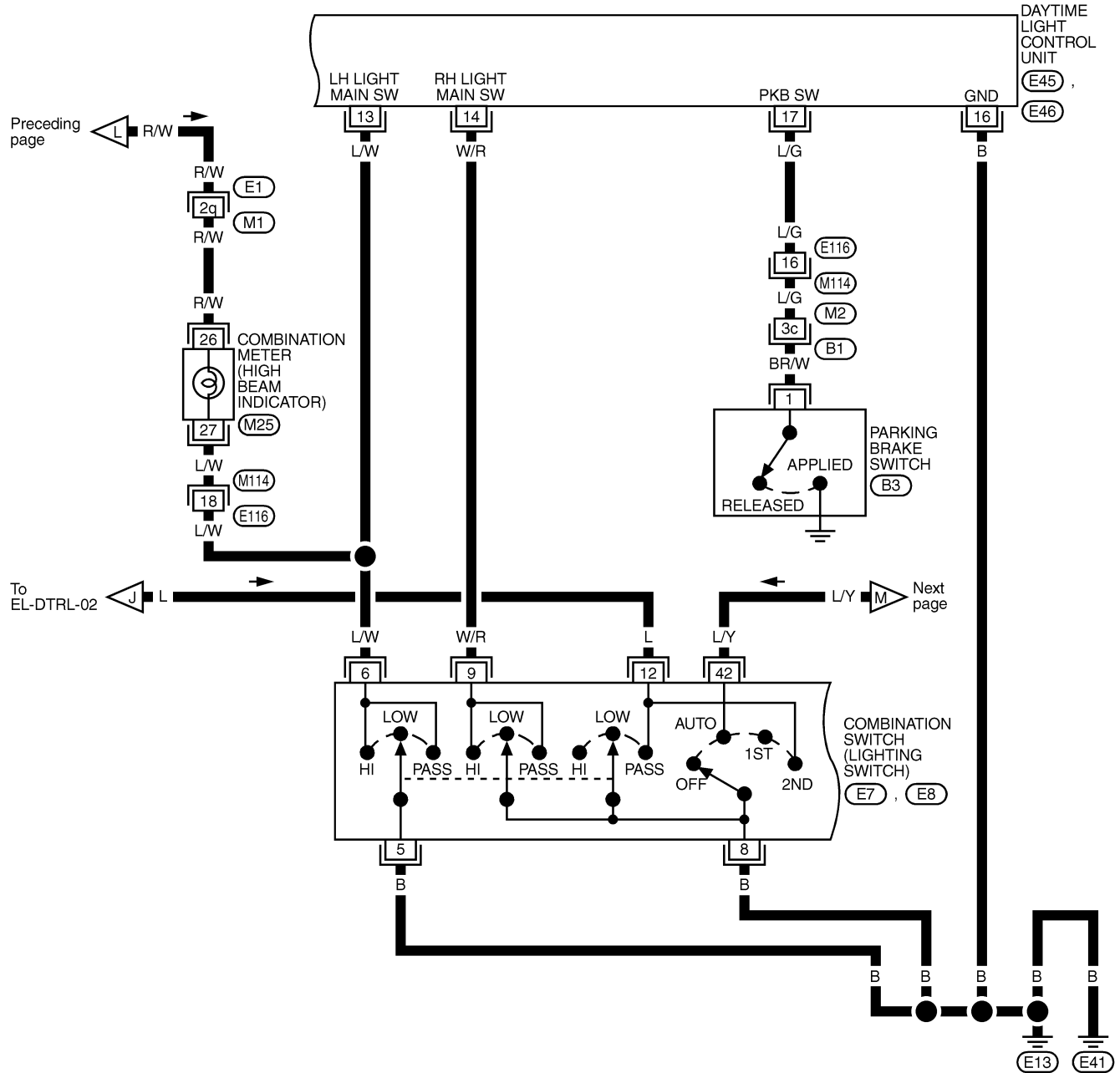

REFER TO THE FOLLOWING.

(E1), (B1) - SUPER
MULTIPLE JUNCTION (SMJ)

MEL770L

HEADLAMP (FOR CANADA) — DAYTIME LIGHT SYSTEM —

Wiring Diagram — DTRL — (Cont'd)

EL-DTRL-05

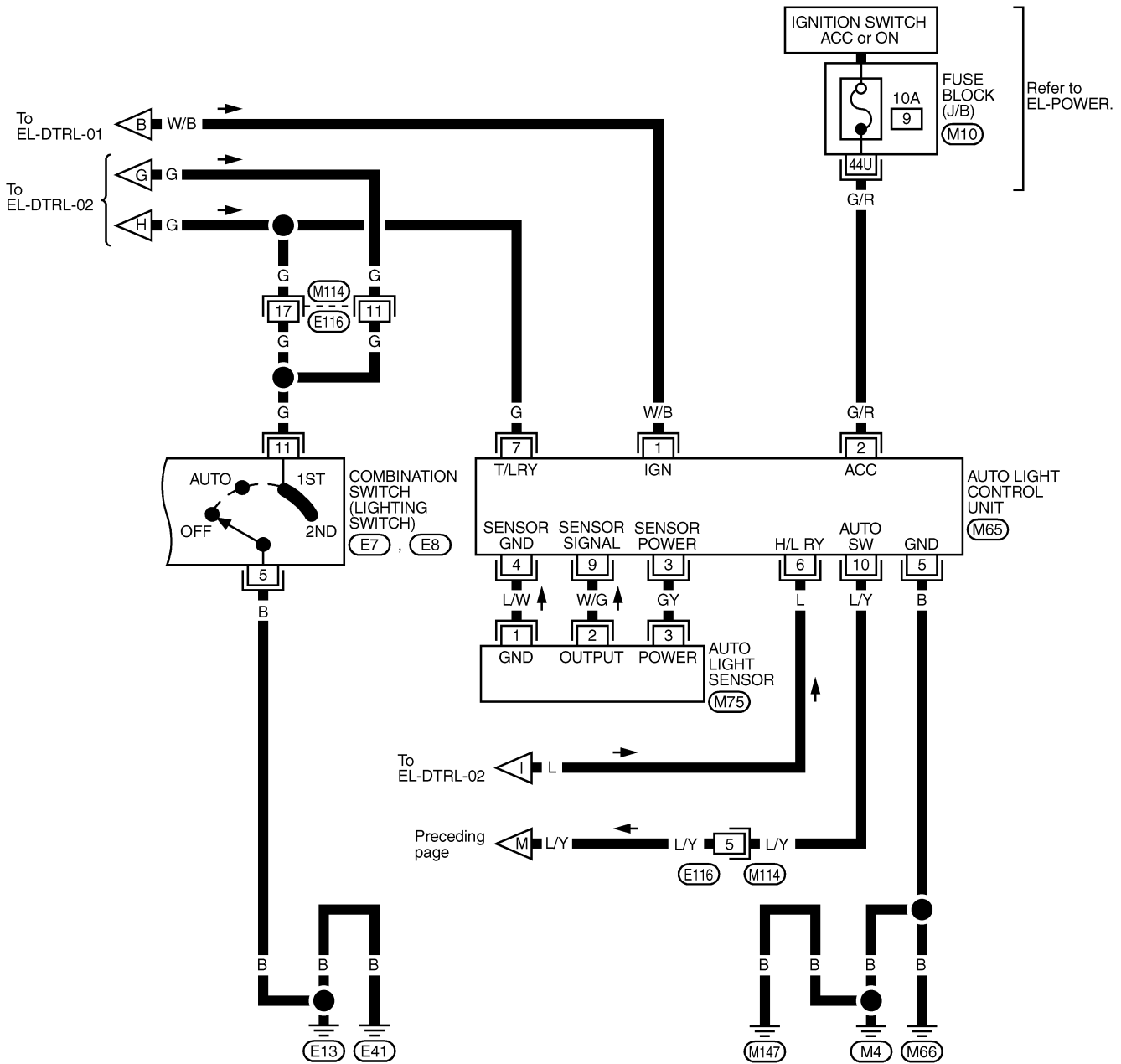

GI
MA
EM
LC
EC
FE
AT
TF
PD
AX
SU
BR
ST
RS
BT
HA
SC
EL
IDX

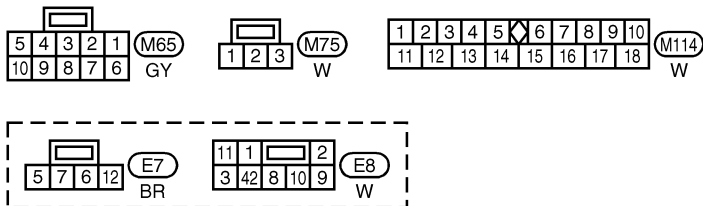

REFER TO THE FOLLOWING.

(M10) - FUSE BLOCK-
JUNCTION BOX (J/B)

MEL771L

HEADLAMP (FOR CANADA) — DAYTIME LIGHT SYSTEM —















Trouble Diagnoses

Trouble Diagnoses

NBEL0193







DAYTIME LIGHT CONTROL UNIT INSPECTION TABLE

NBEL0193S01

Terminal No.	Wire color	Item	Condition		Voltage (Approximate values)
1	Y/B	Alternator		When turning ignition switch to "ON"	Less than 1V
				When engine is running	Battery voltage
				When turning ignition switch to "OFF"	Less than 1V
2	Y/R	Start signal		When turning ignition switch to "ST"	Battery voltage
				When turning ignition switch to "ON" from "ST"	Less than 1V
				When turning ignition switch to "OFF"	Less than 1V
3	G	Power source		When turning ignition switch to "ON"	Battery voltage
				When turning ignition switch to "ST"	Battery voltage
				When turning ignition switch to "OFF"	Less than 1V
4	R/L	Power source		When turning ignition switch to "ON"	Battery voltage
				When turning ignition switch to "OFF"	Battery voltage
5	R/W	Power source		When turning ignition switch to "ON"	Battery voltage
				When turning ignition switch to "OFF"	Battery voltage
6	R	LH hi beam		When lighting switch is turned to the 2ND position with "HI BEAM" position	Battery voltage
			 	When releasing parking brake with engine running and turning lighting switch to "OFF" (daytime light operation) CAUTION: Block wheels and ensure selector lever is in N or P position.	Approx. half battery voltage

HEADLAMP (FOR CANADA) — DAYTIME LIGHT SYSTEM —

Trouble Diagnoses (Cont'd)

Terminal No.	Wire color	Item	Condition	Voltage (Approximate values)	
7	L/R	RH hi beam		When lighting switch is turned to the 2ND position with "HI BEAM" position	Battery voltage
			 	When releasing parking brake with engine running and turning lighting switch to "OFF" (daytime light operation) CAUTION: Block wheels and ensure selector lever is in N or P position.	Approx. half battery voltage
9	PU	RH hi beam (ground)		When lighting switch is turned to the 2ND position with "HI BEAM" position	Less than 1V
			 	When releasing parking brake with engine running and turning lighting switch to "OFF" (daytime light operation) CAUTION: Block wheels and ensure selector lever is in N or P position.	Approx. half battery voltage
10	GY	LH hi beam (ground)		When lighting switch is turned to the 2ND position with "HI BEAM" position	Less than 1V
			 	When releasing parking brake with engine running and turning lighting switch to "OFF" (daytime light operation) CAUTION: Block wheels and ensure selector lever is in N or P position.	Approx. half battery voltage
13	L/W	Lighting switch (Hi beam)		When turning lighting switch to "HI BEAM"	Battery voltage
14	W/R			When turning lighting switch to "FLASH TO PASS"	Battery voltage
16	B	Ground	—	—	
17	L/G	Parking brake switch		When parking brake is released	Battery voltage
				When parking brake is set	Less than 1.5V

BATTERY SAVER CONTROL UNIT INSPECTION TABLE

Refer to "HEADLAMP (FOR USA)", EL-42.

NBEL0193S02

Bulb Replacement

Refer to "HEADLAMP (FOR USA)" (EL-43).

NBEL0194

EL

IDX

HEADLAMP (FOR CANADA) — DAYTIME LIGHT SYSTEM —

Aiming Adjustment

Aiming Adjustment

Refer to “HEADLAMP (FOR USA)” (EL-44).

NBEL0195

System Description

NBEL0196

The headlamp aiming operation is controlled by the headlamp aiming switch. Power is supplied at all times.

- through 10A fuse (No. 61, located in fuse and fusible link box)
- to tail lamp relay terminal 2 and 3.

When lighting switch is in 1ST or 2ND position, ground is supplied

- to tail lamp relay terminal 1.
- through lighting switch and body grounds E13 and E41, and then tail lamp relay is energized.

When auto light operation is performed, ground is supplied

- to tail lamp relay terminal 1
- through auto light control unit terminal 7,

and then tail lamp relay is energized.

When tail lamp relay is energized, power is supplied

- from tail lamp relay terminal 5
- to terminal 1 of each headlamp aiming motor.

Ground is supplied

- to terminal 3 of each headlamp aiming motor
- through body grounds E13 and E41,
- to terminal 2 of each headlamp aiming motor
- through headlamp aiming switch and body grounds E13 and E41.

With power and ground supplied, headlamp aiming motors operate according to the aiming switch position.

GI

MA

EM

LC

EC

FE

AT

TF

PD

AX

SU

BR

ST

RS

BT

HA

SC

EL

IDX

HEADLAMP — HEADLAMP AIMING CONTROL —

Wiring Diagram — H/AIM —

Wiring Diagram — H/AIM —

NBEL0197

EL-H/AIM-01

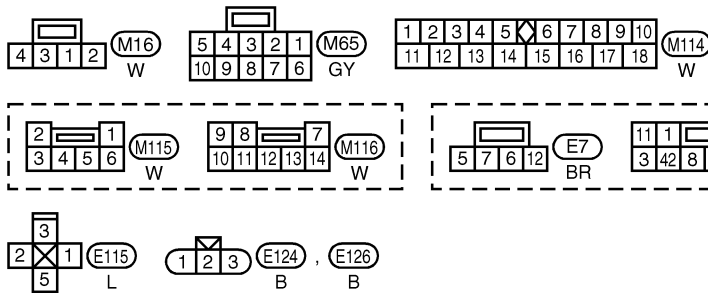
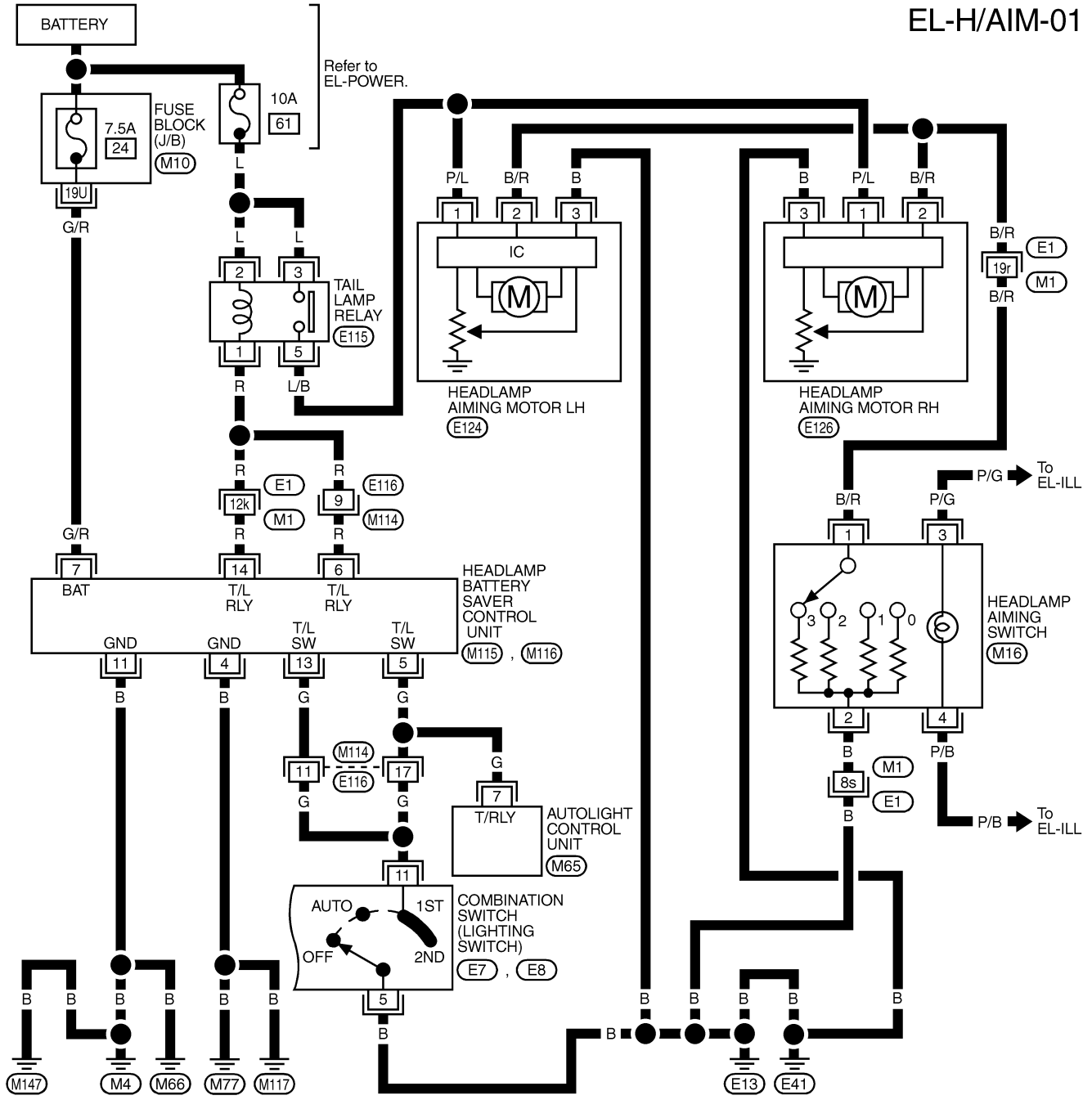

REFER TO THE FOLLOWING.

- (E1) -SUPER
- MULTIPLE JUNCTION (SMJ)
- (M10) -FUSE BLOCK-
- JUNCTION BOX (J/B)

MEL772L

System Description

NBEL0162

The parking, license and tail lamp operation is controlled by the lighting switch which is built into the combination switch and headlamp battery saver control unit. The battery saver system is controlled by the headlamp battery saver control unit and smart entrance control unit.

Power is supplied at all times

- to tail lamp relay terminals 2 and 3
- through 10A fuse (No. 61, located in the fuse and fusible link box), and
- to headlamp battery saver control unit terminal 7, and
- to smart entrance control unit terminal 10
- through 7.5A fuse [No. 24, located in the fuse block (J/B)].

When ignition switch is in ON or START position, power is supplied

- to headlamp battery saver control unit terminal 1
- through 10A fuse [No. 16, located in the fuse block (J/B)], and
- to headlamp battery saver control unit terminal 10, and
- to smart entrance control unit terminal 33
- through 7.5A fuse [No. 11, located in the fuse block (J/B)].

Ground is supplied to headlamp battery saver control unit terminals 4 and 11.

LIGHTING OPERATION BY LIGHTING SWITCH

NBEL0162S01

When lighting switch is in 1ST (or 2ND) position, ground is supplied

- to tail lamp relay terminal 1 from headlamp battery saver control unit terminals 6 and 14
- through headlamp battery saver control unit terminals 5 and 13, and
- to combination switch (lighting switch) terminal 11
- through combination switch (lighting switch) terminal 5
- through body grounds E13 and E41.

Tail lamp relay is then energized and the parking, license and tail lamps illuminate.

LIGHTING OPERATION BY AUTO LIGHT CONTROL SYSTEM

NBEL0162S03

When auto light control system is operated, ground is supplied

- to tail lamp relay terminal 1 from headlamp battery saver control unit terminals 6 and 14
- through headlamp battery saver control unit terminals 5 and 13, and
- through auto light control unit terminal 7.

Tail lamp relay is then energized and the parking, license and tail lamps illuminate.

BATTERY SAVER CONTROL

NBEL0162S02

When the ignition switch is turned from ON (or START) to OFF (or ACC) positions while parking, license and tail lamps are illuminated, the RAP signal is supplied to terminal 10 of the headlamp battery saver control unit from smart entrance control unit terminal 5.

After counting 45 seconds by the RAP signal from the smart entrance control unit to headlamp battery saver control unit, the ground supply to terminal 1 of the tail lamp relay from headlamp battery saver control unit terminals 6 and 14 is terminated.

Then the parking, license and tail lamps are turned off.

The parking, license and tail lamps are turned off when driver or passenger side door is opened even if 45 seconds have not passed after the ignition switch is turned from ON (or START) to OFF (or ACC) positions while parking, license and tail lamps are illuminated.

When the lighting switch is turned from OFF to 1ST (or 2ND) after the parking, license and tail lamps are turned off by the battery saver control, ground is supplied.

- to headlamp battery saver control unit terminals 5 and 13 from lighting switch terminal 11, and
- to tail lamp relay terminal 1 from headlamp battery saver control unit terminals 6 and 14.

Then the parking, license and tail lamps illuminate again.

GI

MA

EM

LC

EC

FE

AT

TF

PD

AX

SU

BR

ST

RS

BT

HA

SC

EL

IDX

PARKING, LICENSE AND TAIL LAMPS

Schematic

Schematic

NBEL0163

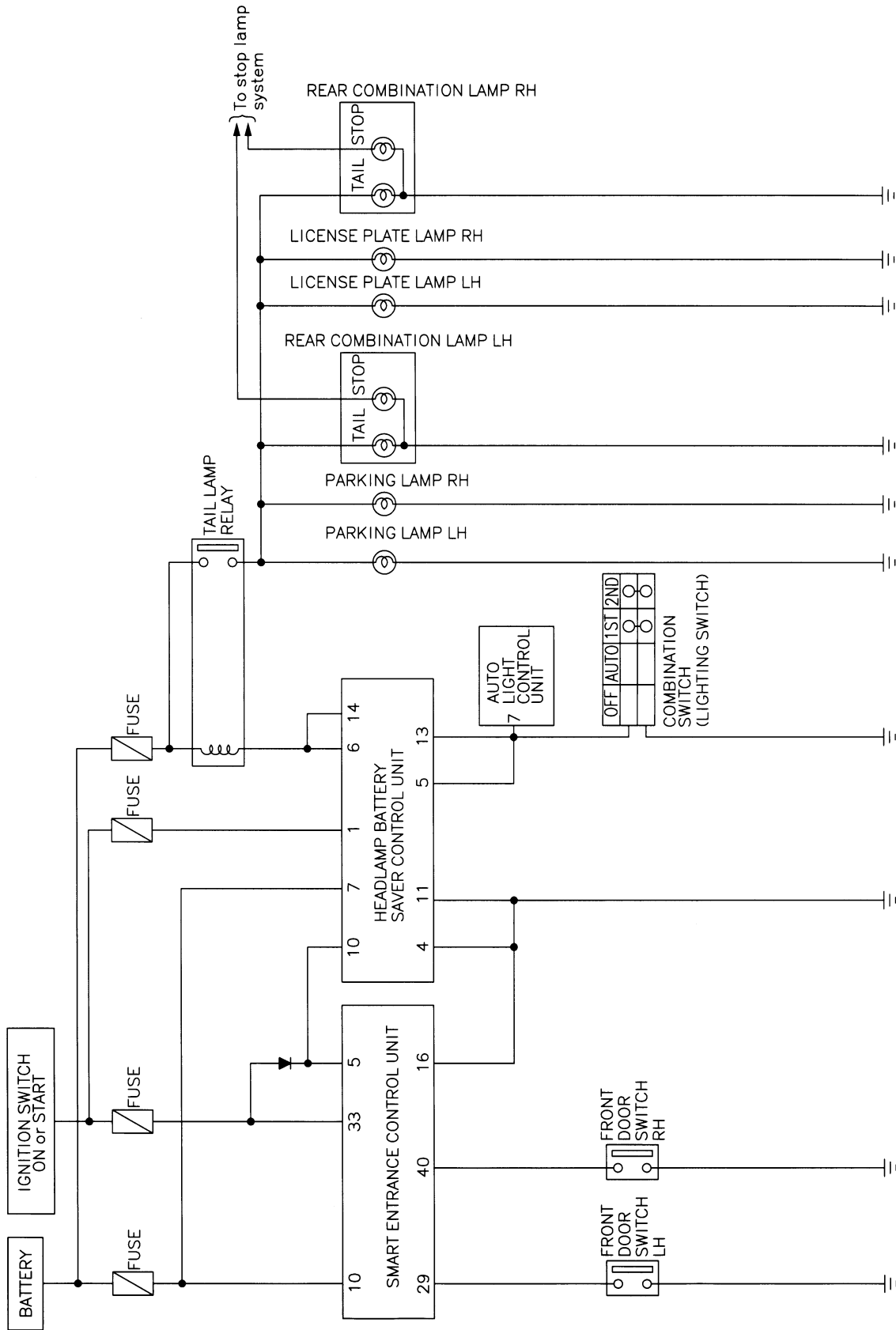

MEL773L

PARKING, LICENSE AND TAIL LAMPS

Wiring Diagram — TAIL/L —

Wiring Diagram — TAIL/L —

NBEL0024

EL-TAIL/L-01

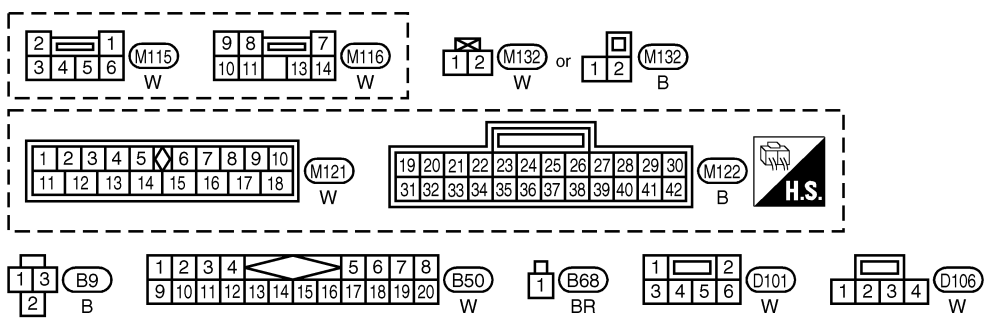
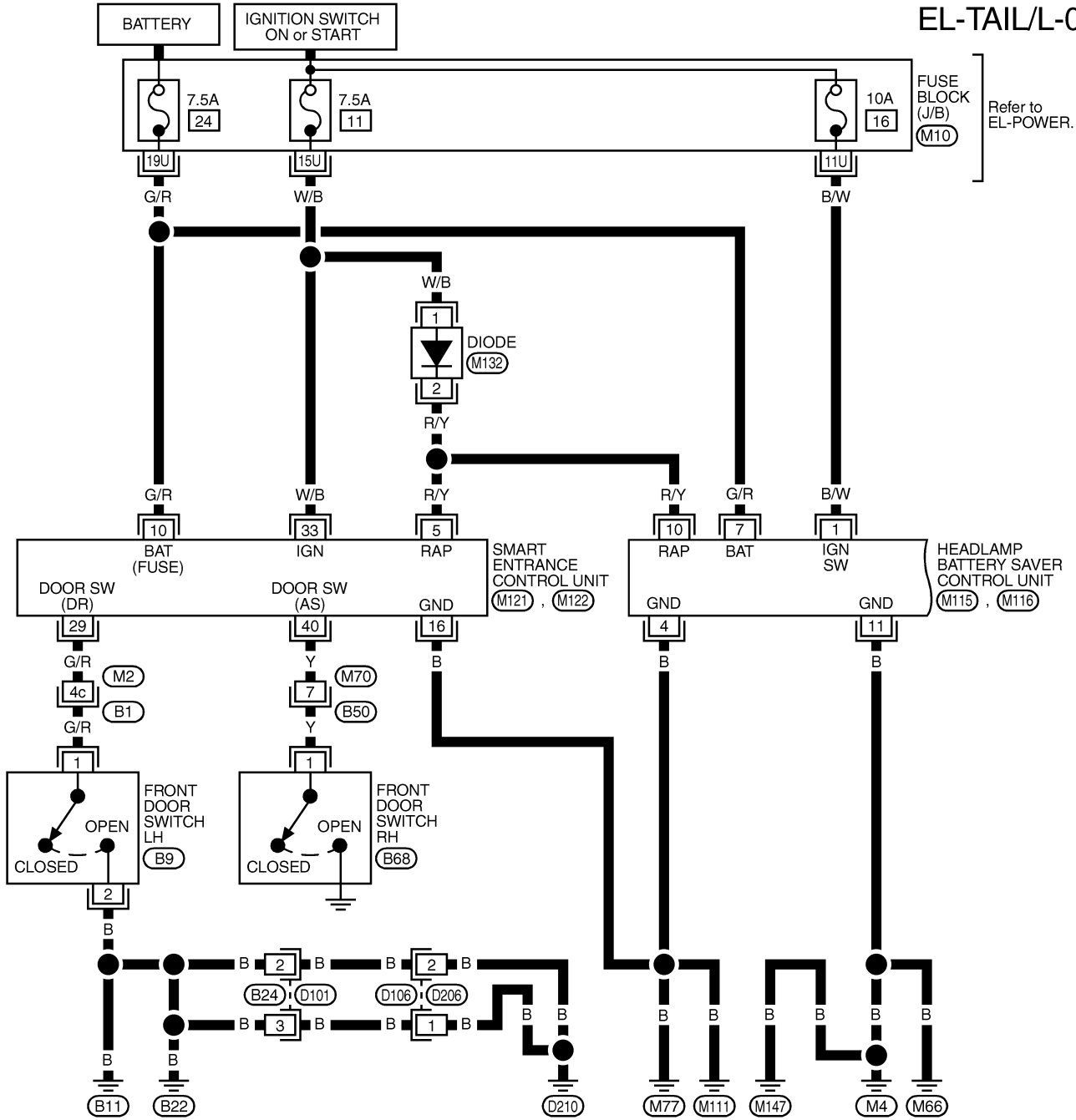

REFER TO THE FOLLOWING
 (B1) -SUPER MULTIPLE
 JUNCTION (SMJ)
 (M10) -FUSE BLOCK-
 JUNCTION BOX (J/B)

GI
 MA
 EM
 LC
 EC
 FE
 AT
 TF
 PD
 AX
 SU
 BR
 ST
 RS
 BT
 HA
 SC
 EL
 IDX

MEL0030

PARKING, LICENSE AND TAIL LAMPS

Wiring Diagram — TAIL/L — (Cont'd)

EL-TAIL/L-02

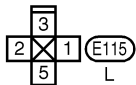
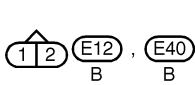
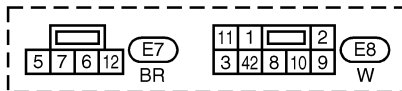
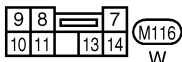
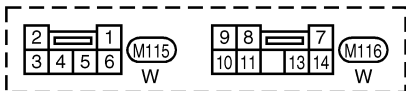
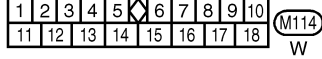
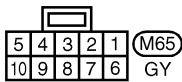
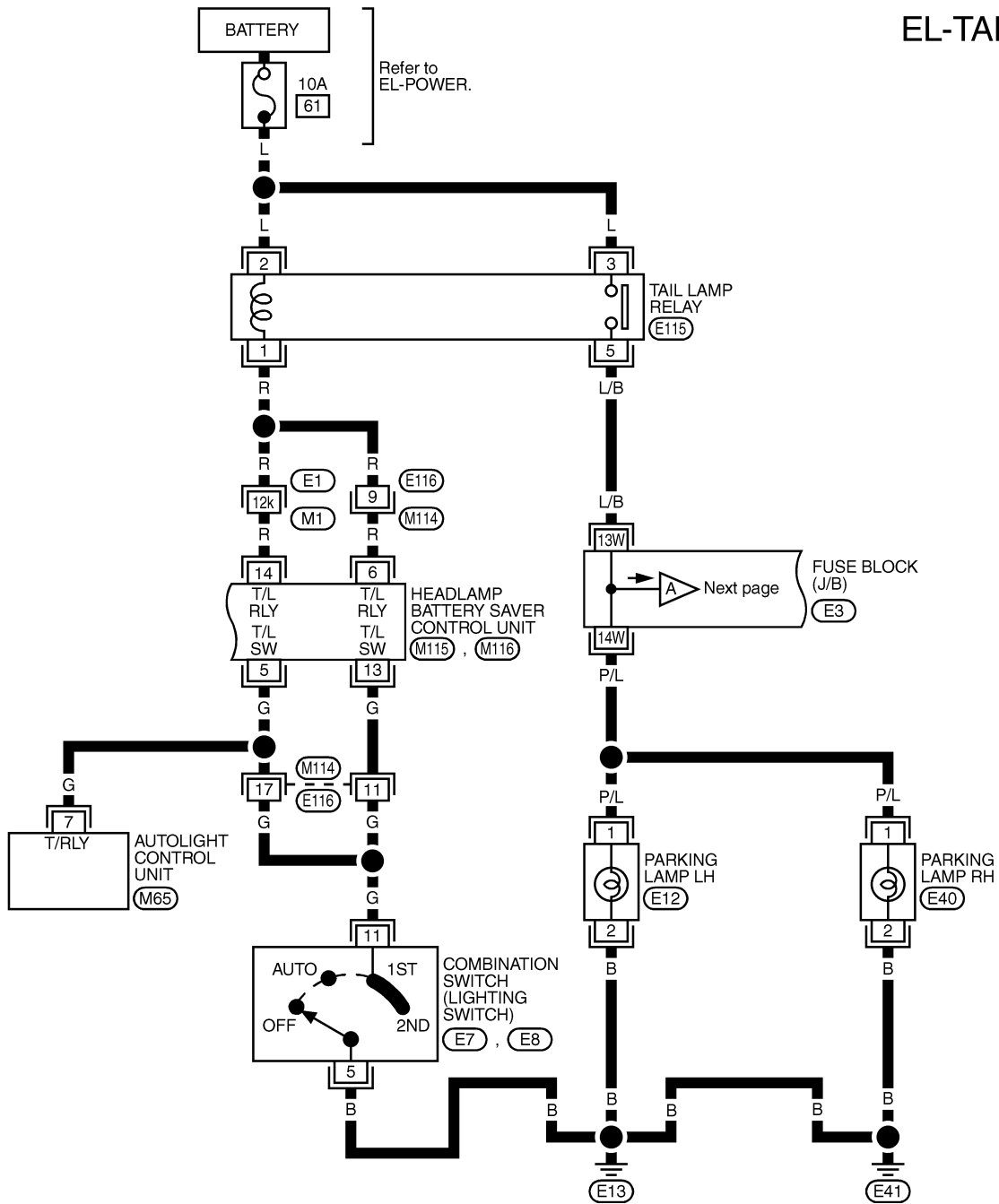

REFER TO THE FOLLOWING.

- (E1) -SUPER
- MULTIPLE JUNCTION (SMJ)
- (E3) -FUSE BLOCK-
- JUNCTION BOX (J/B)

MEL775L

PARKING, LICENSE AND TAIL LAMPS

Wiring Diagram — TAIL/L — (Cont'd)

EL-TAIL/L-03

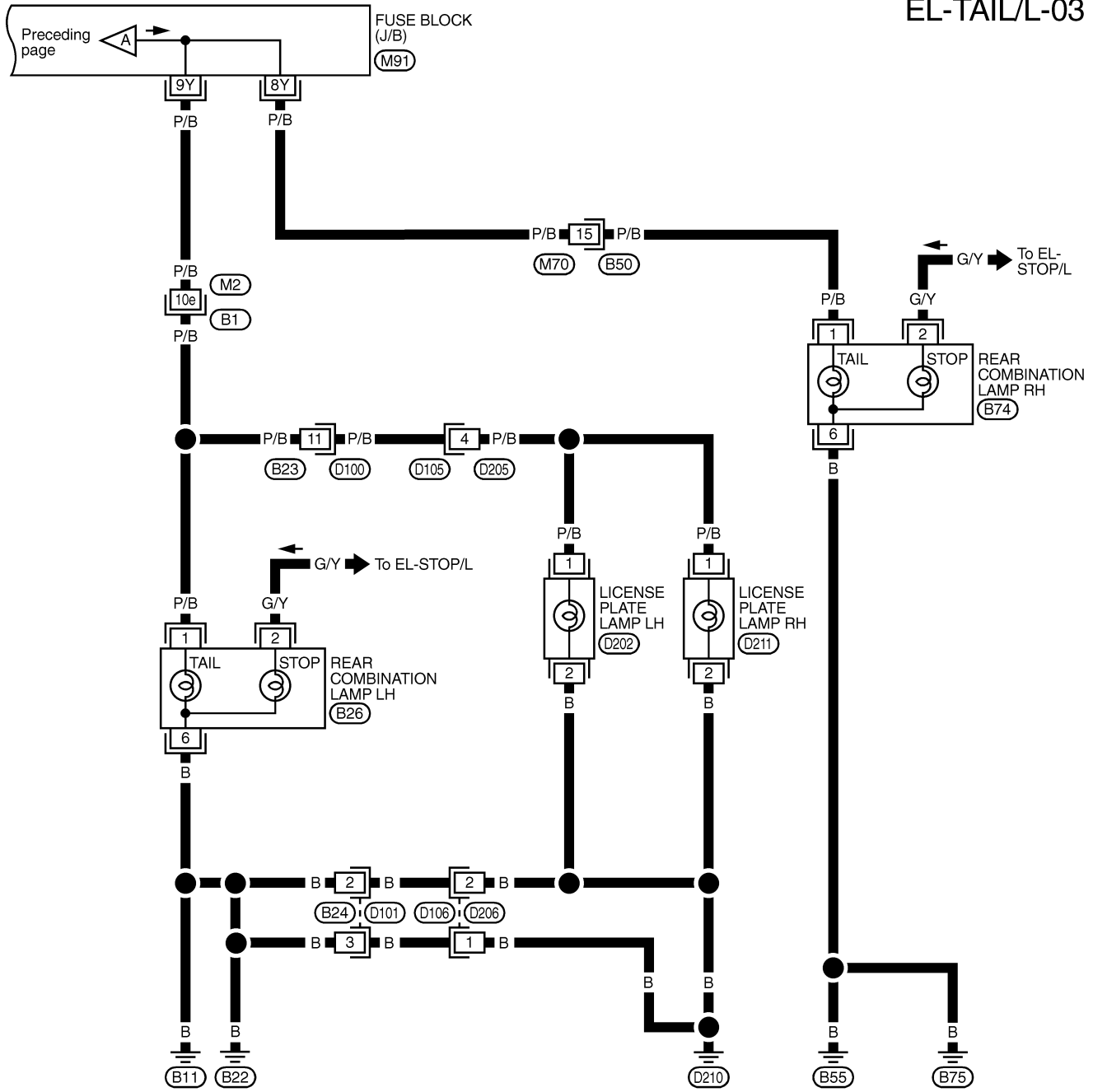

GI
MA
EM
LC
EC
FE
AT
TF
PD
AX
SU
BR
ST
RS
BT
HA
SC
EL
IDX

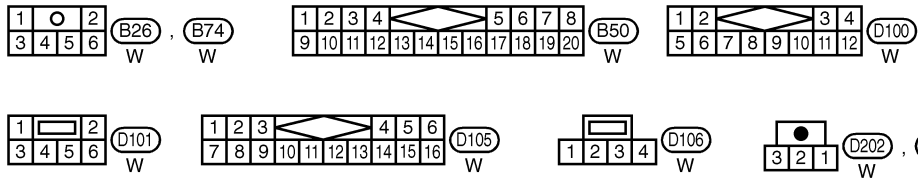

REFER TO THE FOLLOWING.
 (B1) -SUPER
 MULTIPLE JUNCTION (SMJ)
 (M91) -FUSE BLOCK-
 JUNCTION BOX (J/B)

MEL776L

PARKING, LICENSE AND TAIL LAMPS

Trouble Diagnoses

Trouble Diagnoses

NBEL0164

Symptom	Possible cause	Repair order
No lamps operate (including headlamps).	<ol style="list-style-type: none"> 1. 7.5A fuse 2. Lighting switch 3. Headlamp battery saver control unit 	<ol style="list-style-type: none"> 1. Check 7.5A fuse [No. 24, located in fuse block (J/B)]. Verify battery positive voltage is present at terminal 7 of headlamp battery saver control unit. 2. Check lighting switch. 3. Check headlamp battery saver control unit. (EL-42)
No parking, license and tail lamps operate, but headlamps do operate.	<ol style="list-style-type: none"> 1. 10A fuse 2. Tail lamp relay 3. Tail lamp relay circuit 4. Lighting switch 5. Lighting switch circuit 6. Headlamp battery saver control unit 	<ol style="list-style-type: none"> 1. Check 10A fuse (No. 61, located in fusible and fuse block). Verify battery positive voltage is present at terminals 2 and 3 of tail lamp relay. 2. Check tail lamp relay. 3. Check the following. <ol style="list-style-type: none"> a. Harness between headlamp battery saver control unit terminals 6 and 14 and tail lamp relay terminal 1 b. Harness between tail lamp relay terminal 5 and fuse block 4. Check lighting switch. 5. Check the following. <ol style="list-style-type: none"> a. Harness between lighting switch terminal 11 and headlamp battery saver control unit terminals 5 and 13 b. Harness between lighting switch terminal 5 and ground 6. Check headlamp battery saver control unit. (EL-42)
Battery saver control does not operate properly.	<ol style="list-style-type: none"> 1. RAP signal circuit 2. Driver or passenger side door switch circuit 3. Lighting switch circuit 4. Headlamp battery saver control unit 5. Smart entrance control unit 	<ol style="list-style-type: none"> 1. Check harness between headlamp battery saver control unit terminal 10 and smart entrance control unit terminal 5 for open or short circuit. 2. Check the following. <ol style="list-style-type: none"> a. Harness between smart entrance control unit and driver or passenger side door switch for open or short circuit b. Driver or passenger side door switch ground circuit c. Driver or passenger side door switch. 3. Check the following. <ol style="list-style-type: none"> a. Harness between headlamp battery saver control unit terminals 5 or 13 and lighting switch terminal 11 for open or short circuit b. Harness between lighting switch terminal 5 and ground c. Lighting switch 4. Check headlamp battery saver control unit. (EL-42) 5. Check smart entrance control unit. (EL-324)

STOP LAMP

Wiring Diagram — STOP/L —

Wiring Diagram — STOP/L —

NBEL0025

EL-STOP/L-01

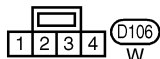
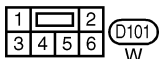
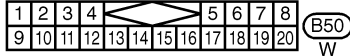
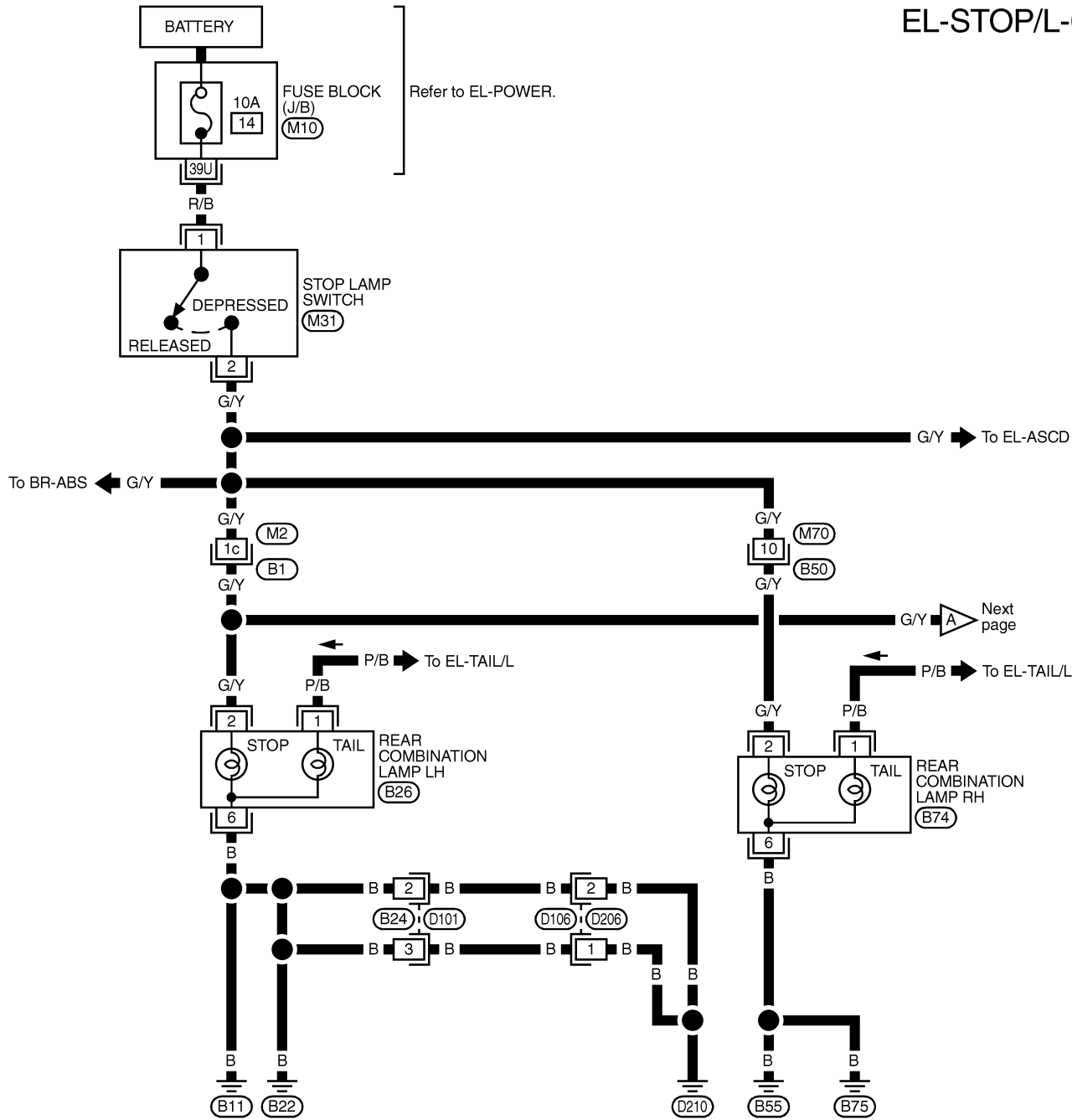

REFER TO THE FOLLOWING.

- (B1) -SUPER
- MULTIPLE JUNCTION (SMJ)
- (M10) -FUSE BLOCK-
- JUNCTION BOX (J/B)

GI

MA

EM

LC

EC

FE

AT

TF

PD

AX

SU

BR

ST

RS

BT

HA

SC

EL

IDX

MEL777L

STOP LAMP

Wiring Diagram — STOP/L — (Cont'd)

EL-STOP/L-02

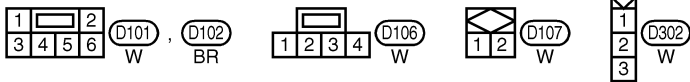
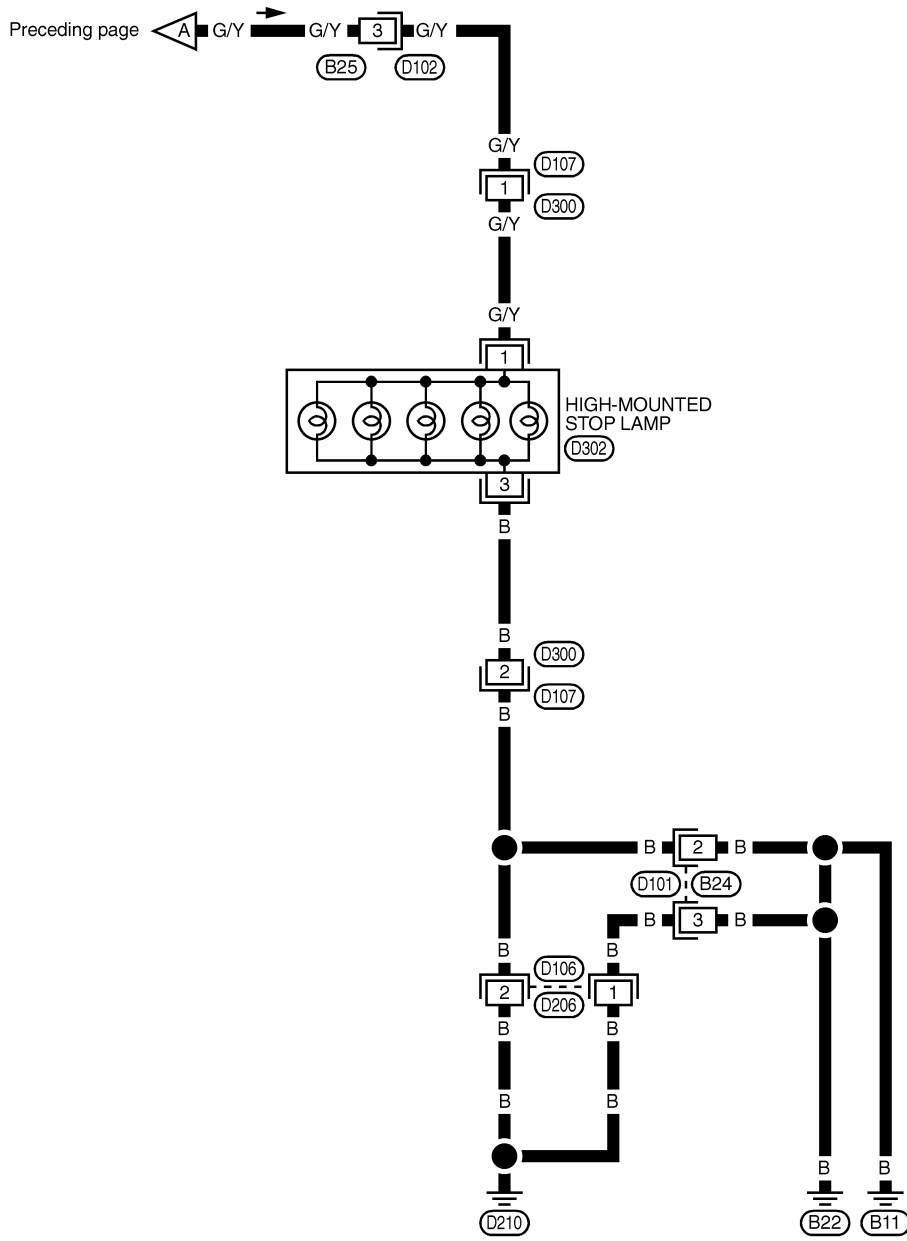

MEL262M

BACK-UP LAMP

Wiring Diagram — BACK/L —

Wiring Diagram — BACK/L —

NBEL0026

EL-BACK/L-01

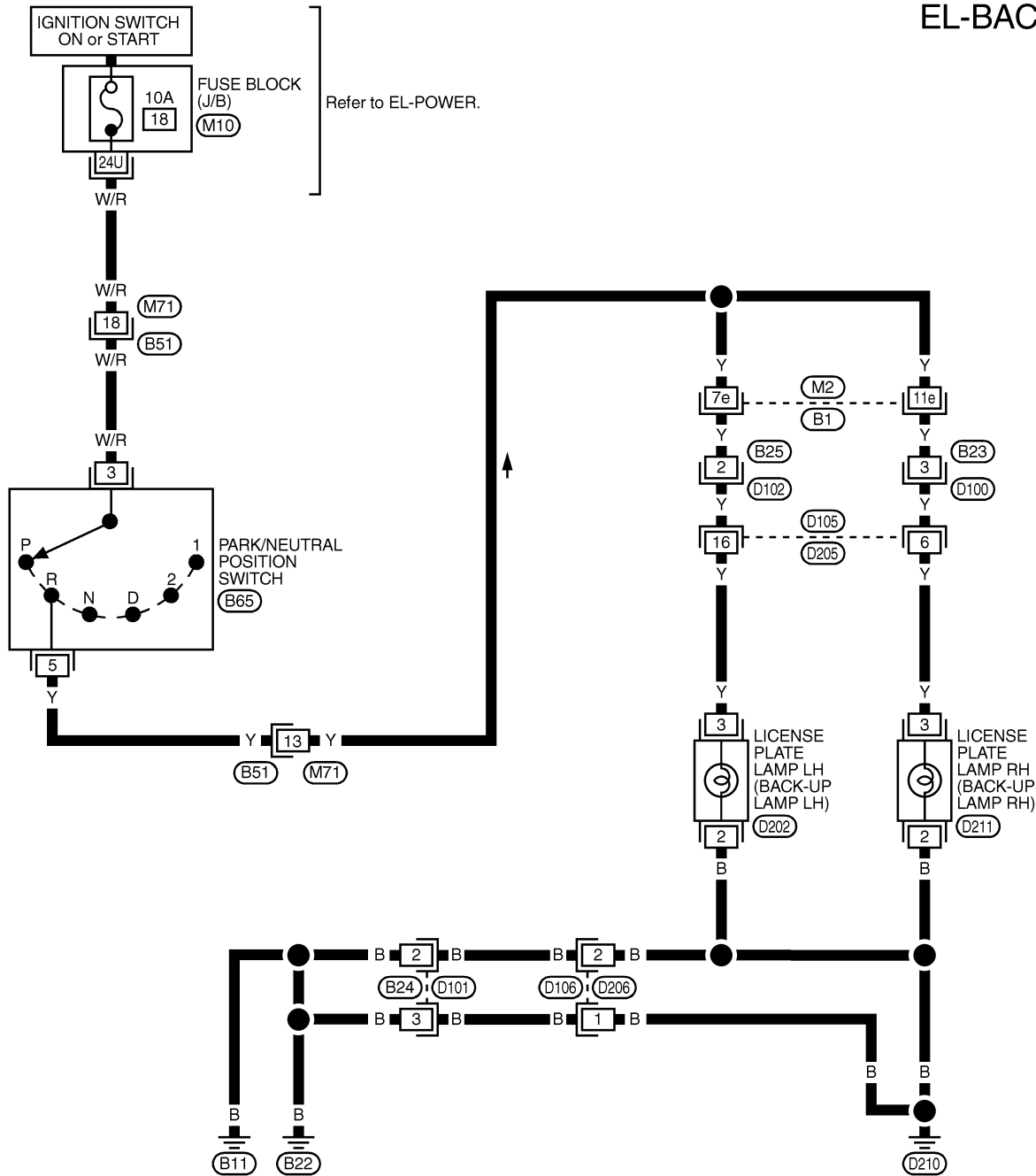

GI
MA
EM
LC
EC
FE
AT
TF
PD
AX
SU
BR
ST
RS
BT

HA
SC
EL
IDX

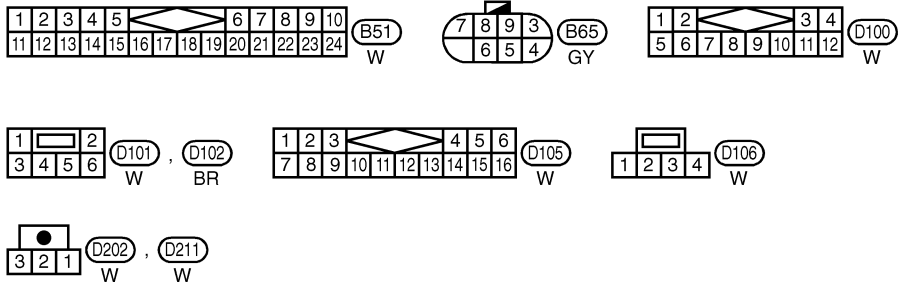

REFER TO THE FOLLOWING.
(B1) -SUPER
 MULTIPLE JUNCTION (SMJ)
(M10) -FUSE BLOCK-
 JUNCTION BOX (J/B)

FRONT FOG LAMP

System Description

System Description

NBEL0027

NBEL0027S02

OUTLINE

Power is supplied at all times

- to headlamp RH relay terminals 1 and 3
- through 15A fuse (No. 59, located in the fuse and fusible link box), and
- to headlamp battery saver control unit terminal 7
- to smart entrance control unit terminal 10
- through 7.5A fuse [No. 24, located in the fuse block (J/B)], and
- to front fog lamp relay terminal 3
- through 15A fuse (No. 53, located in the fuse and fusible link box).

When ignition switch is in ON or START position, power is supplied

- to headlamp battery saver control unit terminal 1
- through 10A fuse [No. 16, located in the fuse block (J/B)], and
- to headlamp battery saver control unit terminal 10, and
- to smart entrance control unit terminal 33
- through 7.5A fuse [No. 11, located in the fuse block (J/B)].

Ground is supplied to headlamp battery saver control unit terminals 4 and 11.

When lighting system is in 2ND position, ground is supplied

- to headlamp RH relay terminal 2 from headlamp battery saver control unit terminals 2 and 8
- through headlamp battery saver control unit terminals 3 and 9,
- through lighting switch terminal 12, and
- through body grounds E13 and E41.

Headlamp RH relay is then energized.

FRONT FOG LAMP OPERATION

NBEL0027S01

The front fog lamp switch is built into the combination switch. The lighting switch must be in the 2ND position and LOW ("B") position for front fog lamp operation.

With the front fog lamp switch in the ON position, ground is supplied

- to front fog lamp relay terminal 2
- through the front fog lamp switch, lighting switch and body grounds E13 and E41.

The front fog lamp relay is energized and power is supplied

- from front fog lamp relay terminal 5
- to terminal 1 of each front fog lamp.

Ground is supplied to terminal 3 of each front fog lamp through body grounds E13 and E41.

With power and ground supplied, the front fog lamps illuminate.

BATTERY SAVER CONTROL

NBEL0027S03

When the ignition switch is turned from ON (or START) to OFF (or ACC) positions while front fog lamps are illuminated, the RAP signal is supplied to terminal 10 of the headlamp battery saver control unit from smart entrance control unit terminal 5.

After counting 45 seconds by the RAP signal from the smart entrance control unit to headlamp battery saver control unit, the ground supply to terminal 2 of headlamp RH relay from headlamp battery saver control unit terminals 2 and 8 are terminated.

Then front fog lamps are turned to off.

Front fog lamps are turned off when driver or passenger side door is opened even if 45 seconds have not passed after the ignition switch is turned from ON (or START) to OFF (or ACC) positions while front fog lamps are illuminated.

When the lighting switch is turned from OFF to 2ND after front fog lamps are turned off by the battery saver control, ground is supplied

- to headlamp battery saver control unit terminals 5 and 13 from lighting switch terminal 11, and
- to headlamp RH relay terminal 2 from headlamp battery saver control unit terminals 2 and 8
- through headlamp battery saver control unit terminals 3 and 9, and
- through lighting switch terminal 12.

Then the front fog lamps illuminate again.

FRONT FOG LAMP

System Description (Cont'd)

NOTE:

For Trouble Diagnoses for battery saver control, refer to "HEADLAMP (FOR USA)", EL-40.

GI

MA

EM

LC

EC

FE

AT

TF

PD

AX

SU

BR

ST

RS

BT

HA

SC

EL

IDX

FRONT FOG LAMP

Wiring Diagram — F/FOG —

Wiring Diagram — F/FOG —

NBEL0028

EL-F/FOG-01

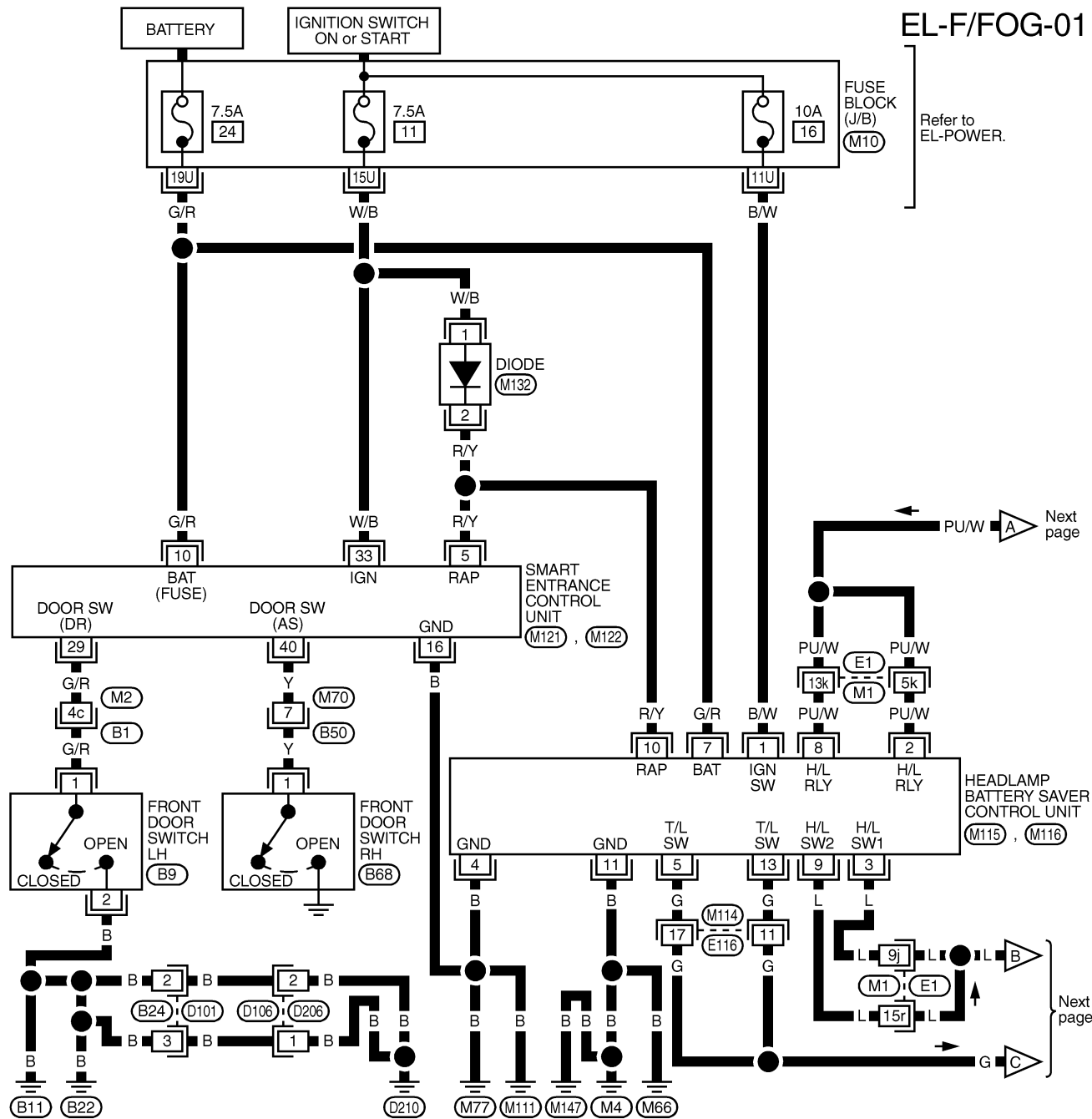

Refer to EL-POWER.

Next page

Next page

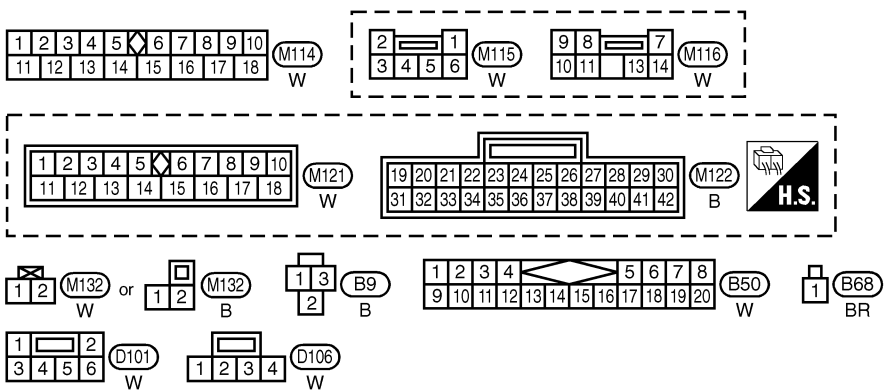

REFER TO THE FOLLOWING.

- (E1), (B1) -SUPER MULTIPLE JUNCTION (SMJ)
- (M10) -FUSE BLOCK-JUNCTION BOX (J/B)

MEL0040

FRONT FOG LAMP

Wiring Diagram — F/FOG — (Cont'd)

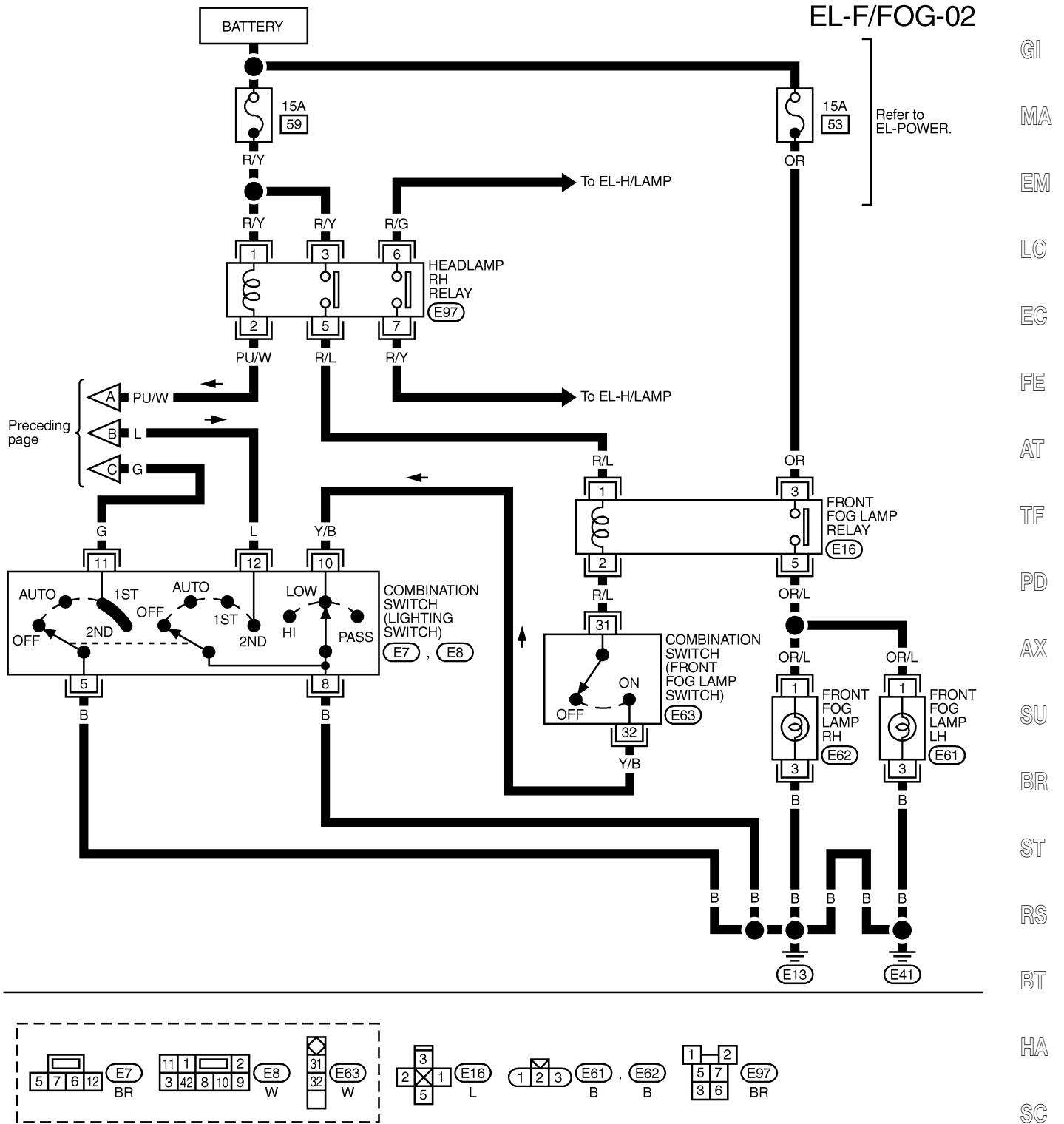

GI
MA
EM
LC
EC
FE
AT
TF
PD
AX
SU
BR
ST
RS
BT

HA
SC

EL

IDX

MEL419N

FRONT FOG LAMP

Aiming Adjustment

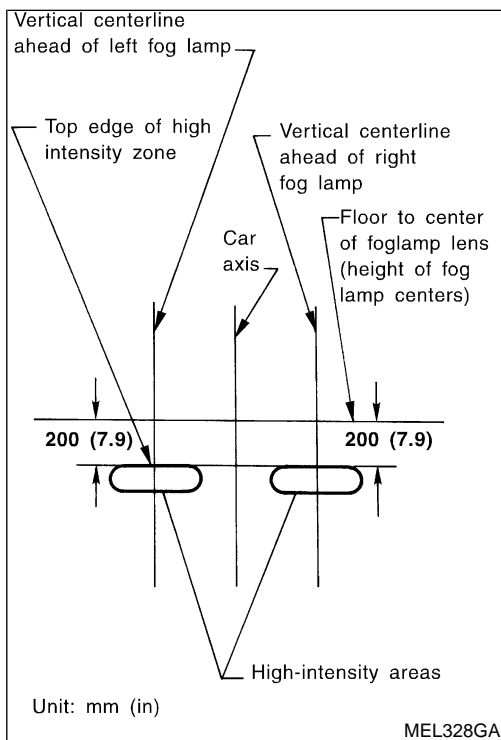
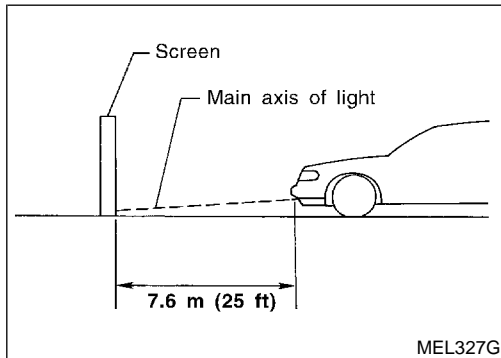
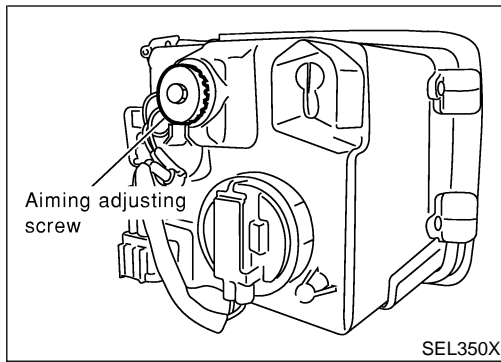

Aiming Adjustment

NBEL0029

Before performing aiming adjustment, make sure of the following.

- 1) Keep all tires inflated to correct pressure.
- 2) Place vehicle on level ground.
- 3) See that vehicle is unloaded (except for full levels of coolant, engine oil and fuel, and spare tire, jack, and tools). Have the driver or equivalent weight placed in driver's seat.

Adjust aiming in the vertical direction by turning the adjusting screw.

1. Set the distance between the screen and the center of the fog lamp lens as shown at left.
 2. Turn front fog lamps ON.
 3. Adjust front fog lamps so that the top edge of the high intensity zone is 200 mm (7.9 in) below the height of the fog lamp centers as shown at left.
- When performing adjustment, if necessary, cover the headlamps and opposite fog lamp.

System Description

NBEL0030

TURN SIGNAL OPERATION

NBEL0030S01

With the hazard switch in the OFF position and the ignition switch in the ON or START position, power is supplied

- through 7.5A fuse [No. 12, located in the fuse block (J/B)]
- to hazard switch terminal 2
- through terminal 1 of the hazard switch
- to combination flasher unit terminal 1
- through terminal 3 of the combination flasher unit
- to turn signal switch terminal 1.

Ground is supplied to combination flasher unit terminal 2 through body grounds M4, M66 and M147.

LH Turn

NBEL0030S0101

When the turn signal switch is moved to the LH position, power is supplied from turn signal switch terminal 3 to

- front fog lamp LH (turn signal) terminal 2
- combination meter terminal 25
- rear combination lamp LH terminal 5.

Ground is supplied to the front fog lamp LH (turn signal) terminal 3 through body grounds E13 and E41.

Ground is supplied to the rear combination lamp LH terminal 6 through body grounds B11, B22 and D210.

Ground is supplied to combination meter terminal 30 through body grounds M4, M66 and M147.

With power and ground supplied, the combination flasher unit controls the flashing of the LH turn signal lamps.

RH Turn

NBEL0030S0102

When the turn signal switch is moved to the RH position, power is supplied from turn signal switch terminal 2 to

- front fog lamp RH (turn signal) terminal 2
- combination meter terminal 29
- rear combination lamp RH terminal 5.

Ground is supplied to the front fog lamp RH (turn signal) terminal 3 through body grounds E13 and E41.

Ground is supplied to the rear combination lamp RH terminal 6 through body grounds B55 and B75.

Ground is supplied to combination meter terminal 30 through body grounds M4, M66 and M147.

With power and ground supplied, the combination flasher unit controls the flashing of the RH turn signal lamps.

HAZARD LAMP OPERATION

NBEL0030S02

Power is supplied at all times to hazard switch terminal 3 through:

- 15A fuse [No. 20, located in the fuse block (J/B)].

With the hazard switch in the ON position, power is supplied

- through terminal 1 of the hazard switch
- to combination flasher unit terminal 1
- through terminal 3 of the combination flasher unit
- to hazard switch terminal 4.

Ground is supplied to combination flasher unit terminal 2 through body grounds M4, M66 and M147.

Power is supplied through terminal 5 of the hazard switch to

- front fog lamp LH (turn signal) terminal 2
- combination meter terminal 25
- rear combination lamp LH terminal 5.

Power is supplied through terminal 6 of the hazard switch to

- front fog lamp RH (turn signal) terminal 2
- combination meter terminal 29
- rear combination lamp RH terminal 5.

GI

MA

EM

LC

EC

FE

AT

TF

PD

AX

SU

BR

ST

RS

BT

HA

SC

EL

IDX

TURN SIGNAL AND HAZARD WARNING LAMPS

System Description (Cont'd)

Ground is supplied to terminal 3 of each front fog lamp (turn signal) through body grounds E13 and E41.
Ground is supplied to terminal 6 of the rear combination lamp LH through body grounds B11, B22 and D210.
Ground is supplied to terminal 6 of the rear combination lamp RH through body grounds B55 and B75.
Ground is supplied to combination meter terminal 30 through body grounds M4, M66 and M147.
With power and ground supplied, the combination flasher unit controls the flashing of the hazard warning lamps.

MULTI-REMOTE CONTROL SYSTEM OPERATION

NBEL0030S03

Power is supplied at all times

- through 15A fuse [No. 20, located in the fuse block (J/B)]
- to multi-remote control relay terminals 1, 3 and 6.

Ground is supplied to multi-remote control relay terminal 2, when the multi-remote control system is triggered through the smart entrance control unit.

Refer to "MULTI-REMOTE CONTROL SYSTEM", EL-270.

The multi-remote control relay is energized.

Power is supplied through terminal 7 of the multi-remote control relay

- to front fog lamp LH (turn signal) terminal 2
- to combination meter terminal 25
- to rear combination lamp LH terminal 5.

Power is supplied through terminal 5 of the multi-remote control relay

- to front fog lamp RH (turn signal) terminal 2
- to combination meter terminal 29
- to rear combination lamp RH terminal 5.

Ground is supplied to terminal 3 of each front fog lamp (turn signal) through body grounds E13 and E41.
Ground is supplied to terminal 6 of the rear combination lamp LH through body grounds B11, B22 and D210.
Ground is supplied to terminal 6 of the rear combination lamp RH through body grounds B55 and B75.
Ground is supplied to combination meter terminal 30 through body grounds M4, M66 and M147.
With power and ground supplied, the smart entrance control unit controls the flashing of the hazard warning lamps.

TURN SIGNAL AND HAZARD WARNING LAMPS

Wiring Diagram — TURN —

Wiring Diagram — TURN —

NBEL0032

EL-TURN-01

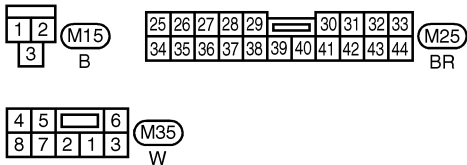
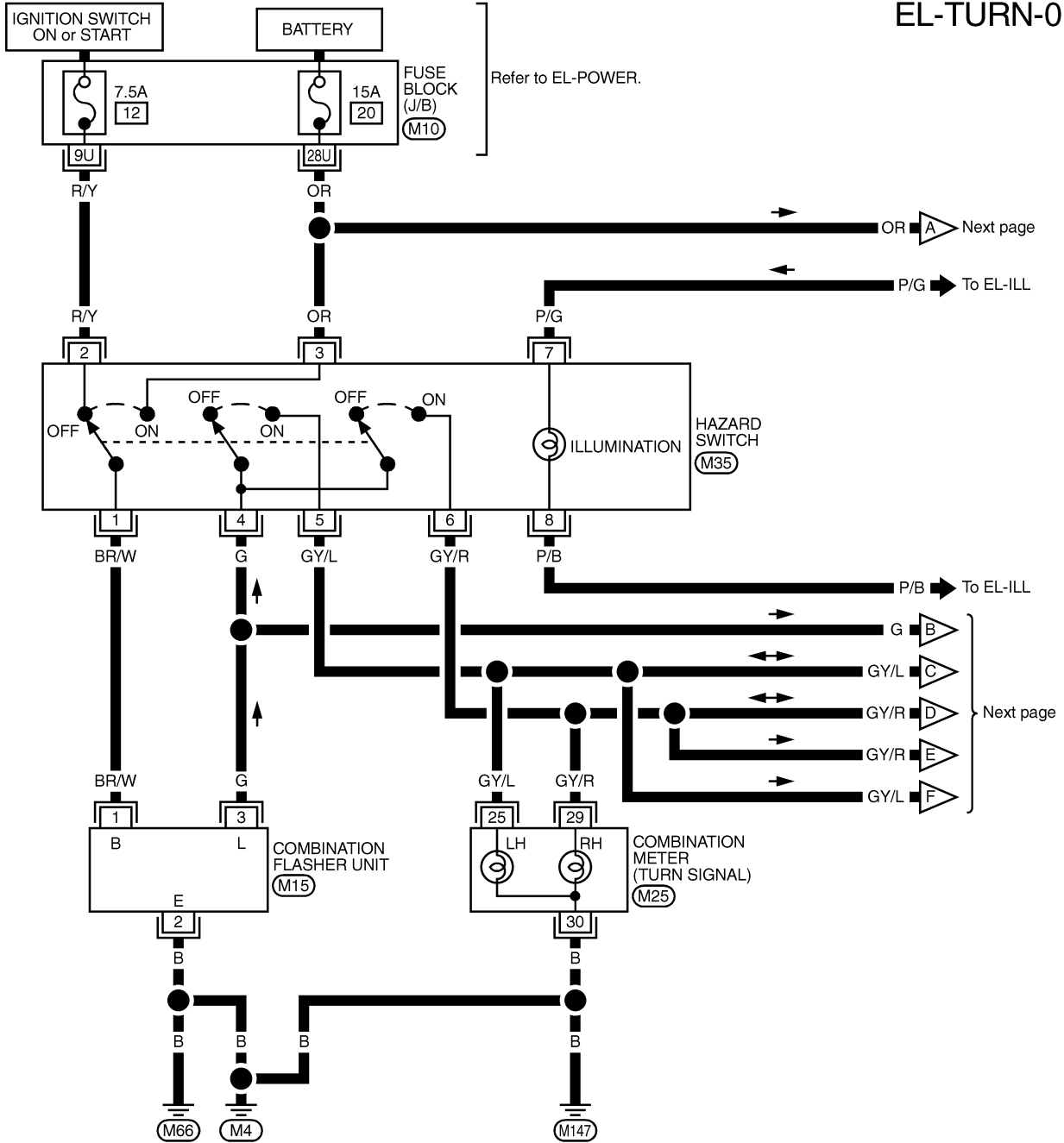

REFER TO THE FOLLOWING.
 (M10) - FUSE BLOCK-
 JUNCTION BOX (J/B)

GI

MA

EM

LC

EC

FE

AT

TF

PD

AX

SU

BR

ST

RS

BT

HA

SC

EL

IDX

MEL781L

TURN SIGNAL AND HAZARD WARNING LAMPS

Wiring Diagram — TURN — (Cont'd)

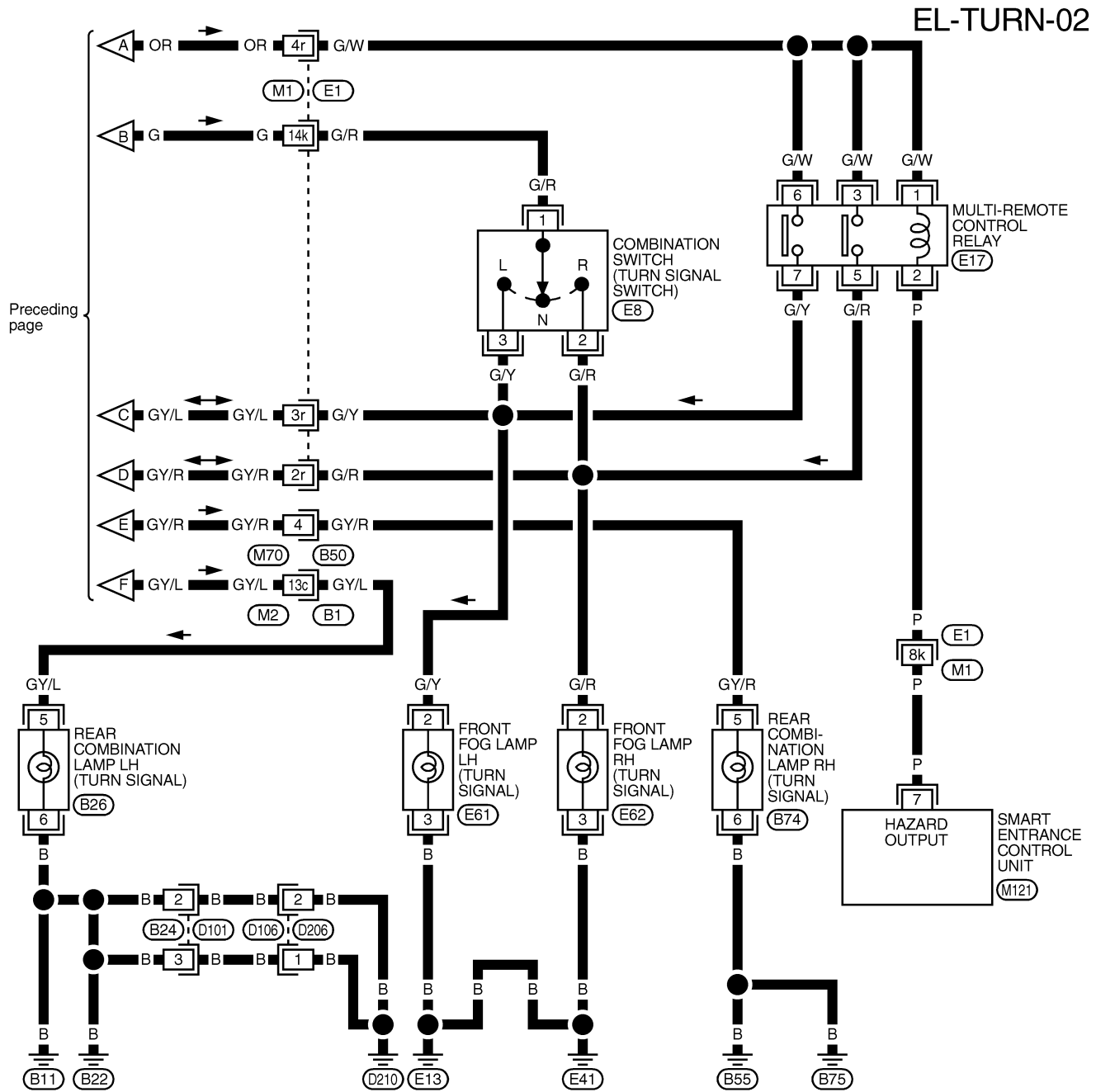

REFER TO THE FOLLOWING.
 (E1), (B1) -SUPER
 MULTIPLE JUNCTION (SMJ)

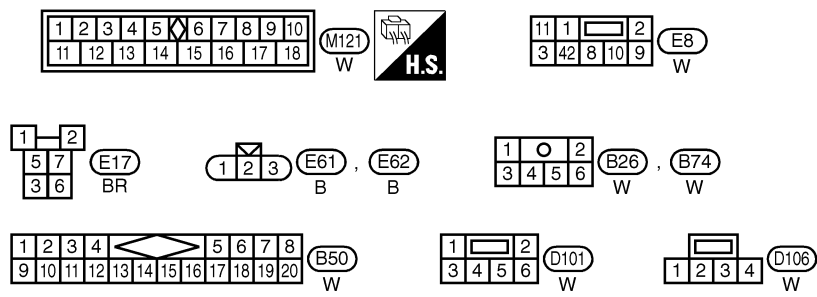

MEL782L

Trouble Diagnoses

NBEL0033

Symptom	Possible cause	Repair order	
Turn signal and hazard warning lamps do not operate.	<ol style="list-style-type: none"> 1. Hazard switch 2. Combination flasher unit 3. Open in combination flasher unit circuit 	<ol style="list-style-type: none"> 1. Check hazard switch. 2. Refer to combination flasher unit check. 3. Check wiring to combination flasher unit for open circuit. 	GI MA
Turn signal lamps do not operate but hazard warning lamps operate.	<ol style="list-style-type: none"> 1. 7.5A fuse 2. Hazard switch 3. Combination switch (turn signal) 4. Open in combination switch (turn signal) circuit 	<ol style="list-style-type: none"> 1. Check 7.5A fuse [No. 12, located in fuse block (J/B)]. Turn ignition switch ON and verify battery positive voltage is present at terminal 2 of hazard switch. 2. Check hazard switch. 3. Check combination switch (turn signal). 4. Check the wire between combination flasher unit terminal 3 and combination switch (turn signal) terminal 1 for open circuit. 	EM LC EC
Hazard warning lamps do not operate but fog lamps (turn signal) operate.	<ol style="list-style-type: none"> 1. 15A fuse 2. Hazard switch 3. Open in hazard switch circuit 	<ol style="list-style-type: none"> 1. Check 15A fuse [No. 20, located in fuse block (J/B)]. Verify battery positive voltage is present at terminal 3 of hazard switch. 2. Check hazard switch. 3. Check the wire between combination flasher unit terminal 3 and hazard switch terminal 4 for open circuit. 	FE AT TF
Front fog lamp (turn signal) LH or RH does not operate.	<ol style="list-style-type: none"> 1. Bulb 2. Grounds E13 and E41 3. Open in front fog lamp (turn signal) circuit 	<ol style="list-style-type: none"> 1. Check bulb. 2. Check grounds E13 and E41. 3. Check harness between front fog lamp (turn signal) and combination switch. 	PD
Rear combination lamp LH does not operate.	<ol style="list-style-type: none"> 1. Bulb 2. Grounds B11, B22 and D210 3. Open in rear combination lamp LH circuit 	<ol style="list-style-type: none"> 1. Check bulb. 2. Check grounds B11, B22 and D210. 3. Check harness between rear combination lamp LH and hazard switch. 	AX SU
Rear combination lamp RH does not operate.	<ol style="list-style-type: none"> 1. Bulb 2. Grounds B55 and B75 3. Open in rear combination lamp RH circuit 	<ol style="list-style-type: none"> 1. Check bulb. 2. Check grounds B55 and B75. 3. Check harness between rear combination lamp RH and hazard switch. 	BR
LH and RH turn indicators do not operate.	<ol style="list-style-type: none"> 1. Ground 	<ol style="list-style-type: none"> 1. Check grounds M4, M66 and M147. 	ST
LH or RH turn indicator does not operate.	<ol style="list-style-type: none"> 1. Bulb 2. Open in turn indicator circuit 	<ol style="list-style-type: none"> 1. Check bulb in combination meter. 2. Check harness between combination meter and hazard switch. 	RS

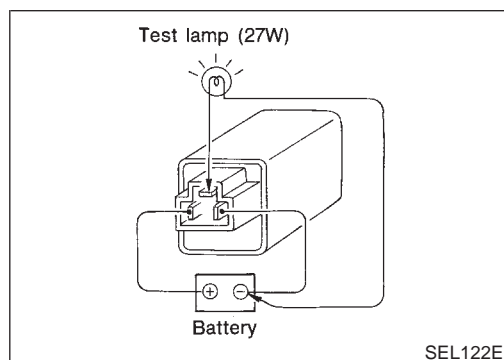

Electrical Components Inspection COMBINATION FLASHER UNIT CHECK

NBEL0034

NBEL0034S01

- Before checking, ensure that bulbs meet specifications.
- Connect a battery and test lamp to the combination flasher unit, as shown. Combination flasher unit is properly functioning if it blinks when power is supplied to the circuit.

EL

IDX

ILLUMINATION

System Description

System Description

NBEL0035

The illumination lamp operation is controlled by the lighting switch which is built into the combination switch and headlamp battery saver control unit. The battery saver system is controlled by the headlamp battery saver control unit and smart entrance control unit.

Power is supplied at all times

- to tail lamp relay terminals 2 and 3
- through 10A fuse (No. 61, located in the fuse and fusible link box), and
- to headlamp battery saver control unit terminal 7, and
- to smart entrance control unit terminal 10
- through 7.5A fuse [No. 24, located in the fuse block (J/B)].

When ignition switch is in ON or START position, power is supplied

- to headlamp battery saver control unit terminal 1
- through 10A fuse [No. 16, located in the fuse block (J/B)], and
- to headlamp battery saver control unit terminal 10, and
- to smart entrance control unit terminal 33
- through 7.5A fuse [No. 11, located in the fuse block (J/B)].

Ground is supplied to headlamp battery saver control unit terminals 4 and 11.

LIGHTING OPERATION BY LIGHTING SWITCH

NBEL0035S01

When lighting switch is 1ST (or 2ND) position, ground is supplied

- to tail lamp relay terminal 1 from headlamp battery saver control unit terminals 6 and 14
- through headlamp battery saver control unit terminals 5 and 13, and
- through body grounds E13 and E41.

Tail lamp relay is then energized and illumination lamps illuminate.

The lighting switch must be in the 1ST or 2ND position for illumination.

LIGHTING OPERATION BY AUTO LIGHT CONTROL SYSTEM

NBEL0035S03

When auto light operation is operated, ground is supplied

- to tail lamp relay terminal 1 from headlamp battery saver control unit terminals 6 and 14
- through headlamp battery saver control unit terminals 5 and 13, and
- through auto light control unit terminal 7.

Tail lamp relay is then energized and the illumination lamps illuminate.

The illumination control switch that controls the amount of current to the illumination system. As the amount of current increases, the illumination becomes brighter.

The following chart shows the power and ground connector terminals for the components included in the illumination system.

Component	Connector No.	Power terminal	Ground terminal
Illumination control switch	M19	1	3
4WD shift switch	M141	7	8
Ashtray	M54	1	2
A/T indicator	B59	3	4
Cigarette lighter	M57	3	4
Audio unit	M48	8	7
Compass and thermometer	R4	5	2
Hazard switch	M35	7	8
Rear window defogger switch	M36	5	6
Headlamp aiming switch	M16	3	4
Power window main switch	D6	16	18
Front power window switch RH	D36	10	17

ILLUMINATION

System Description (Cont'd)

Component	Connector No.	Power terminal	Ground terminal	
IVCS switch	R10	2	12	GI
Display & NAVI control unit	M117, M118	8	24	
A/C auto amp.	M102	24	25	MA
Clock	M39	3	4	
Globe box lamp	M30	1	2	EM

The ground for all of the components except for compass, glove box lamp and ashtray are controlled through terminals 2 and 3 of the illumination control switch and body grounds M77 and M111.

BATTERY SAVER CONTROL

When the ignition switch is turned from ON (or START) to OFF (or ACC) positions while illumination lamps are illuminated, the RAP signal is supplied to terminal 10 of the headlamp battery saver control unit from smart entrance control unit terminal 5.

After counting 45 seconds by the RAP signal from the smart entrance control unit to headlamp battery saver control unit, the ground supply to terminal 1 of the tail lamp relay from headlamp battery saver control unit terminals 6 and 14 is terminated.

Then illumination lamps are turned off.

Illumination lamps are turned off when driver or passenger side door is opened even if 45 seconds have not passed after the ignition switch is turned from ON (or START) to OFF (or ACC) positions while illumination lamps are illuminated.

When the lighting switch is turned from OFF to 1ST (or 2ND) after illumination lamps are turned off by the battery saver control, ground is supplied

- to headlamp battery saver control unit terminals 5 and 13 from lighting switch terminal 11, and
- to tail lamp relay terminal 1 from headlamp battery saver control unit terminals 6 and 14.

Then illumination lamps illuminate again.

NOTE:

For Trouble Diagnoses for battery saver control, refer to "PARKING, LICENSE AND TAIL LAMPS" (EL-66).

GI
MA
EM
LC
EC
FE
AT
TF
PD
AX
SU
BR
ST
RS
BT
HA
SC
EL
IDX

ILLUMINATION

Schematic

NBEL0036

Schematic

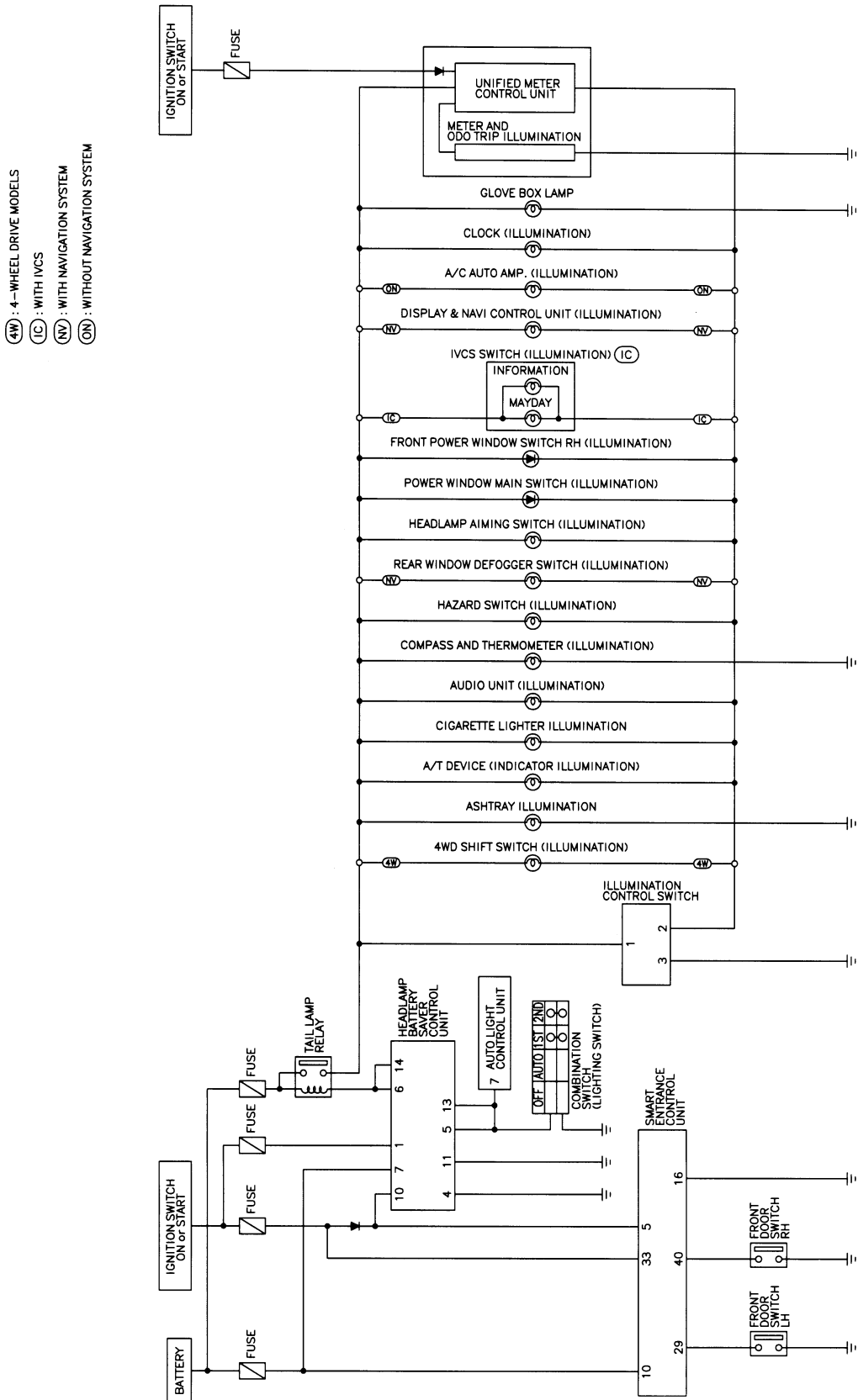

MEL783L

ILLUMINATION

Wiring Diagram — ILL —

Wiring Diagram — ILL —

NBEL0037

EL-ILL-01

GI
MA
EM
LC
EC
FE
AT
TF
PD
AX
SU
BR
ST
RS
BT
HA
SC
EL
IDX

Refer to EL-POWER.

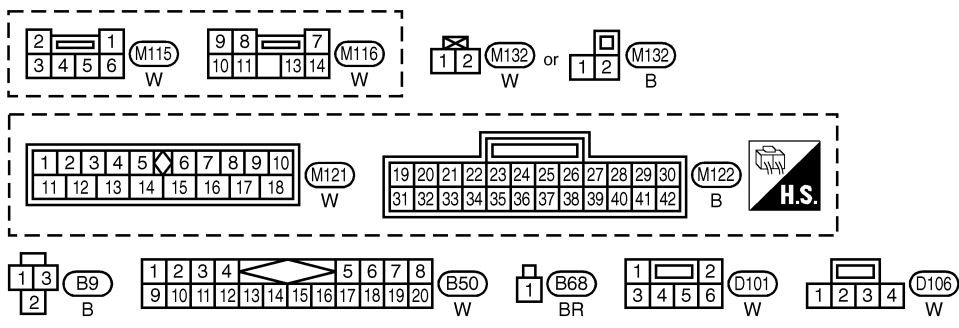
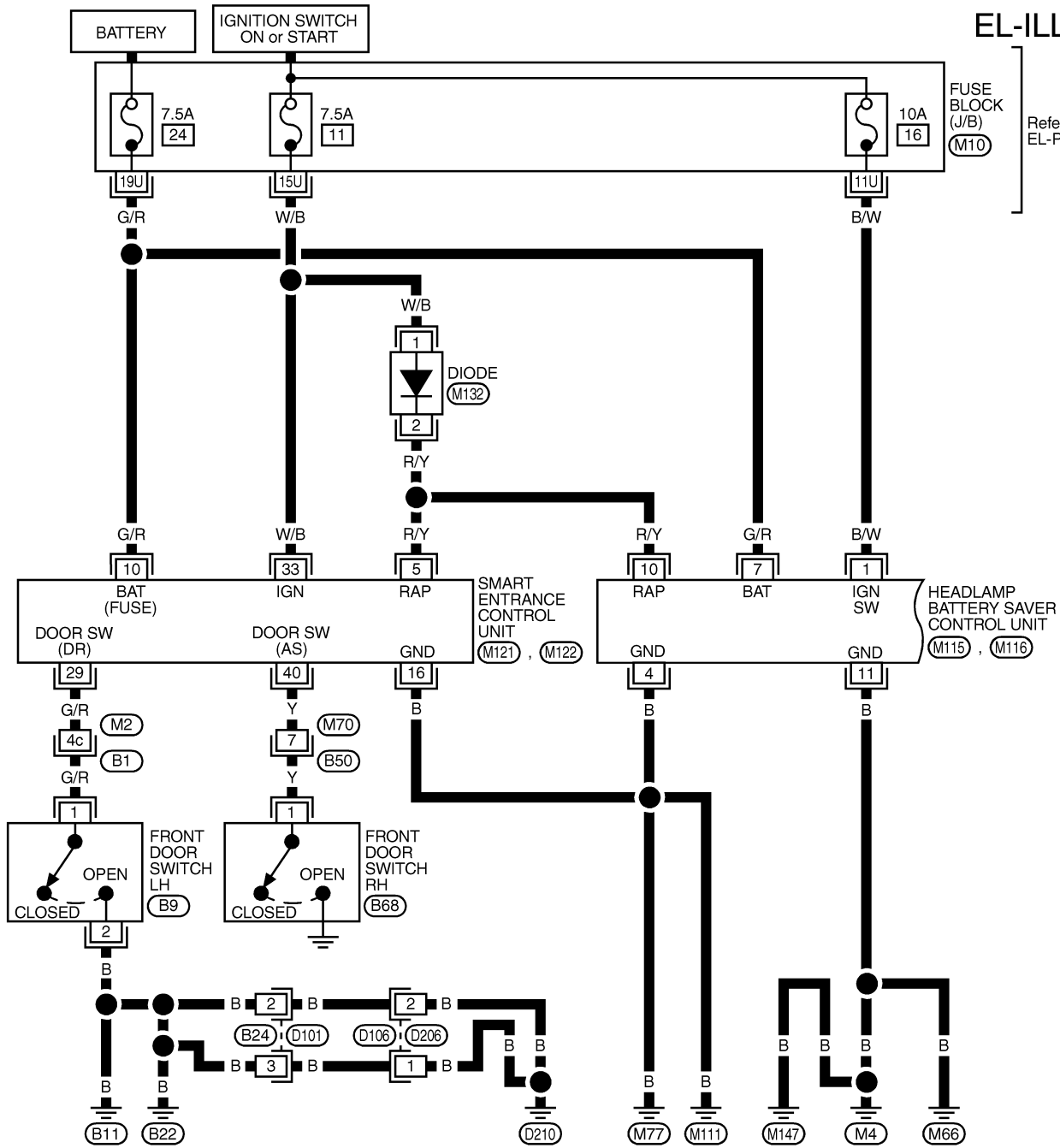

REFER TO THE FOLLOWING.

- (B1) -SUPER
- MULTIPLE JUNCTION (SMJ)
- (M10) -FUSE BLOCK-
- JUNCTION BOX (J/B)

MEL0050

ILLUMINATION

Wiring Diagram — ILL — (Cont'd)

EL-ILL-02

4W : 4-WHEEL DRIVE MODELS

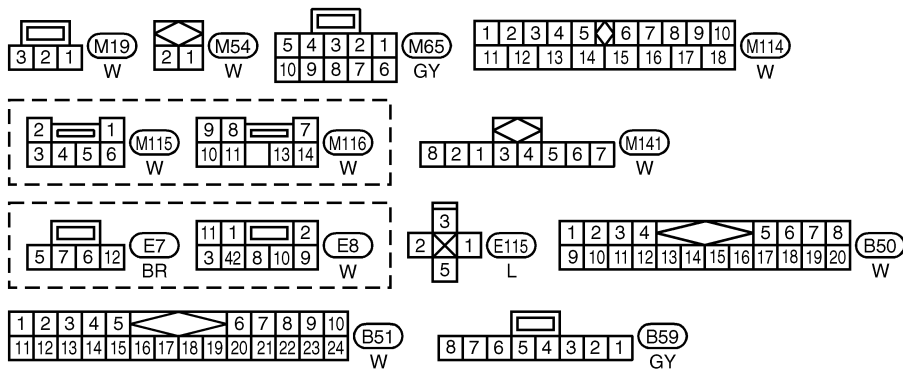
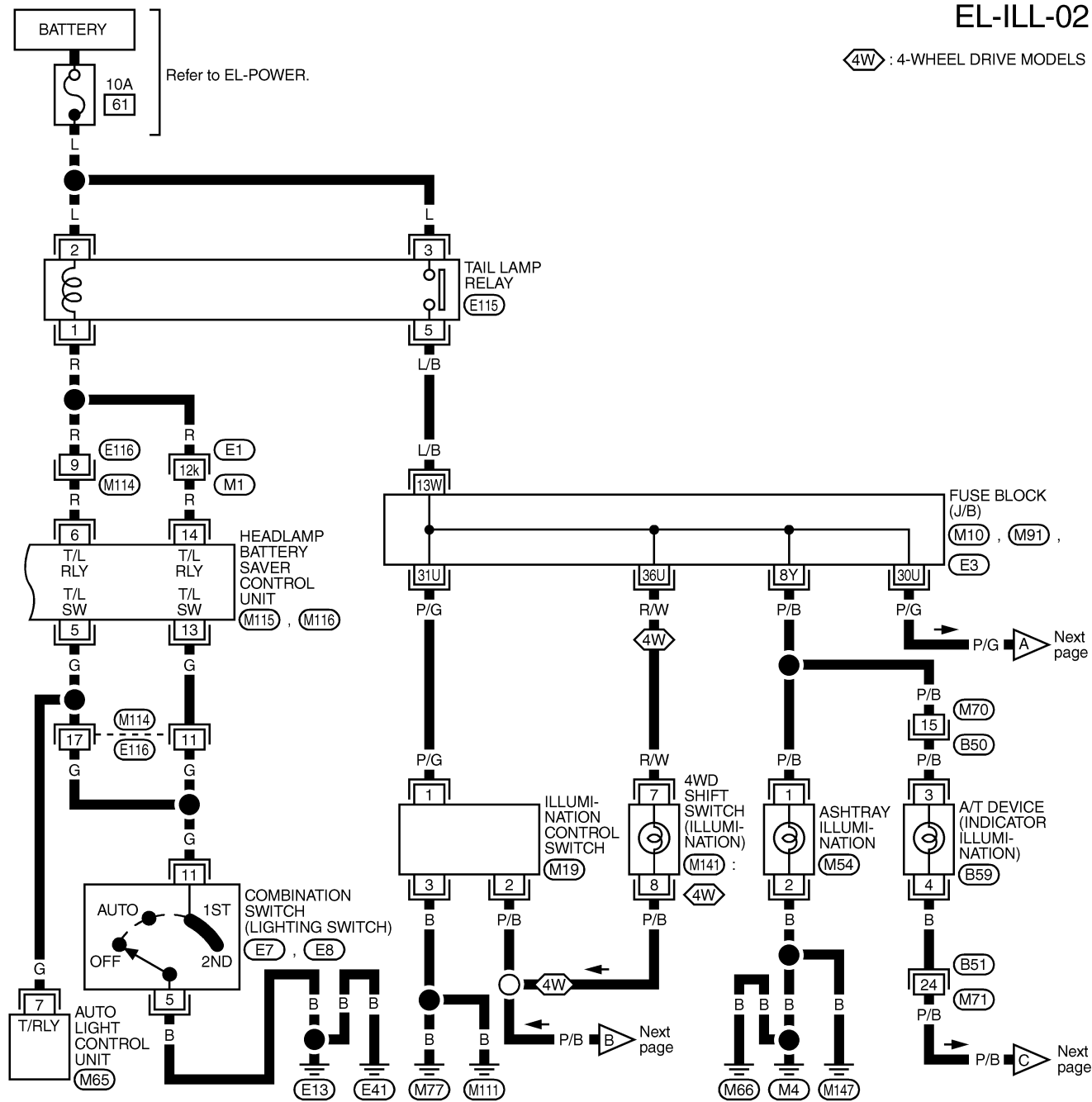

REFER TO THE FOLLOWING.

- (E1) -SUPER
- MULTIPLE JUNCTION (SMJ)
- (M10) , (M91) , (E3)
- FUSE BLOCK-
- JUNCTION BOX (J/B)

ILLUMINATION

Wiring Diagram — ILL — (Cont'd)

EL-ILL-03

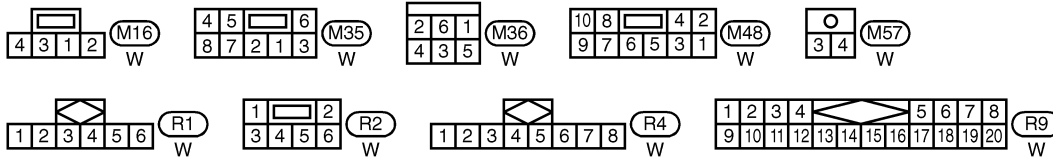
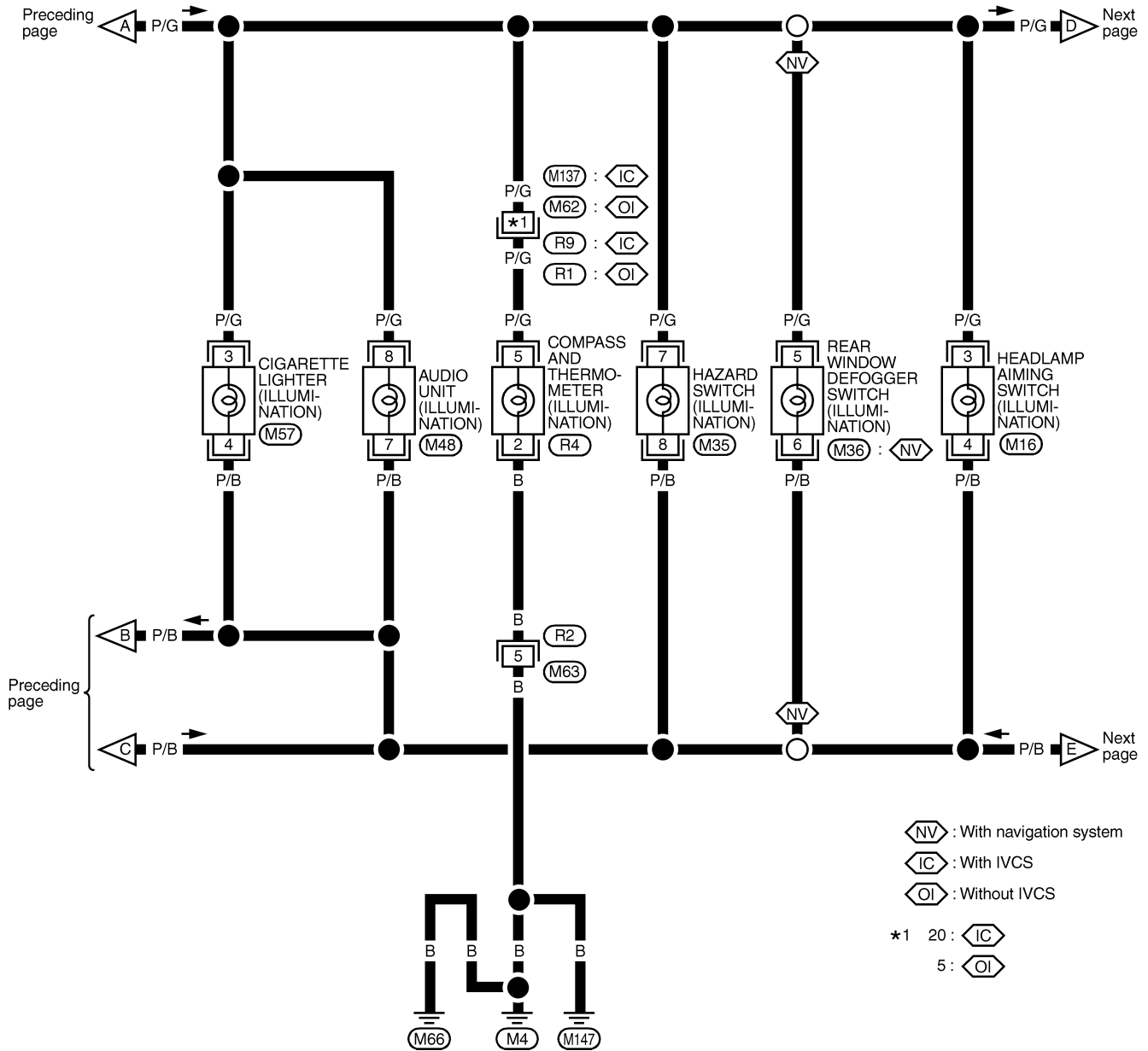

GI
MA
EM
LC
EC
FE
AT
TF
PD
AX
SU
BR
ST
RS
BT
HA
SC
EL
IDX

MEL786L

ILLUMINATION

Wiring Diagram — ILL — (Cont'd)

EL-ILL-04

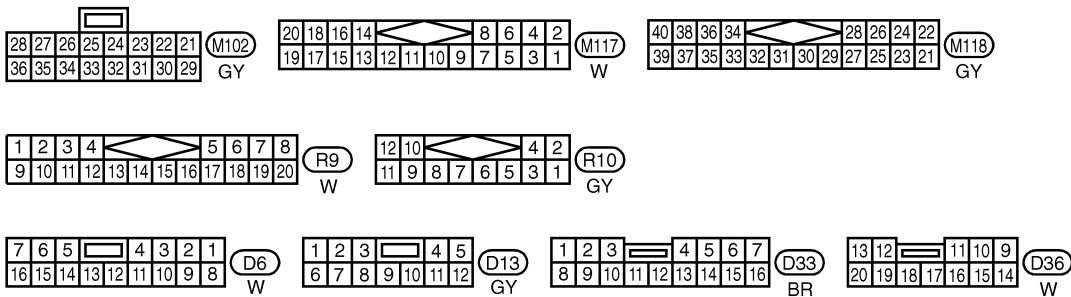
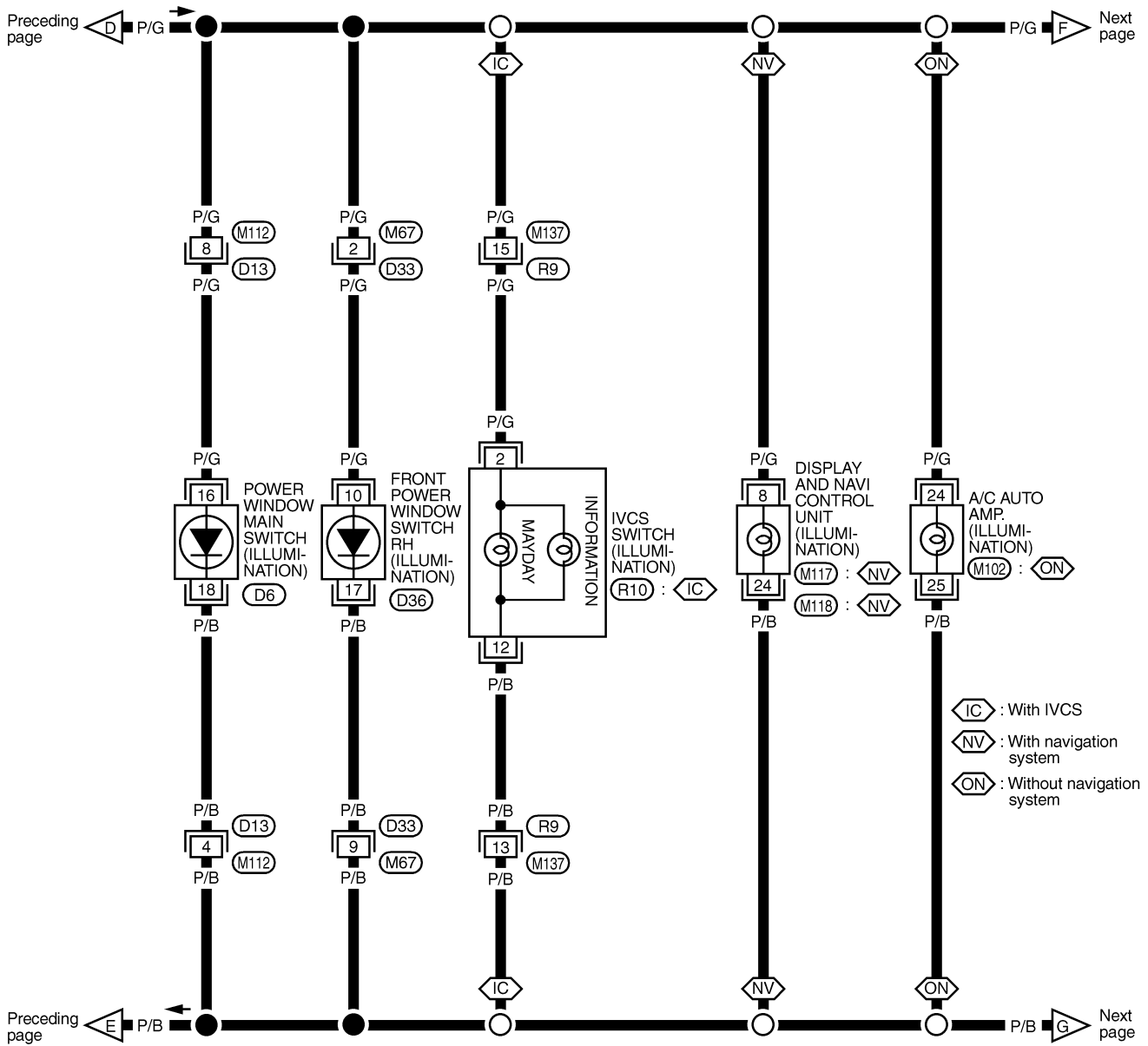

MEL787L

ILLUMINATION

Wiring Diagram — ILL — (Cont'd)

EL-ILL-05

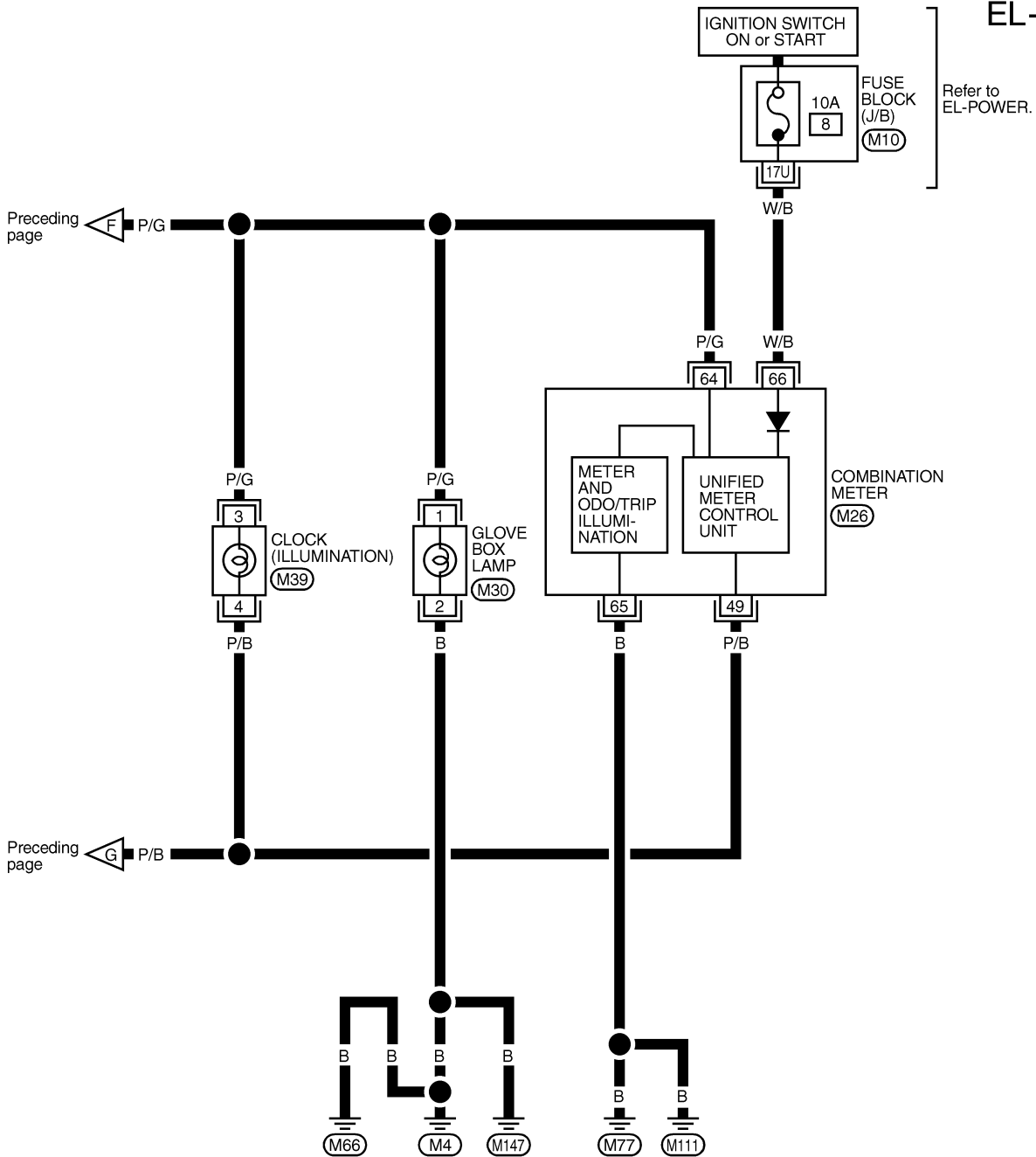

GI
MA
EM
LC
EC
FE
AT
TF
PD
AX
SU
BR
ST
RS
BT
HA
SC
EL
IDX



REFER TO THE FOLLOWING.
 M10 - FUSE BLOCK-JUNCTION BOX (J/B)

MEL788L

INTERIOR, SPOT, VANITY MIRROR AND LUGGAGE ROOM LAMPS

System Description

System Description

NBEL0038

NBEL0038S06

POWER SUPPLY AND GROUND

Power is supplied at all times:

- through 7.5A fuse [No. 24, located in the fuse block (J/B)]
- to key switch terminal 2 and
- to smart entrance control unit terminal 10.

When the key is removed from ignition key cylinder, power is interrupted:

- through key switch terminal 1
- to smart entrance control unit terminal 32.

With the ignition key switch in the ON or START position, power is supplied:

- through 7.5A fuse [No. 11, located in the fuse block (J/B)]
- to smart entrance control unit terminal 33.

Ground is supplied:

- to smart entrance control unit terminal 16
- through body grounds terminals M77 and M111.

When the front driver side door is opened, ground is supplied:

- through body grounds B11, B22 and D210
- to front door switch (LH) terminal 2
- from front door switch (LH) terminal 1
- to smart entrance control unit terminal 29.

When the front passenger side door is opened, ground is supplied:

- through case ground of front door switch (RH)
- from front door switch (RH) terminal 1
- to smart entrance control unit terminal 40.

When any other door (except front door) is opened, ground is supplied to smart entrance control unit terminal 28 in the same manner as the front door switch (front passenger side).

When the front driver side door is unlocked, the smart entrance control unit receives a ground signal:

- through body grounds terminals M77 and M111
- to front door lock actuator (driver side unlock sensor) terminal 2
- from front door lock actuator (driver side unlock sensor) terminal 4
- to smart entrance control unit terminal 36.

When a signal, or combination of signals is received by the smart entrance control unit, ground is supplied:

- through smart entrance control unit terminal 8
- to interior lamp terminal 2.

With power and ground supplied, the interior lamp illuminates.

SWITCH OPERATION

When interior lamp switch is ON, ground is supplied:

- through case grounds of interior lamp
- to interior lamp.

And power is supplied:

- to interior lamp terminal 1
- from smart entrance control unit terminal 17.

When spot lamp (LH and/or RH) is ON, ground is supplied:

- through body grounds M4, M66 and M147
- to spot lamp terminal 2.

And power is supplied:

- to spot lamp terminal 1
- from smart entrance control unit terminal 17.

When vanity mirror illumination (LH and/or RH) is ON, ground is supplied:

- through body grounds M4, M66 and M147
- to vanity mirror illuminations (LH and RH) terminals 2.

NBEL0038S07

INTERIOR, SPOT, VANITY MIRROR AND LUGGAGE ROOM LAMPS

System Description (Cont'd)

And power is supplied:

- to vanity mirror illuminations (LH and RH) terminals 1
- from smart entrance control unit terminal 17.

GI

With power and ground supplied, interior lamps turn ON.

INTERIOR LAMP TIMER OPERATION

MA

When interior lamp switch is in the "DOOR" position, the smart entrance control unit keeps the interior lamp illuminated for about 30 seconds when:

NBEL0038S08

- unlock signal is supplied from driver's door unlock sensor while all doors are closed and key is removed from ignition key cylinder
- unlock signal is supplied from multi-remote controller while all doors are closed and driver's door is locked
- key is removed from ignition key cylinder while all doors are closed
- driver's door is opened and then closed while key is removed from the ignition key cylinder. (However, if the driver's door is closed with the key inserted in the ignition key cylinder after the driver's door is opened with the key removed, the timer is operated.)

EM

LC

EC

The timer is canceled when:

- driver's door is locked,
- driver's door is opened, or
- ignition switch is turned ON.

FE

AT

ON-OFF CONTROL

When the driver side door, front passenger door, rear LH, RH door or back door is opened, the interior room lamp turns on while the interior room lamp switch is in the "DOOR" position.

NBEL0038S09

TF

BATTERY SAVER

The lamp turns off automatically when interior lamp, luggage room lamp, spot lamp and/or vanity mirror illumination is illuminated with the ignition key is in OFF position, if the lamp remains lit by the door switch open signal or if the lamp switch is in ON position for more than 10 minutes.

NBEL0038S10

PD

After lamps turn OFF by the battery saver system, the lamps illuminate again when:

- driver's door is locked or unlocked,
- door is opened or closed,
- key is inserted or removed in ignition key cylinder.

AX

SU

BR

ST

RS

BT

HA

SC

EL

IDX

INTERIOR, SPOT, VANITY MIRROR AND LUGGAGE ROOM LAMPS

Schematic

Schematic

NBEL0158

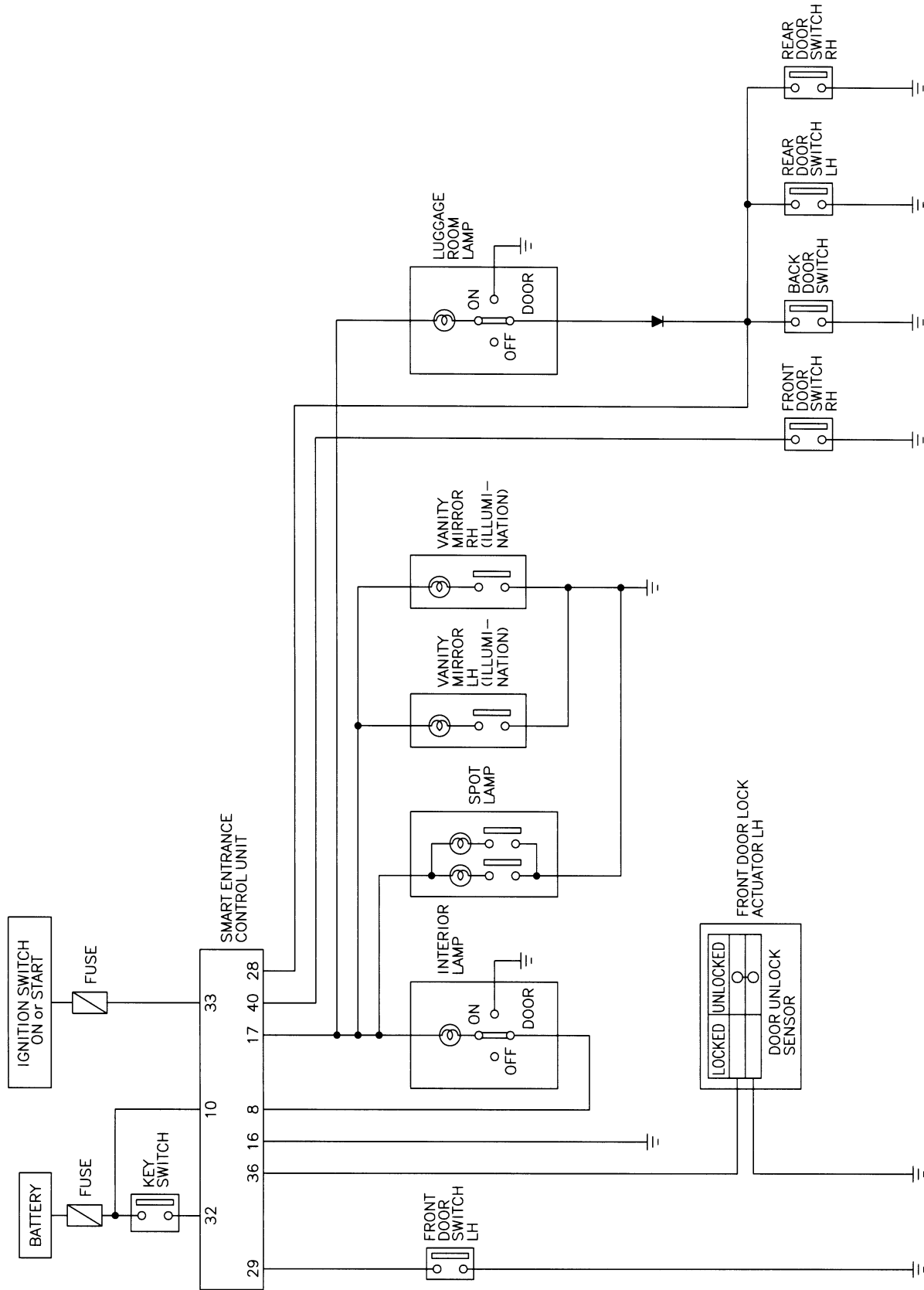

MEL209M

INTERIOR, SPOT, VANITY MIRROR AND LUGGAGE ROOM LAMPS

Wiring Diagram — INT/L —

Wiring Diagram — INT/L —

NBEL0040

EL-INT/L-01

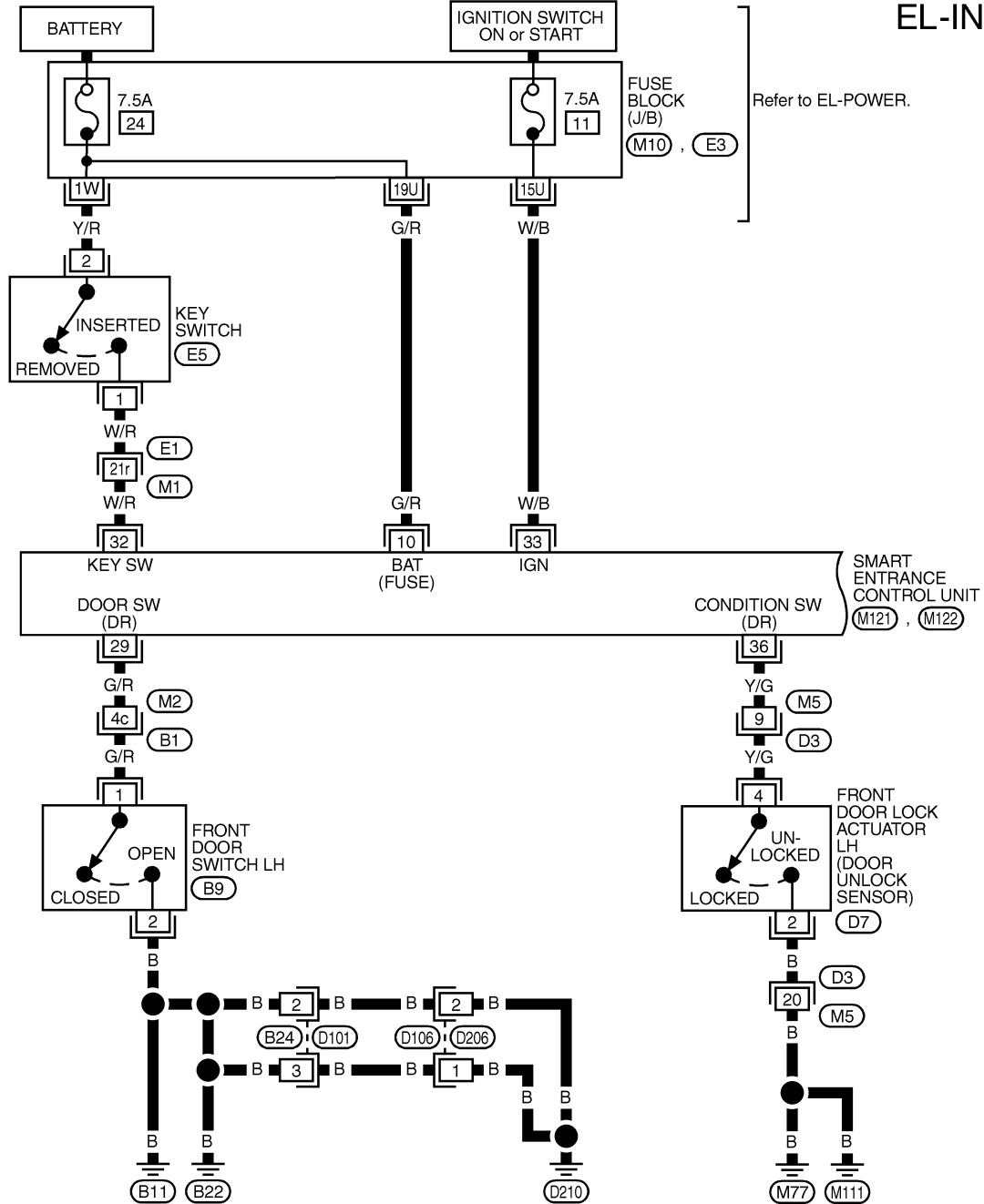

GI
MA
EM
LC
EC
FE
AT
TF
PD
AX
SU
BR
ST
RS
BT
HA
SC
EL
IDX

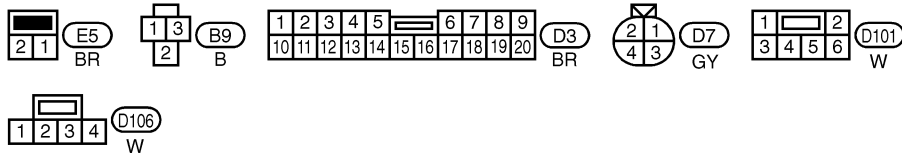
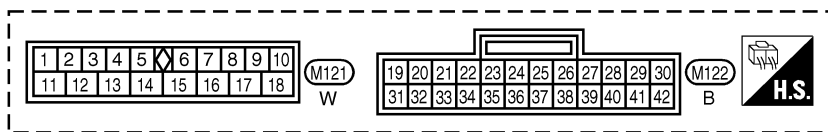

REFER TO THE FOLLOWING.

(E1), (B1) -SUPER
MULTIPLE JUNCTION (SMJ)
(M10), (E3) -FUSE BLOCK-
JUNCTION BOX (J/B)

MEL789L

INTERIOR, SPOT, VANITY MIRROR AND LUGGAGE ROOM LAMPS

Wiring Diagram — INT/L — (Cont'd)

EL-INT/L-02

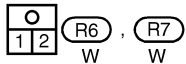
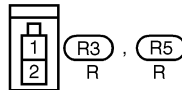
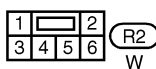
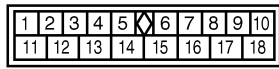
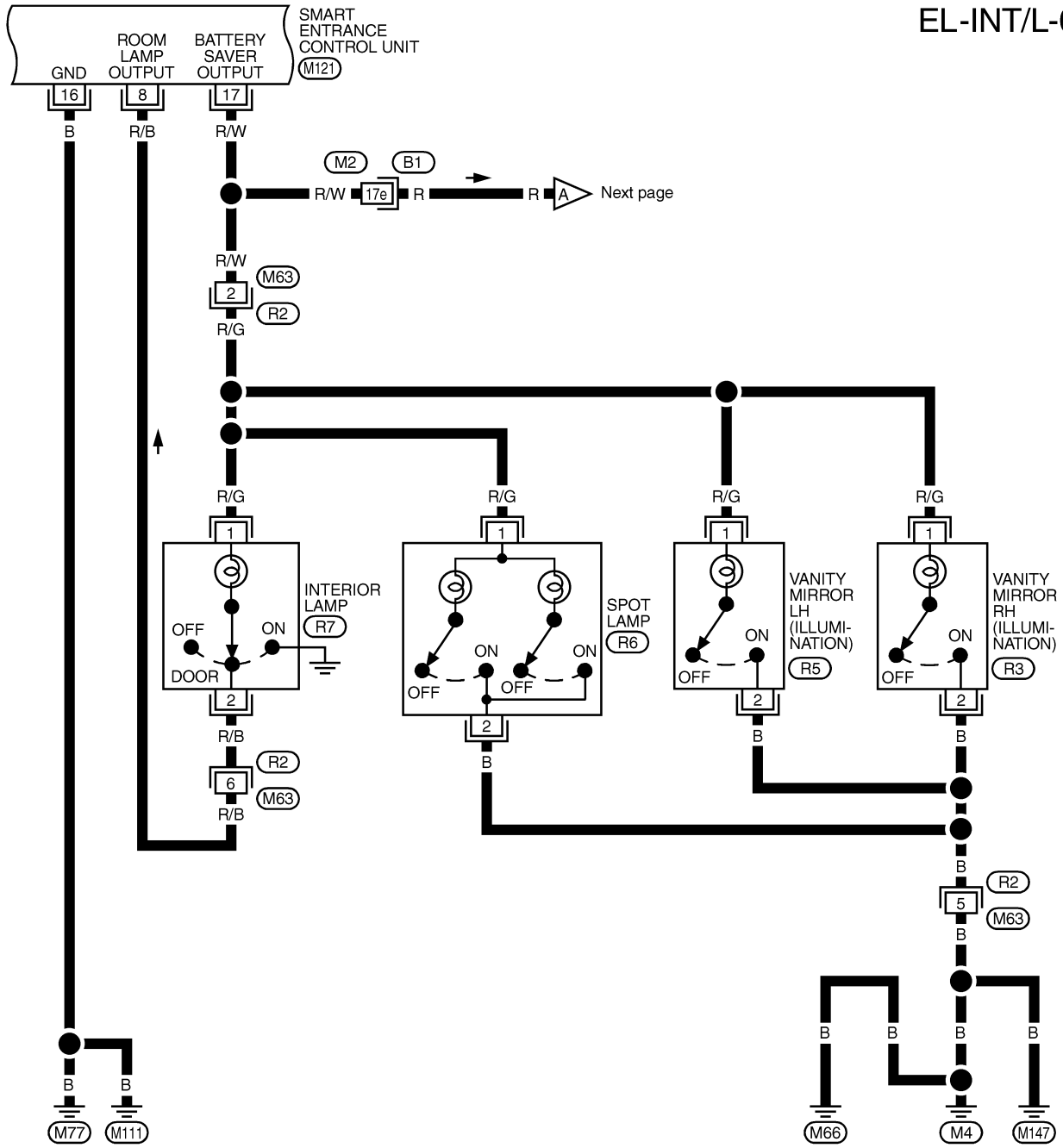

REFER TO THE FOLLOWING.

(B1) -SUPER
MULTIPLE JUNCTION (SMJ)

MEL790L

INTERIOR, SPOT, VANITY MIRROR AND LUGGAGE ROOM LAMPS

Wiring Diagram — INT/L — (Cont'd)

EL-INT/L-03

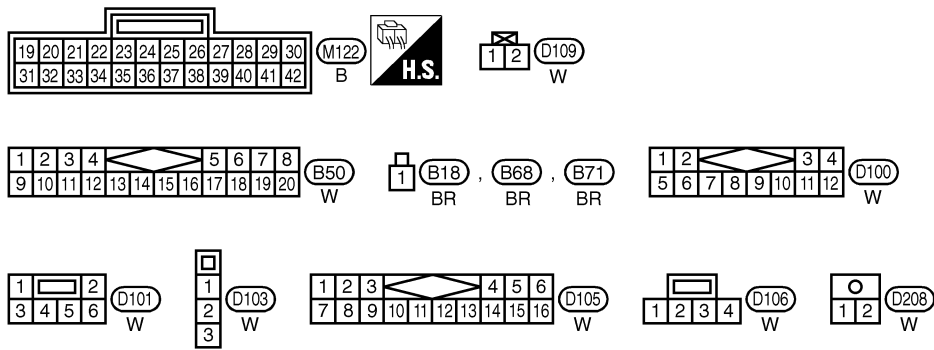
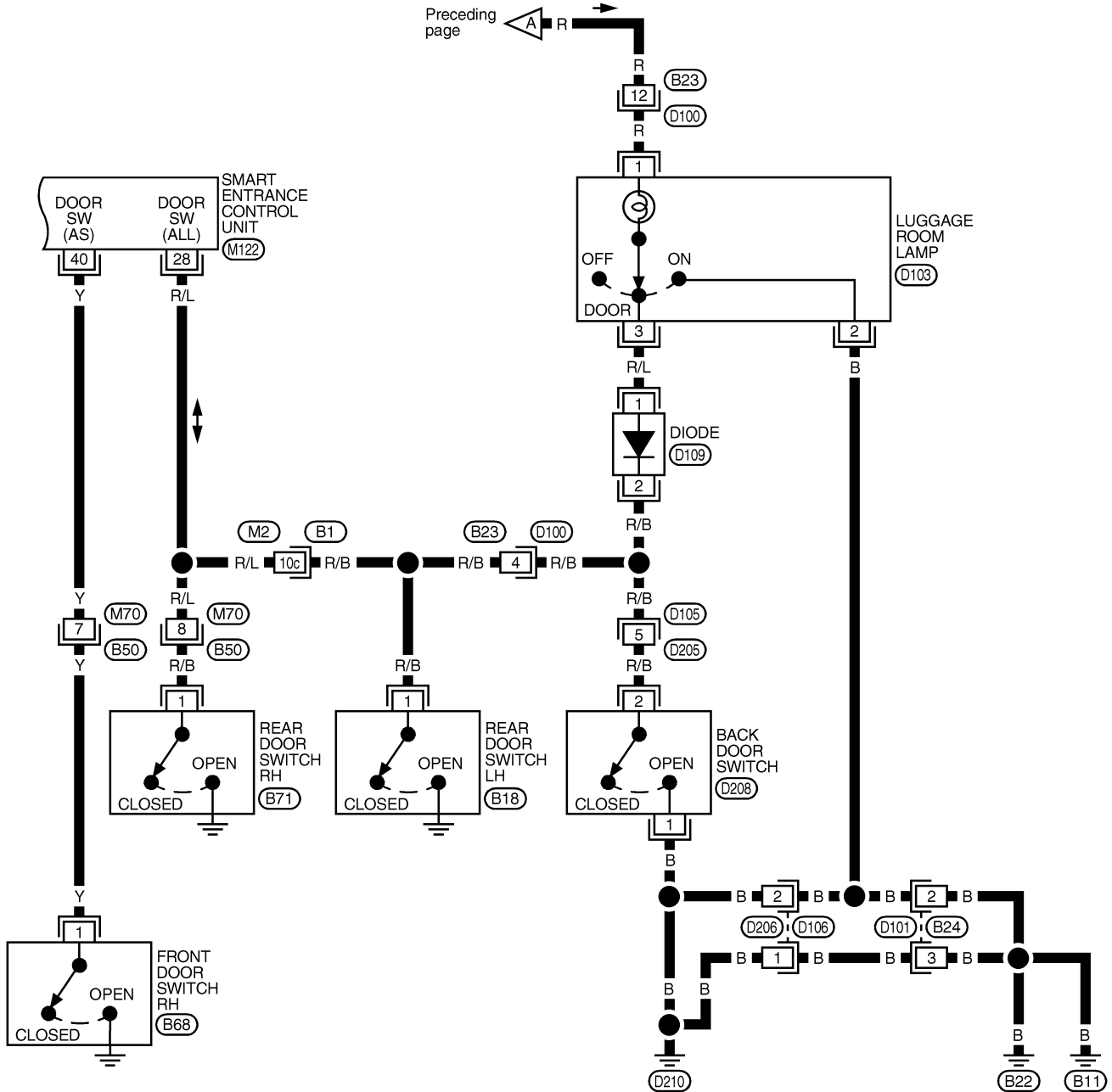

REFER TO THE FOLLOWING.
(B1) -SUPER
 MULTIPLE JUNCTION (SMJ)

GI
 MA
 EM
 LC
 EC
 FE
 AT
 TF
 PD
 AX
 SU
 BR
 ST
 RS
 BT
 HA
 SC
EL
 IDX

MEL791L

METERS AND GAUGES

Component Parts and Harness Connector Location

Component Parts and Harness Connector Location

NBEL0041

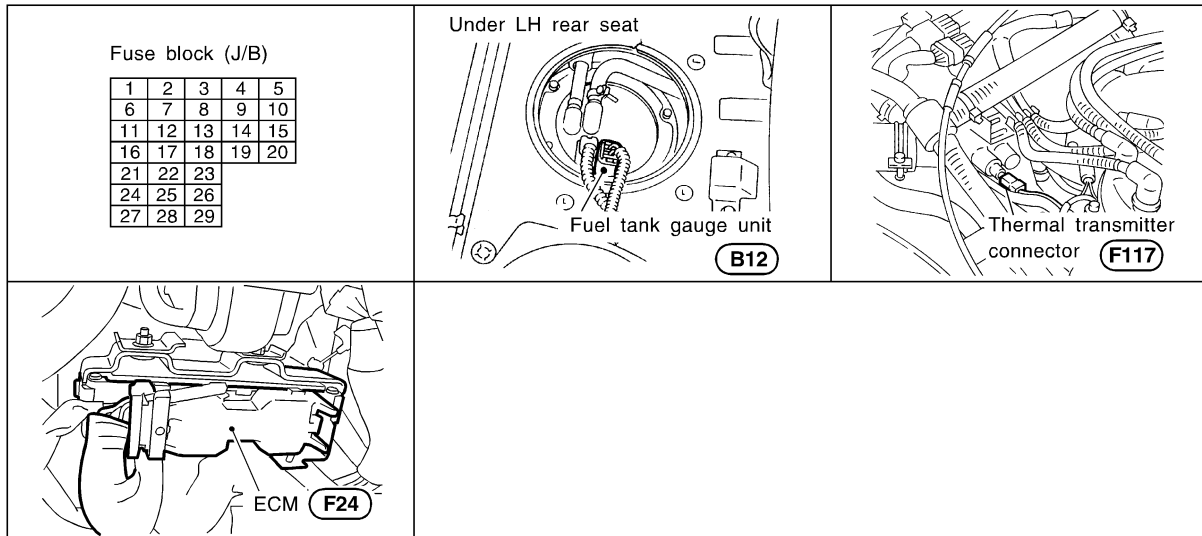

SEL351X

System Description

NBEL0042

UNIFIED CONTROL METER

NBEL0042S06

- Speedometer, odo/trip meter, tachometer, fuel gauge and water temperature gauge are controlled totally by control unit.
- Digital meter is adopted for odo/trip meter.*
*The record of the odo meter is kept even if the battery cable is disconnected. The record of the trip meter is erased when the battery cable is disconnected.
- Odo/trip meter is indicated for about 30 seconds after ignition switch has been turned OFF.
- Odo/trip meter segment can be checked in diagnosis mode.
- Meter/gauge can be checked in diagnosis mode.

HOW TO CHANGE THE DISPLAY FOR ODO/TRIP METER

NBEL0042S07

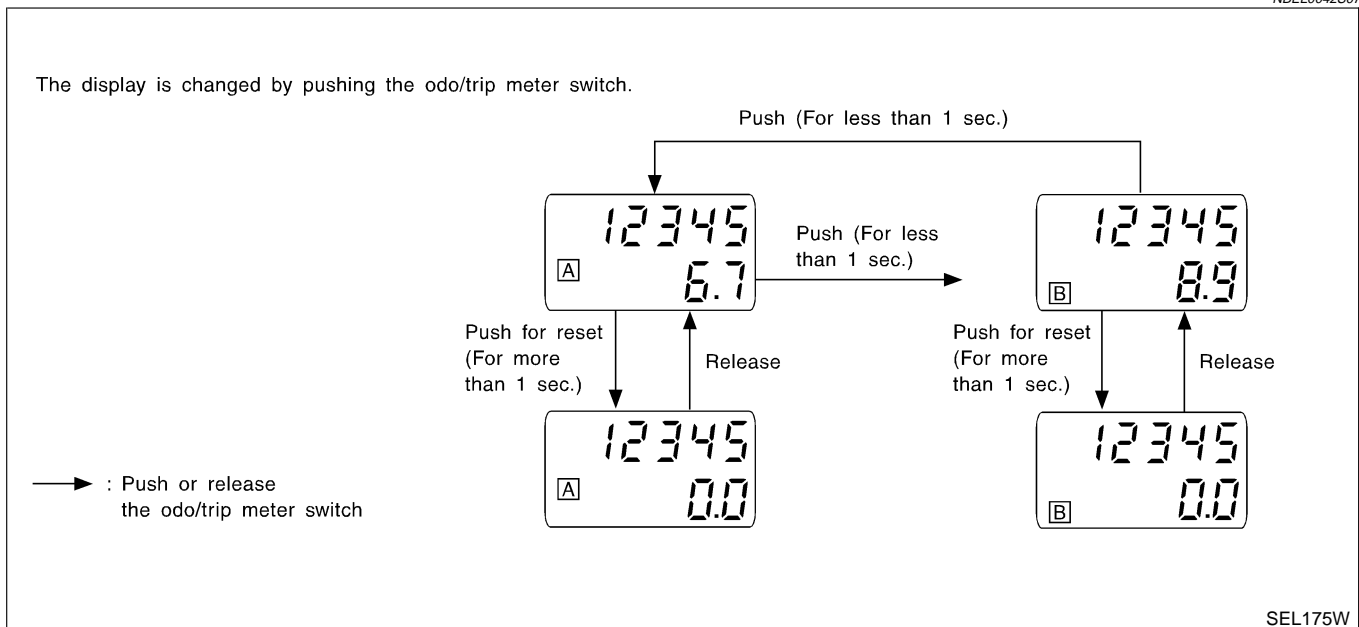

SEL175W

NOTE:

Turn ignition switch to the "ON" position to operate odo/trip meter.

POWER SUPPLY AND GROUND CIRCUIT

NBEL0042S08

Power is supplied at all times

- through 7.5A fuse [No. 24, located in the fuse block (J/B)]
- to combination meter terminal 62.

GI

With the ignition switch in the ON or START position, power is supplied

- through 10A fuse [No. 8, located in the fuse block (J/B)]
- to combination meter terminal 66.

MA

Ground is supplied

- to combination meter terminal 59
- through body grounds M4, M66 and M147.

EM

LC

WATER TEMPERATURE GAUGE

NBEL0042S01

The water temperature gauge indicates the engine coolant temperature. The reading on the gauge is based on the resistance of the thermal transmitter.

As the temperature of the coolant increases, the resistance of the thermal transmitter decreases. A variable ground is supplied to terminal 18 of the combination meter for the water temperature gauge. The needle on the gauge moves from "C" to "H".

EC

FE

TACHOMETER

NBEL0042S02

The tachometer indicates engine speed in revolutions per minute (rpm).

The tachometer is regulated by a signal

- from terminal 25 of the ECM
- to combination meter terminal 16 for the tachometer.

AT

TF

FUEL GAUGE

NBEL0042S03

The fuel gauge indicates the approximate fuel level in the fuel tank.

The fuel gauge is regulated by a variable ground signal supplied

- to combination meter terminal 17 for the fuel gauge
- from terminal 3 of the fuel level sensor unit
- through terminal 2 of the fuel level sensor unit and
- through body grounds B11, B22 and D210.

PD

AX

SU

SPEEDOMETER

NBEL0042S04

The vehicle speed sensor provides a voltage signal to the combination meter for the speedometer.

The voltage is supplied

- from combination meter terminal 15 for the speedometer
- to terminal 2 of the vehicle speed sensor.

BR

ST

The speedometer converts the voltage into the vehicle speed displayed.

RS

BT

HA

SC

EL

IDX

METERS AND GAUGES

Combination Meter (Cont'd)

CONSTRUCTION

NBEL0043S02

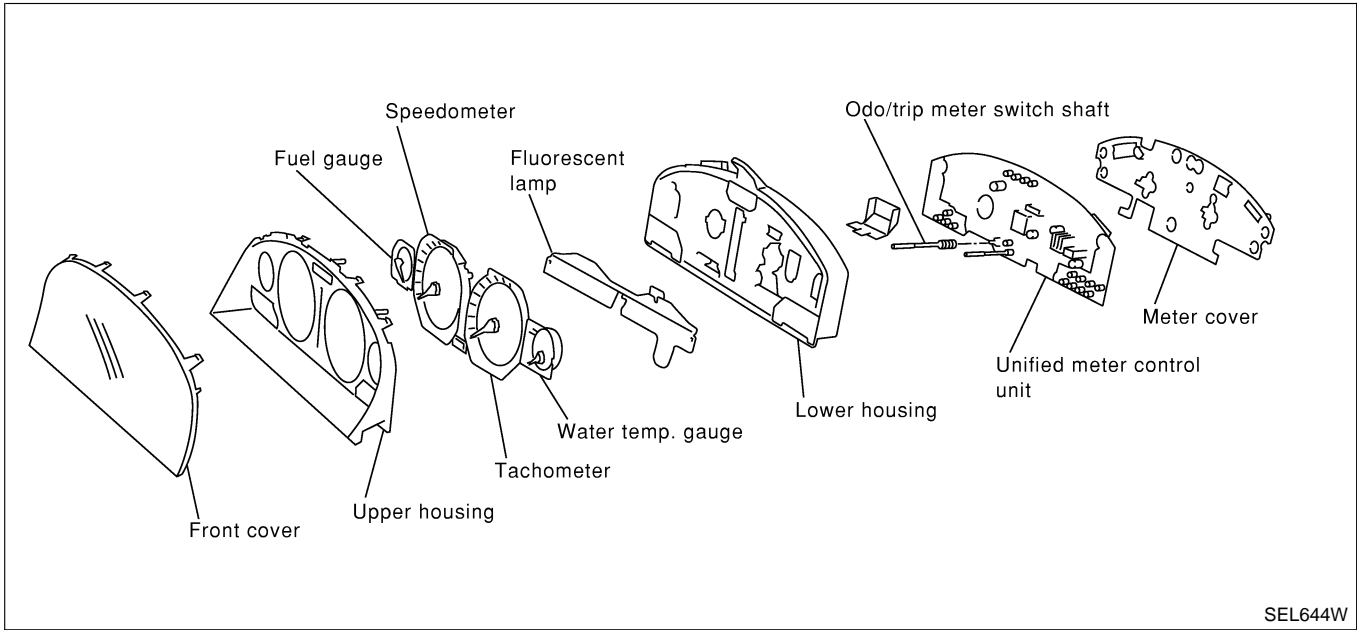

GI

MA

EM

LC

EC

FE

AT

TF

PD

AX

SU

BR

ST

RS

BT

HA

SC

EL

IDX

METERS AND GAUGES

Schematic

Schematic

NBEL0199

4W : With 4-wheel drive

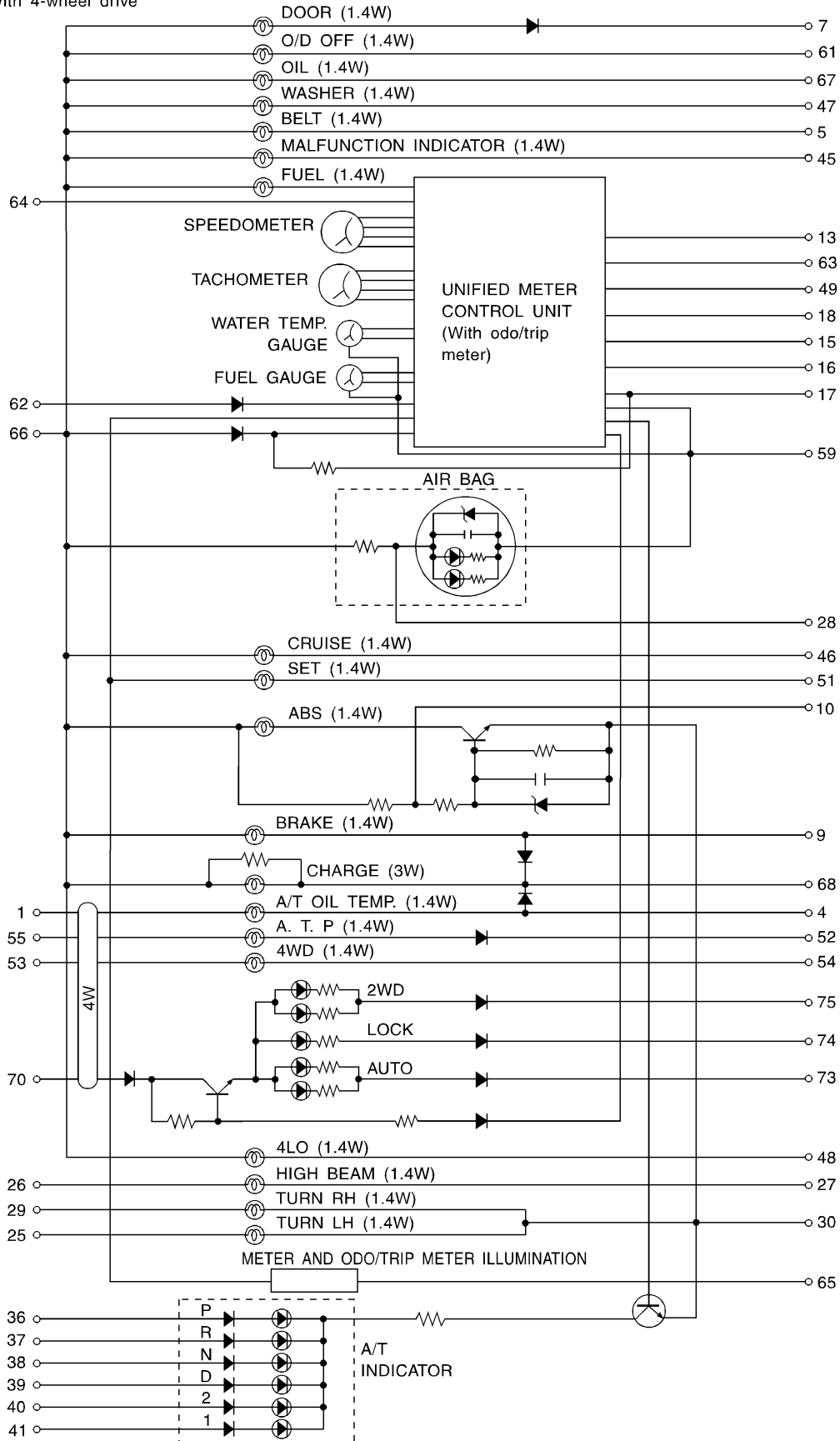

MEL131M

METERS AND GAUGES

Wiring Diagram — METER —

Wiring Diagram — METER —

NBEL0045

EL-METER-01

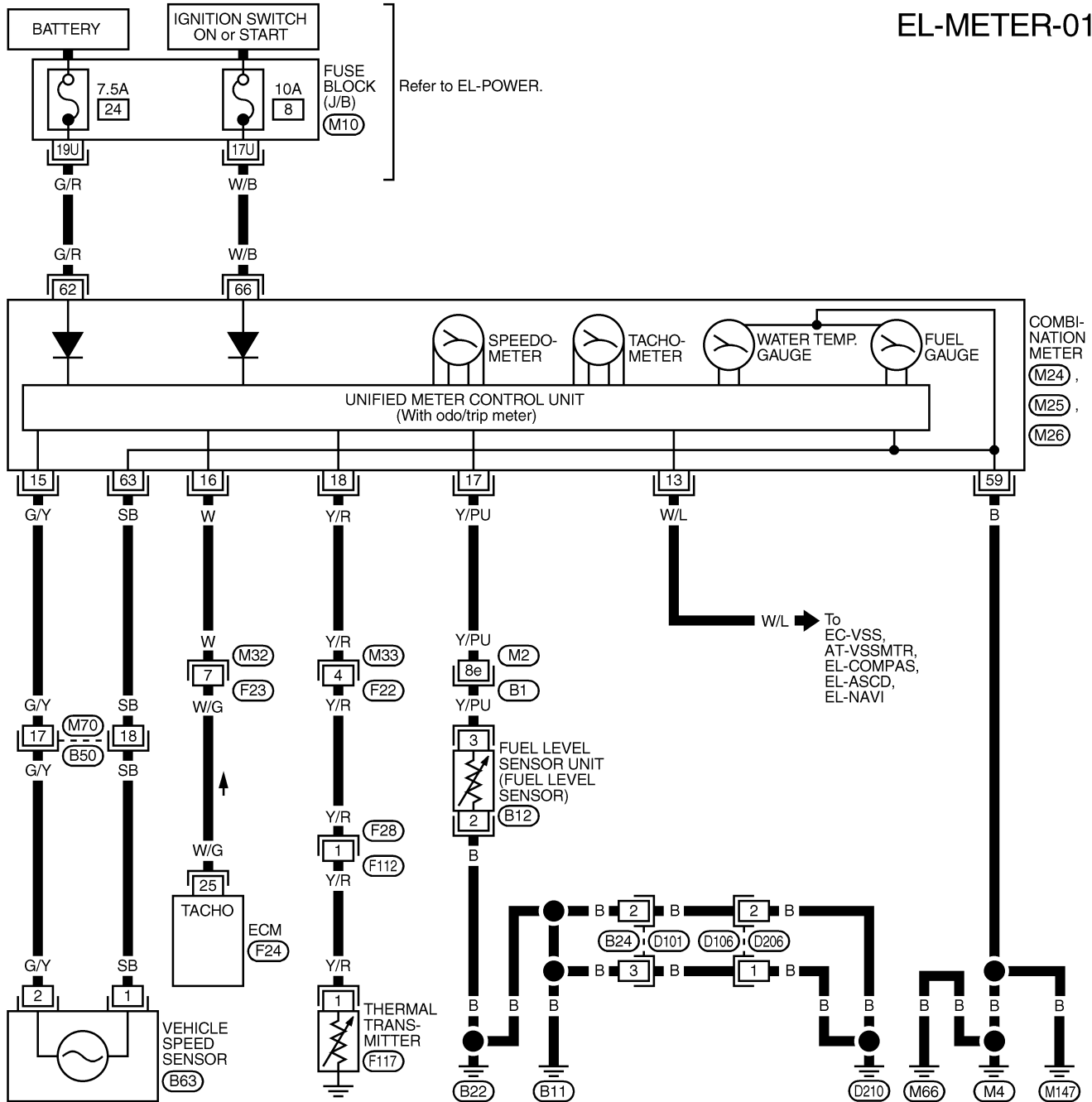

GI
MA
EM
LC
EC
FE
AT
TF
PD
AX
SU
BR
ST
RS
BT

HA
SC
EL
IDX

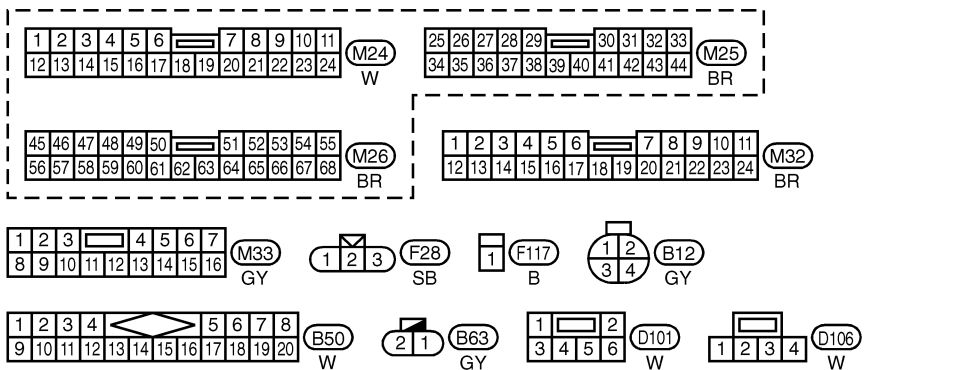

REFER TO THE FOLLOWING.
 (B1) -SUPER
 MULTIPLE JUNCTION (SMJ)
 (M10) -FUSE BLOCK-
 JUNCTION BOX (J/B)
 (F24) -ELECTRICAL UNITS

MEL793L

METERS AND GAUGES

Meter/Gauge Operation and Odo/Trip Meter Segment Check in Diagnosis Mode

Meter/Gauge Operation and Odo/Trip Meter Segment Check in Diagnosis Mode

NBEL0200

DIAGNOSIS FUNCTION

NBEL0200S01

- Odo/trip meter segment can be checked in diagnosis mode.
- Meters/gauges can be checked in diagnosis mode.

HOW TO ALTERNATE DIAGNOSIS MODE

NBEL0200S02

1. Turn ignition switch to ON and change odo/trip meter to "TRIP A" or "TRIP B".
2. Turn ignition switch to OFF.
3. Turn ignition switch to ON when pushing odo/trip meter switch.
4. Push odo/trip meter switch 1 second.
5. Release odo/trip meter switch.
6. Push odo/trip meter switch more than three times within 7 seconds.

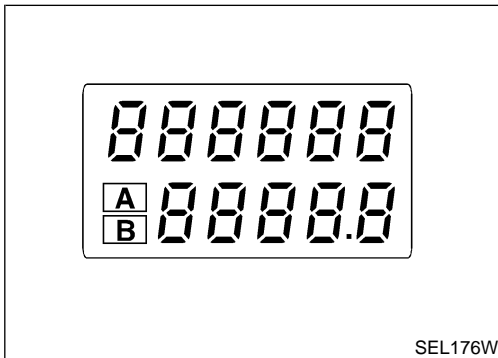

SEL176W

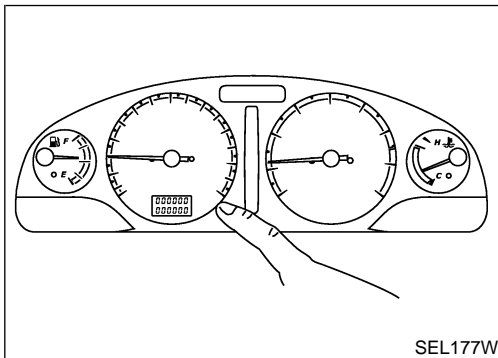

SEL177W

7. All odo/trip meter segments should be turned on.

NOTE:

If some segments are not turned on, unified meter control unit with odo/trip meter should be replaced.

At this point, the unified control meter is turned to diagnosis mode.

8. Push odo/trip meter switch. Indication of each meter/gauge should be as shown left during pushing odo/trip meter switch if it is no malfunctioning.

NOTE:

It takes about a few seconds for indication of fuel gauge and water temperature gauge to become stable.

Trouble Diagnoses PRELIMINARY CHECK

NBEL0201

NBEL0201S01

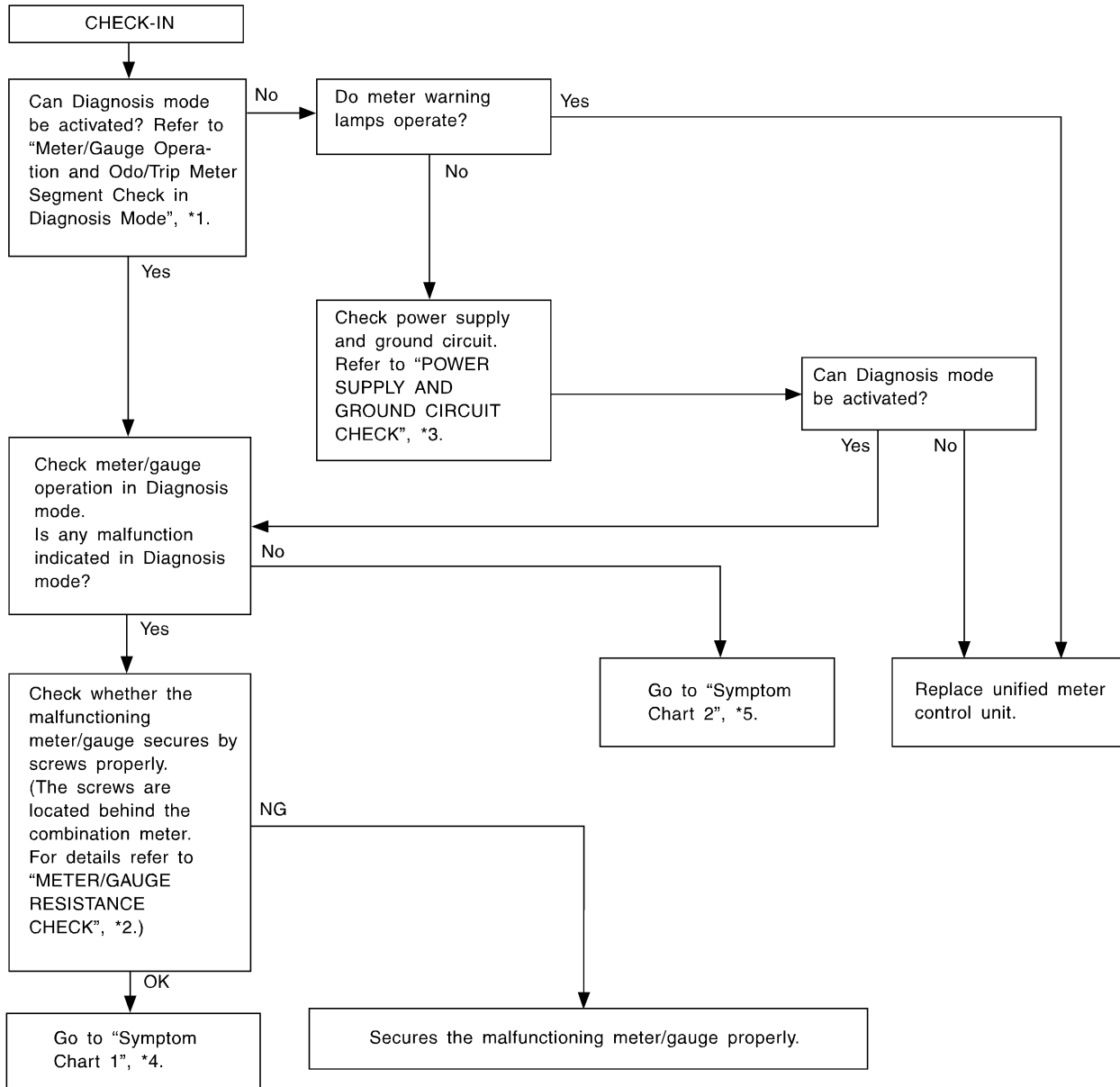

*1: Meter/Gauge Operation and Odo/Trip Meter Segment Check in Diagnosis Mode (EL-100)
 *2: METER/GAUGE RESISTANCE CHECK (EL-108)

*3: POWER SUPPLY AND GROUND CIRCUIT CHECK (EL-103)
 *4: Symptom Chart 1 (EL-102)

*5: Symptom Chart 2 (EL-102)

SEL361W

GI
MA
EM
LC
EC
FE
AT
TF
PD
AX
SU
BR
ST
RS
BT
HA
SC
EL
IDX

METERS AND GAUGES

Trouble Diagnoses (Cont'd)

SYMPTOM CHART

Symptom Chart 1 (Malfunction is Indicated in Diagnosis Mode)

NBEL0201S02

NBEL0201S0201

Symptom	Possible causes	Repair order
Odo/trip meter indicate(s) malfunction in Diagnosis mode.	Unified meter control unit	Replace unified meter control unit.
Multiple meter/gauge indicate malfunction in Diagnosis mode.		
One of speedometer/tachometer/fuel gauge/water temp. gauge indicates malfunction in Diagnosis mode.	<ol style="list-style-type: none"> Meter/Gauge Unified meter control unit 	<ol style="list-style-type: none"> Check resistance of meter/gauge indicating malfunction. If the resistance is NG, replace the meter/gauge. Refer to "METER/GAUGE RESISTANCE CHECK", EL-108. If the resistance of meter/gauge is OK, replace unified meter control unit.

Symptom Chart 2 (No Malfunction is Indicated in Diagnosis Mode)

NBEL0201S0202

Symptom	Possible causes	Repair order
One of speedometer/tachometer/fuel gauge/water temp. gauge is malfunctioning.	<ol style="list-style-type: none"> Sensor signal <ul style="list-style-type: none"> Vehicle speed signal Engine revolution signal Fuel gauge Water temp. gauge Unified meter control unit 	<ol style="list-style-type: none"> Check the sensor for malfunctioning meter/gauge. INSPECTION/VEHICLE SPEED SENSOR (Refer to EL-104.) INSPECTION/ENGINE REVOLUTION SIGNAL (Refer to EL-105.) INSPECTION/FUEL LEVEL SENSOR UNIT (Refer to EL-106.) INSPECTION/THERMAL TRANSMITTER (Refer to EL-107.) Replace unified meter control unit.
Multiple meter/gauge are malfunctioning. (except odo/trip meter)		

Before starting trouble diagnoses below, perform PRELIMINARY CHECK, EL-101.

METERS AND GAUGES

Trouble Diagnoses (Cont'd)

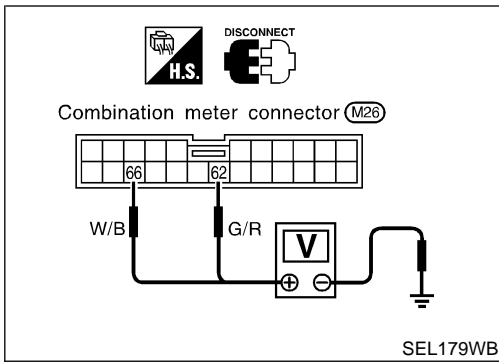

POWER SUPPLY AND GROUND CIRCUIT CHECK

=NBEL0201S03

Power Supply Circuit Check

NBEL0201S0301

Terminals		Ignition switch position		
(+)	(-)	OFF	ACC	ON
62	Ground	Battery voltage	Battery voltage	Battery voltage
66	Ground	0V	0V	Battery voltage

If NG, check the following.

- 10A fuse [No. 12, located in fuse block (J/B)]
- 10A fuse [No. 30, located in fuse block (J/B)]
- Harness for open or short between fuse and combination meter

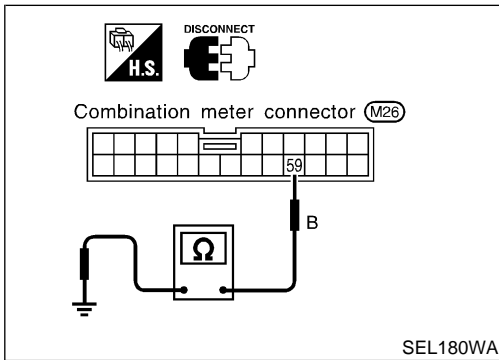

Ground Circuit Check

NBEL0201S0302

Terminals	Continuity
59 - Ground	Yes

GI
MA
EM
LC
EC
FE
AT
TF
PD
AX
SU
BR
ST
RS
BT
HA
SC
EL
IDX

METERS AND GAUGES

Trouble Diagnoses (Cont'd)

INSPECTION/VEHICLE SPEED SENSOR

=NBEL0201S04

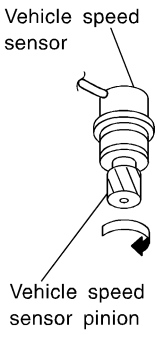
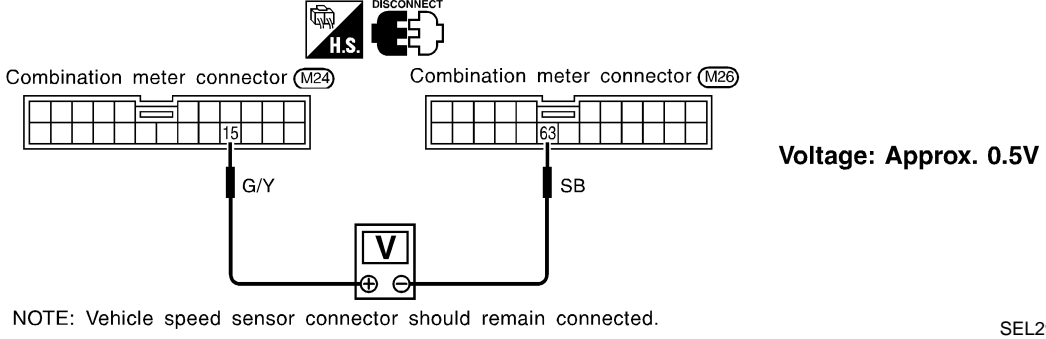
1	CHECK VEHICLE SPEED SENSOR OUTPUT		
<p>1. Remove vehicle speed sensor from transmission. 2. Check voltage between combination meter terminals 15 and 63 while quickly turning speed sensor pinion.</p>			
 <p>Vehicle speed sensor</p> <p>Vehicle speed sensor pinion</p>		 <p>Combination meter connector (M24)</p> <p>Combination meter connector (M26)</p> <p>15</p> <p>63</p> <p>G/Y</p> <p>SB</p> <p>V</p> <p>NOTE: Vehicle speed sensor connector should remain connected.</p> <p>Voltage: Approx. 0.5V</p>	
OK or NG			
OK	▶	Vehicle speed sensor is OK.	
NG	▶	GO TO 2.	

SEL297X

2	CHECK VEHICLE SPEED SENSOR		
Check resistance between vehicle speed sensor terminals 1 and 2.			
 <p>Vehicle speed sensor connector (B63)</p> <p>1</p> <p>2</p> <p>Ω</p> <p>Resistance: Approx. 250Ω</p>			
OK or NG			
OK	▶	Check harness or connector between speedometer and vehicle speed sensor.	
NG	▶	Replace vehicle speed sensor.	

SEL298X

INSPECTION/ENGINE REVOLUTION SIGNAL

NBEL0201S05

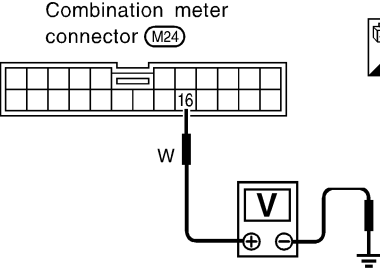
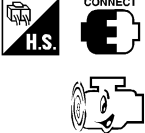
1	CHECK ECM OUTPUT	<p>1. Start engine. 2. Check voltage between combination meter terminals 16 and ground at idle and 2,000 rpm.</p> <div style="display: flex; justify-content: space-around; align-items: center;"> <div style="text-align: center;"> <p>Combination meter connector (M24)</p>  </div> <div style="text-align: center;">  </div> <div style="text-align: center;"> <p>Higher rpm = Higher voltage Lower rpm = Lower voltage Voltage should change with rpm.</p> </div> </div> <p style="text-align: right;">SEL364WB</p>	
OK or NG			
OK	▶	Engine revolution signal is OK.	
NG	▶	Harness for open or short between ECM and combination meter	

GI

MA

EM

LC

EC

FE

AT

TF

PD

AX

SU

BR

ST

RS

BT

HA

SC

EL

IDX

METERS AND GAUGES



Trouble Diagnoses (Cont'd)

INSPECTION/FUEL LEVEL SENSOR UNIT

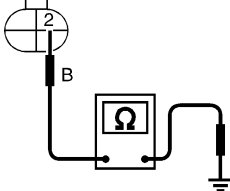
=NBEL0201S06

1	CHECK GROUND CIRCUIT FOR FUEL LEVEL SENSOR UNIT	
<p>Check harness continuity between fuel level sensor unit terminal 2 and ground.</p> <div style="display: flex; justify-content: space-around; align-items: center;"> <div style="text-align: center;">  <p>Fuel level sensor unit connector (B12)</p> </div> <div style="text-align: center;"> <p>Continuity should exist.</p> </div> </div> <div style="text-align: center; margin-top: 20px;">  </div> <p style="text-align: right;">SEL299X</p>		
OK or NG		
OK	▶	GO TO 2.
NG	▶	Repair harness or connector.

2	CHECK FUEL LEVEL SENSOR UNIT	
<p>Refer to "FUEL LEVEL SENSOR UNIT CHECK" (EL-108).</p> <p style="text-align: center;">OK or NG</p>		
OK	▶	GO TO 3.
NG	▶	Replace fuel level sensor unit.

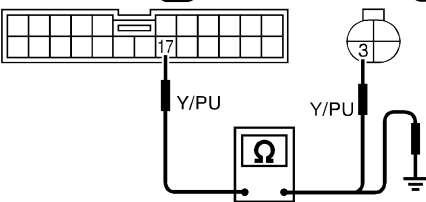
3	CHECK HARNESS FOR OPEN OR SHORT	
<ol style="list-style-type: none"> 1. Disconnect combination meter connector and fuel level sensor unit connector. 2. Check continuity between combination meter terminal 17 and fuel level sensor unit terminal 3. 3. Check continuity between combination meter terminal 17 and ground. 		
<div style="display: flex; justify-content: space-around; align-items: center;"> <div style="text-align: center;">  <p>Combination meter connector (M24)</p> </div> <div style="text-align: center;">  <p>Fuel level sensor unit connector (B12)</p> </div> <div style="text-align: center;"> <p>Continuity:</p> <p>Combination meter terminal 17 and fuel level sensor unit terminal 3</p> <p>Yes</p> <p>Combination meter terminal 17 and ground</p> <p>No</p> </div> </div> <div style="text-align: center; margin-top: 20px;">  </div> <p style="text-align: right;">SEL300X</p>		
OK or NG		
OK	▶	Fuel level sensor unit is OK.
NG	▶	Repair harness or connector.

METERS AND GAUGES

Trouble Diagnoses (Cont'd)

INSPECTION/THERMAL TRANSMITTER

=NBEL0201S07

1	CHECK THERMAL TRANSMITTER	
Refer to "THERMAL TRANSMITTER CHECK" (EL-108).		
OK or NG		
OK	▶	GO TO 2.
NG	▶	Replace.

GI
MA
EM

2	CHECK HARNESS FOR OPEN OR SHORT	
<ol style="list-style-type: none"> 1. Disconnect combination meter connector and thermal transmitter connector. 2. Check continuity between combination meter terminal 18 and thermal transmitter terminal 1. Continuity should exist. 3. Check continuity between combination meter terminal 18 and ground. Continuity should not exist. 		
SEL184WA		
OK or NG		
OK	▶	Thermal transmitter is OK.
NG	▶	Repair harness or connector.

LC
EC
FE
AT
TF
PD
AX
SU

BR
ST
RS
BT
HA
SC

EL

IDX

METERS AND GAUGES

Electrical Components Inspection

=NBEL0202

METER/GAUGE RESISTANCE CHECK

NBEL0202S01

Check resistance between installation screws of meter/gauge.

Screws		Resistance Ω
Tacho/Speedometer	Fuel/Temp. gauge	
A - C	A - C	Approx. 190 - Approx. 260
B - D	B - C	Approx. 230 - Approx. 310

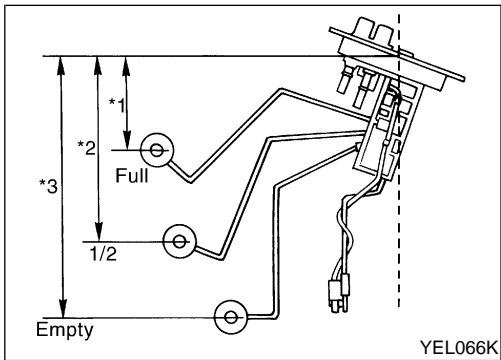
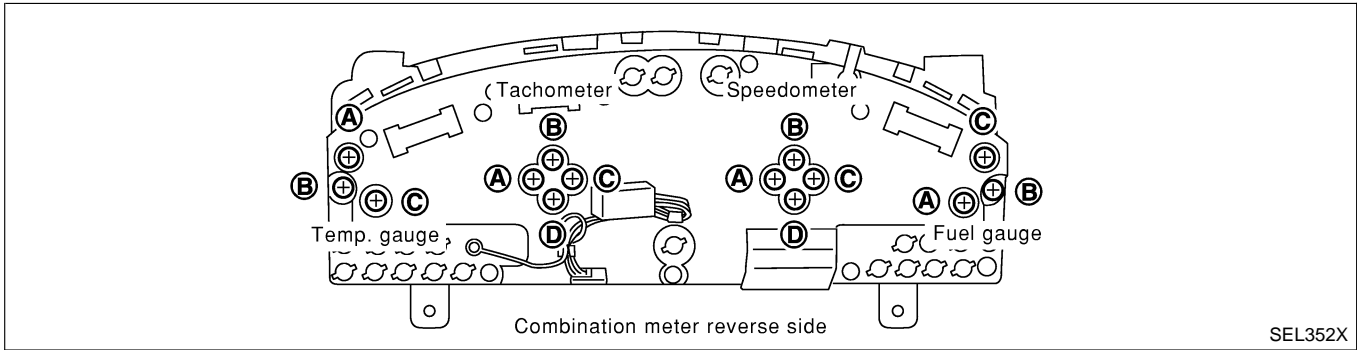

FUEL LEVEL SENSOR UNIT CHECK

NBEL0202S02

- For removal, refer to FE-4, "FUEL SYSTEM".

Check the resistance between terminals 3 and 2.

Ohmmeter		Float position		mm (in)	Resistance value Ω
(+)	(-)				
3	2	*1	Full	95 (3.74)	Approx. 4 - 6
		*2	1/2	184 (7.24)	31 - 34
		*3	Empty	265 (10.43)	80 - 83

*1 and *3: When float rod is in contact with stopper.

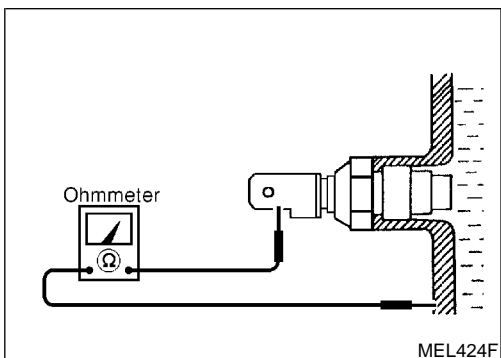

THERMAL TRANSMITTER CHECK

NBEL0202S03

Check the resistance between the terminals of thermal transmitter and body ground.

Water temperature	Resistance
60°C (140°F)	Approx. 170 - 210Ω
100°C (212°F)	Approx. 47 - 53Ω

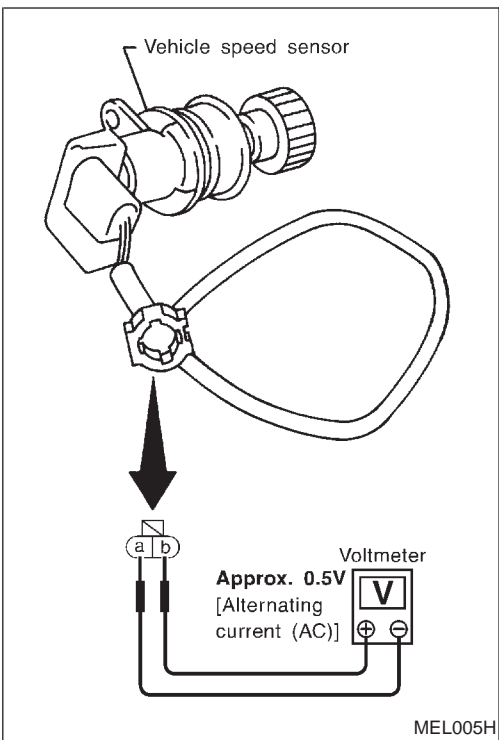

VEHICLE SPEED SENSOR SIGNAL CHECK

NBEL0202S04

1. Remove vehicle speed sensor from transmission.
2. Turn vehicle speed sensor pinion quickly and measure voltage across a and b.

GI

MA

EM

LC

EC

FE

AT

TF

PD

AX

SU

BR

ST

RS

BT

HA

SC

EL

IDX

COMPASS AND THERMOMETER

System Description

System Description

NBEL0153

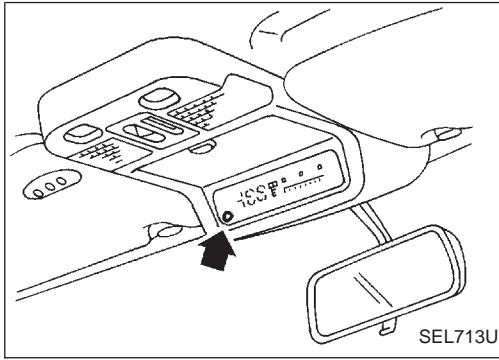

This unit displays following items:

- Earth magnetism and heading direction of vehicle.
- Outside air temperature.
- Caution for frozen road surfaces.

OUTSIDE TEMPERATURE DISPLAY

Push the switch when the ignition key is in the “ACC” or “ON” position. The outside temperature will be displayed in “°F”. NBEL0153S01

- Selecting the indication range
Push the switch to change from “°F” to “°C”.
- When the outside temperature drops below freezing point, ICE is displayed on the unit.
- When the outside temperature is between 55°C (130°F) and 70°C (158°F), the display shows 55°C (130°F).
- When the outside temperature is lower than -30°C (-20°F) or higher than 70°C (158°F), the display shows only “---” though it is operating. This is not a problem.
- The indicated temperature on the thermometer is not readily affected by engine heat. It changes only when one of the following conditions is present.
 - a) The temperature detected by the ambient air temperature sensor is lower than the indicated temperature on the thermometer.
 - b) The difference in temperature detected during a period of 40 seconds is less than 1°C (1.8°F) when vehicle speed has been greater than 24 km/h (15 MPH) for more than 100 seconds.
(This is to prevent the indicated temperature from being affected by engine heat or cooling fan operation during low-speed driving.)
 - c) The ignition key has been turned to the “OFF” position for more than 4 hours. (The engine is cold.)

DIRECTION DISPLAY

Push the switch when the ignition key is in the “ACC” or “ON” position. The direction will be displayed. NBEL0153S02

COMPASS AND THERMOMETER

Wiring Diagram — COMPAS —

Wiring Diagram — COMPAS —

NBEL0154

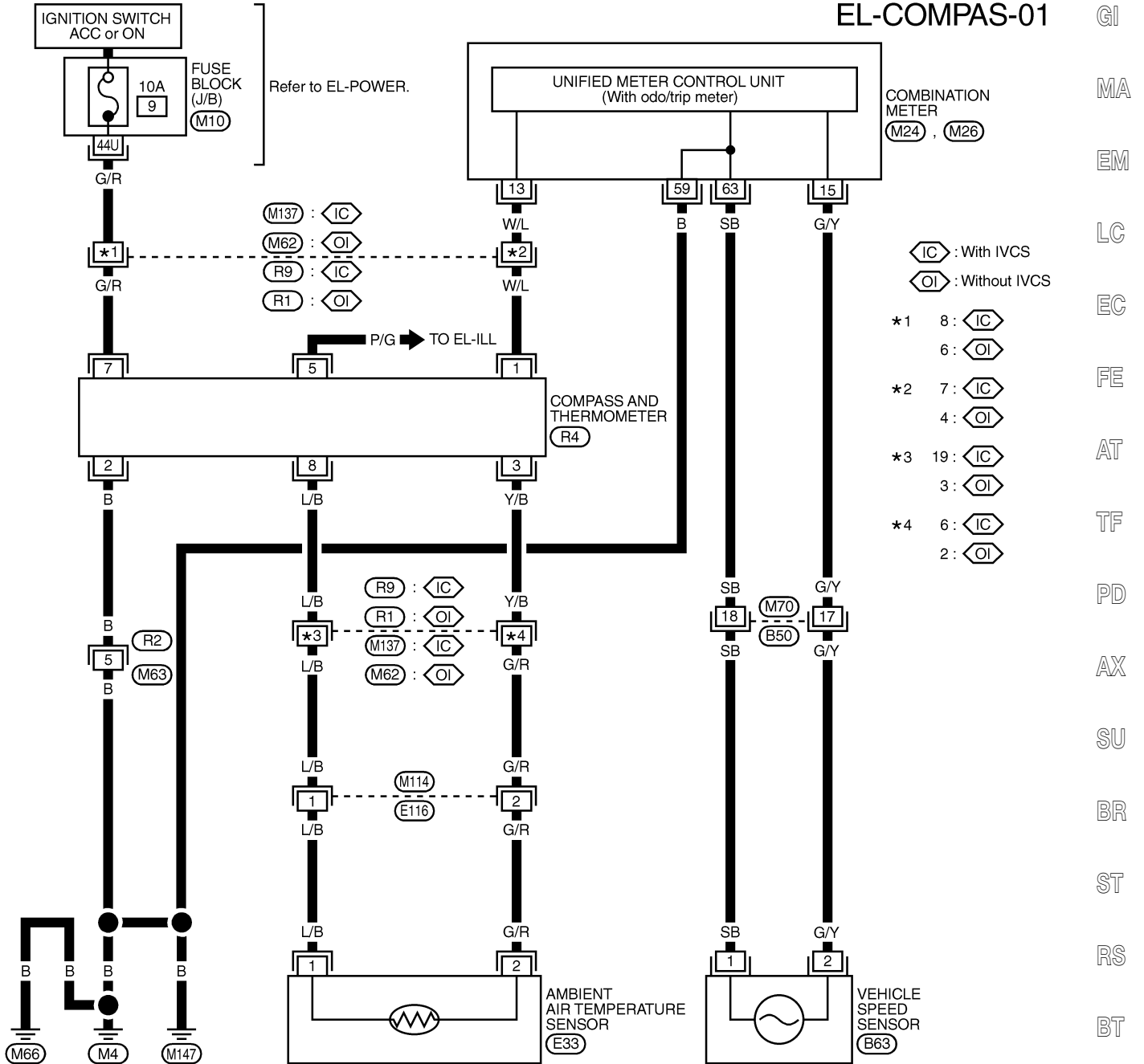

GI
MA
EM
LC
EC
FE
AT
TF
PD
AX
SU
BR
ST
RS
BT
HA
SC
EL
IDX

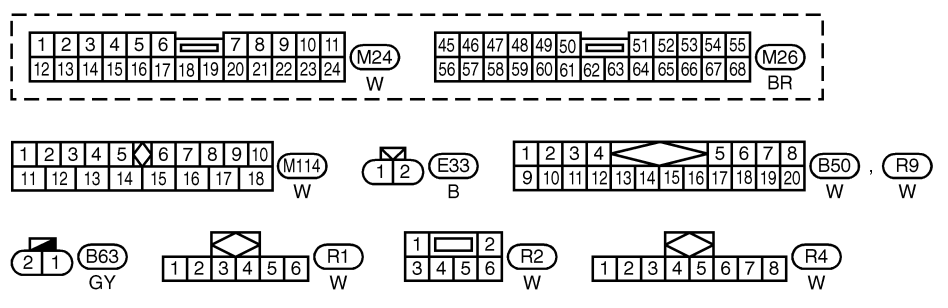

MEL803L

COMPASS AND THERMOMETER

Trouble Diagnoses

Trouble Diagnoses

NBEL0048

PRELIMINARY CHECK FOR THERMOMETER

NBEL0048S02

1	COOL DOWN CHECK	
1. Turn the ignition key switch to the "ACC" position. 2. Cool down the ambient air temperature sensor with water or ice, so that the indicated temperature falls.		
Does the indicated temperature fall?		
Yes	▶	GO TO 2.
No	▶	The system is malfunctioning. Check the system following "INSPECTION/COMPASS AND THERMOMETER".

2	WARM UP CHECK	
1. Leave the vehicle for 10 minutes, so that the indicated temperature rises. 2. With the ignition key in the "ACC" position, disconnect and reconnect the ambient air temperature sensor connector.		
Does the indicated temperature rise?		
Yes	▶	The system is OK.
No	▶	The system is malfunctioning. Check the system following "INSPECTION/COMPASS AND THERMOMETER".

NOTE:

- When the outside temperature is between 55°C (130°F) and 70°C (158°F), the display shows 55°C (130°F). When the outside temperature is lower than -30°C (-20°F) or higher than 70°C (158°F), the display shows only "---".
- The indicated temperature on the thermometer is not readily affected by engine heat. It changes only when one of the following conditions is present.
 - a) The temperature detected by the ambient air temperature sensor is lower than the indicated temperature on the thermometer.
 - b) The difference in temperature detected during a period of 40 seconds is less than 1°C (1.8°F) when vehicle speed has been greater than 24 km/h (15 MPH) for more than 100 seconds.
(This is to prevent the indicated temperature from being affected by engine heat or cooling fan operation during low-speed driving.)
 - c) The ignition key has been turned to the "OFF" position for more than 4 hours. (The engine is cold.)

INSPECTION/COMPASS AND THERMOMETER

NBEL0048S01

Symptom	Possible causes	Repair order
No display at all	1. 10A fuse 2. Ground circuit 3. Compass and thermometer	1. Check 10A fuse [No. 9, located in fuse block (J/B)]. Turn the ignition switch ON and verify that battery positive voltage is at terminal 7 of compass and thermometer. 2. Check ground circuit for compass and thermometer. 3. Replace compass and thermometer.
Forward direction indication slips off the mark or incorrect.	1. In manual correction mode (Bar and display vanish.) 2. Zone variation change is not done.	1. Drive the vehicle and turn at an angle of 90°. 2. Perform the zone variation change.
Compass reading remains unchanged.	1. Vehicle speed sensor is not entered. 2. Compass and thermometer	1. Check harness for open or short between combination meter terminal 13 and compass and thermometer terminal 1. 2. Replace compass and thermometer.
Displays wrong temperature when ambient temperature is between -30°C (-20°F) and 55°C (130°F). (See NOTE above.)	1. Check operation 2. Ambient air temperature sensor circuit 3. Vehicle speed sensor is not entered. 4. Ambient air temperature sensor 5. Compass and thermometer	1. Perform preliminary check shown above. 2. Check harness for open or short between ambient air temperature sensor and compass and thermometer. 3. Check harness for open or short between combination meter terminal 13 and compass and thermometer terminal 1. 4. Replace ambient air temperature sensor. 5. Replace compass and thermometer.

Calibration Procedure for Compass

NBEL0155

The difference between magnetic North and geographical North can sometimes be great enough to cause false compass readings. In order for the compass to operate accurately in a particular zone, it must be calibrated using the following procedure.

Zone Variation Chart

1. Determine your location on the zone map. Record your zone number.
2. Turn the ignition switch to ACC or ON position.
3. Push the "Mode" switch continuously for five seconds until the current zone entry number is displayed.
4. Press the "Mode" switch repeatedly until the desired zone number is displayed.

Once the desired zone number is displayed, stop pressing the "Mode" switch and the display will show compass direction after a few seconds.

SEL738UA

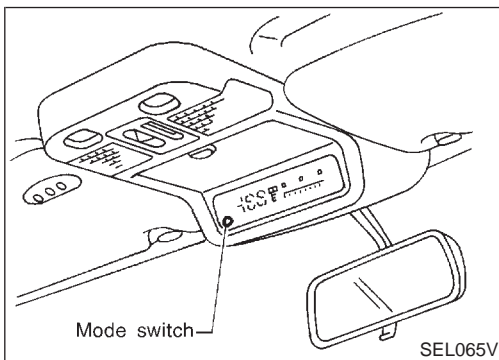

CORRECTION FUNCTIONS OF COMPASS

NBEL0155S01

The direction display is equipped with automatic correction function. If the direction is not shown correctly, carry out initial correction.

INITIAL CORRECTION PROCEDURE FOR COMPASS

NBEL0155S02

1. Pushing the "Mode" switch for about 10 seconds will enter the initial correction mode. The direction bar starts blinking.
2. Turn the vehicle slowly in an open, safe place. The initial correction is completed in one or two turns.

NOTE:

In places where the terrestrial magnetism is extremely disturbed, the initial correction may start automatically.

GI
MA
EM
LC
EC
FE
AT
TF
PD
AX
SU
BR
ST
RS
BT
HA
SC
EL
IDX

WARNING LAMPS

Schematic

NBEL0049

Schematic

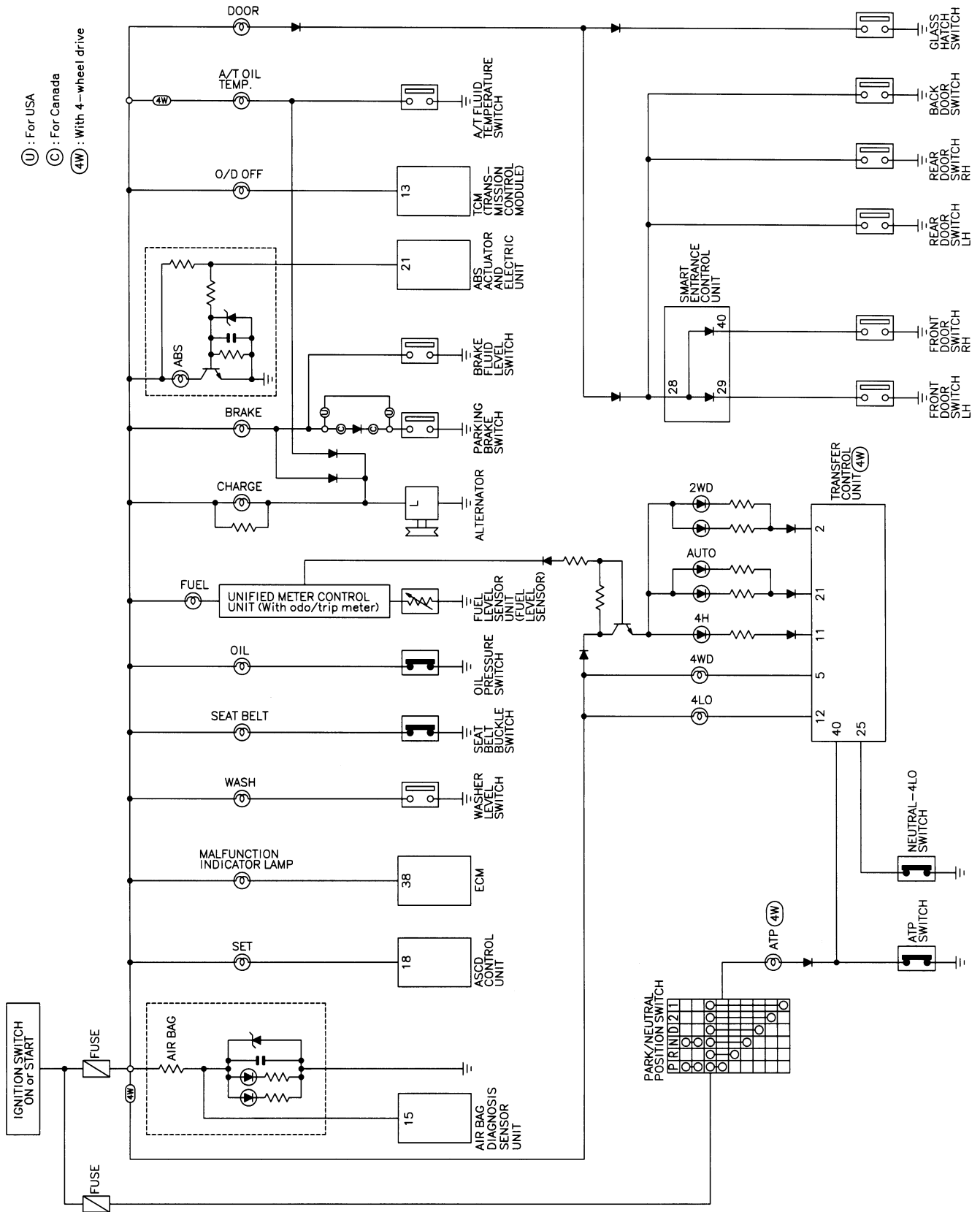

MEL794L

WARNING LAMPS

Wiring Diagram — WARN —

Wiring Diagram — WARN —

NBEL0050

EL-WARN-01

⬡4W : With 4-wheel drive

GI

MA

EM

LC

EC

FE

AT

TF

PD

AX

SU

BR

ST

RS

BT

HA

SC

EL

IDX

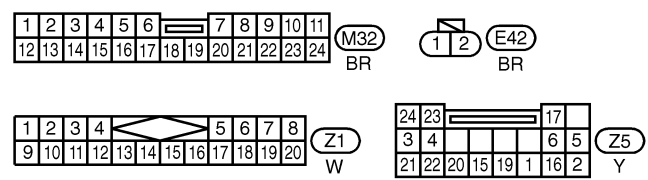
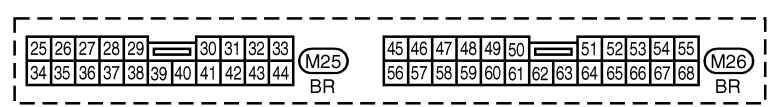
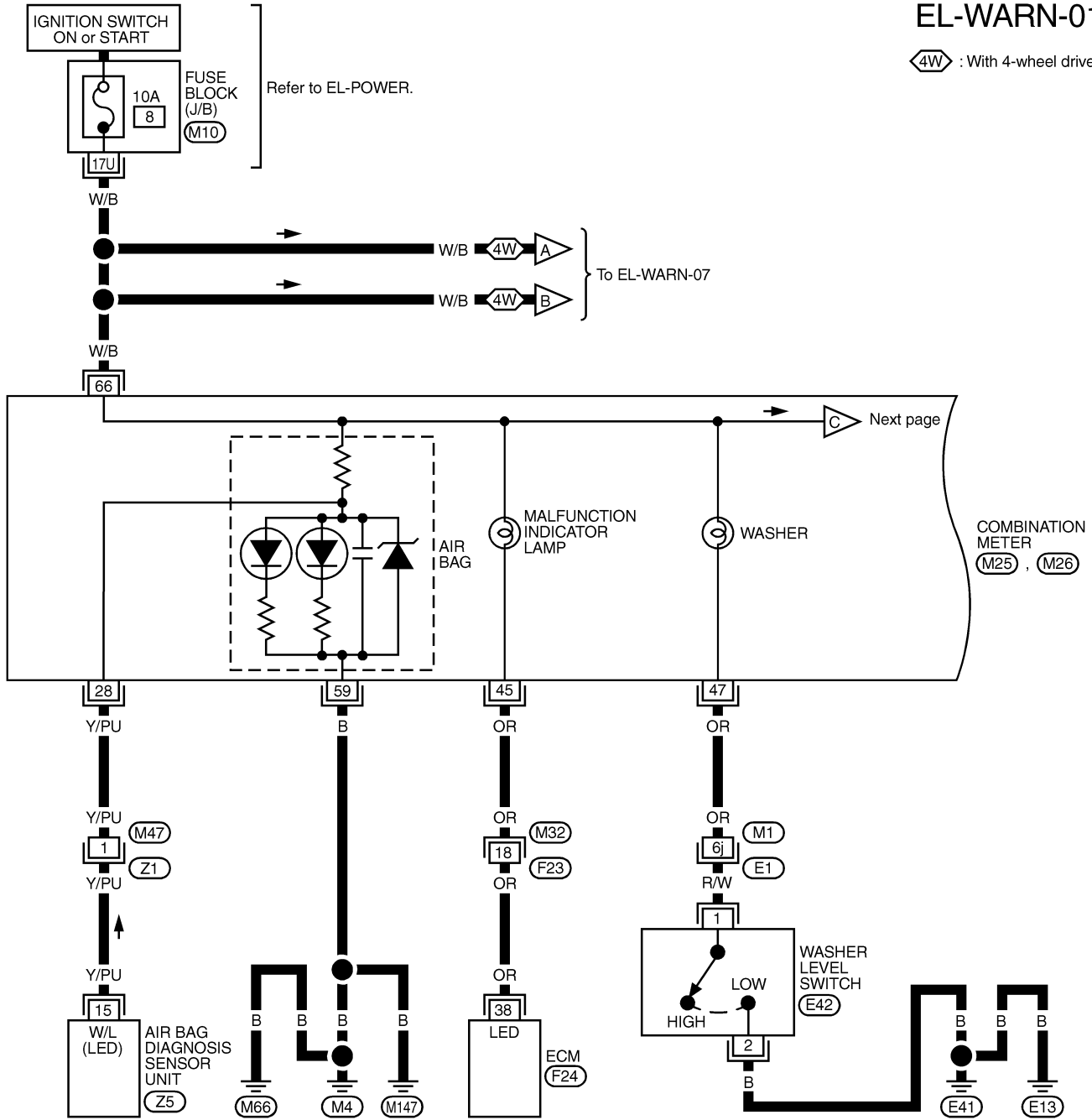

REFER TO THE FOLLOWING.
 (E1) -SUPER
 MULTIPLE JUNCTION (SMJ)
 (M10) - FUSE BLOCK-
 JUNCTION BOX (J/B)
 (F24) -ELECTRICAL UNITS

WARNING LAMPS

Wiring Diagram — WARN — (Cont'd)

EL-WARN-02

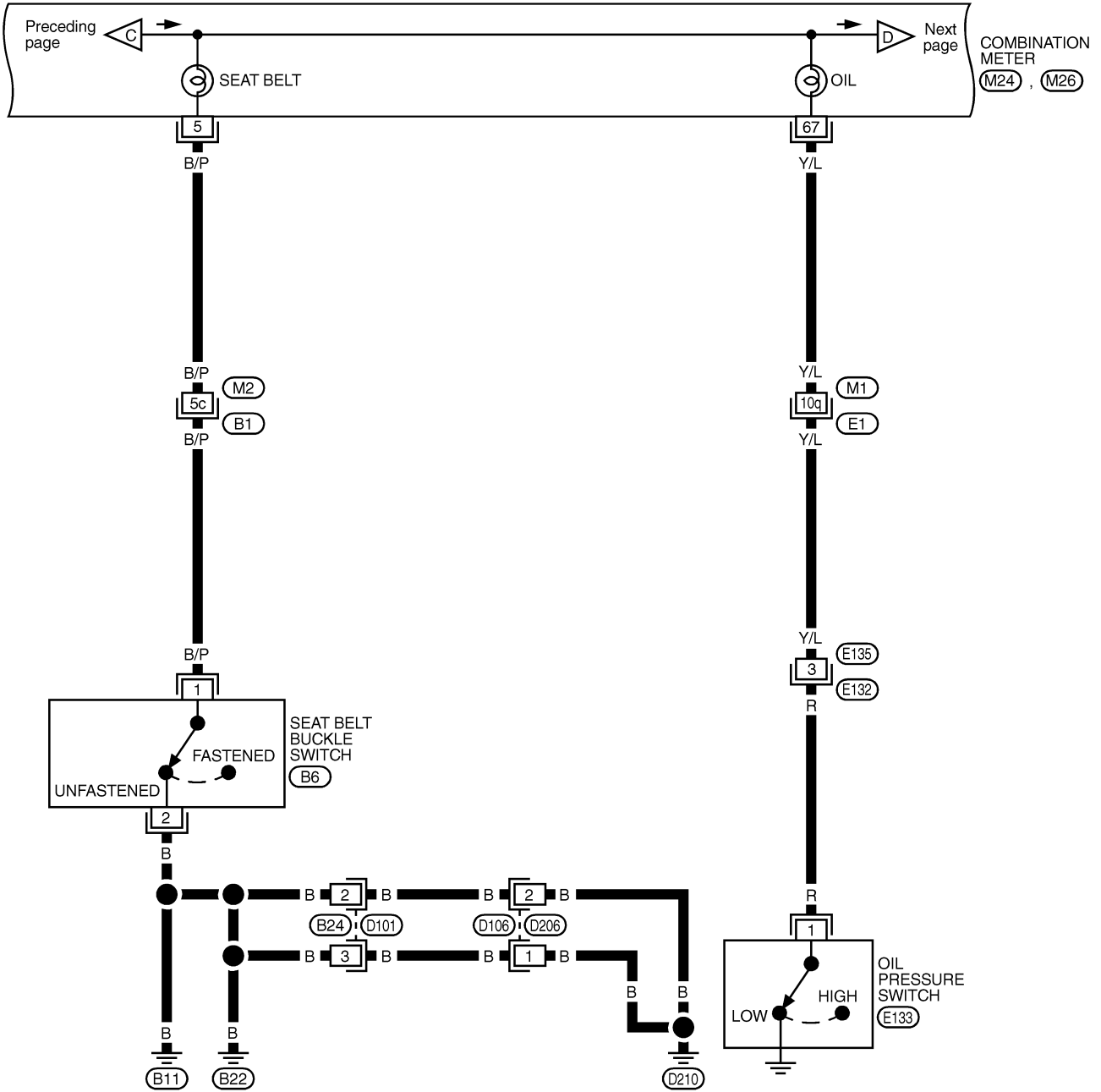

1	2	3	4	5	6	7	8	9	10	11	12	13	14	15	16	17	18	19	20	21	22	23	24	(M24) W	45	46	47	48	49	50	51	52	53	54	55	56	57	58	59	60	61	62	63	64	65	66	67	68	(M26) BR
---	---	---	---	---	---	---	---	---	----	----	----	----	----	----	----	----	----	----	----	----	----	----	----	------------	----	----	----	----	----	----	----	----	----	----	----	----	----	----	----	----	----	----	----	----	----	----	----	----	-------------

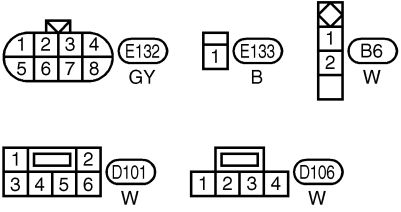

REFER TO THE FOLLOWING.
 (E1) , (B1) -SUPER
 MULTIPLE JUNCTION (SMJ)

MEL796L

WARNING LAMPS

Wiring Diagram — WARN — (Cont'd)

EL-WARN-03

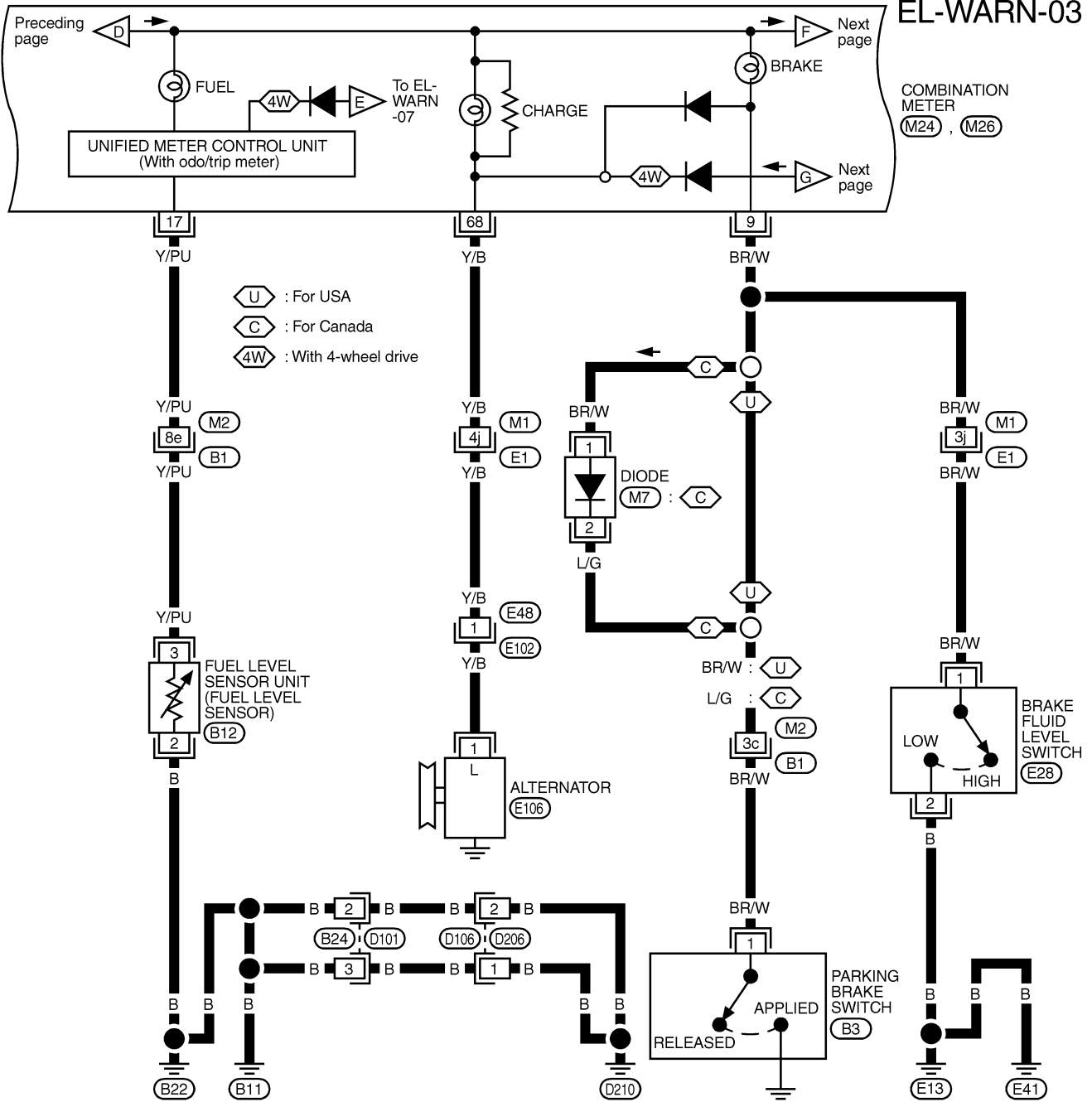

: For USA
 : For Canada
 : With 4-wheel drive

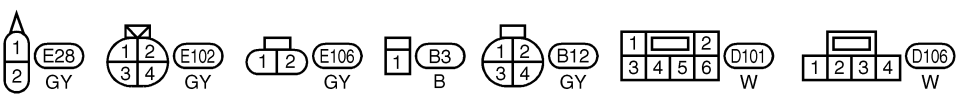
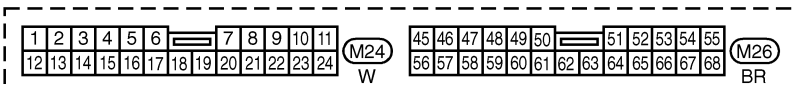
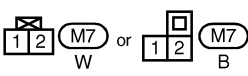

REFER TO THE FOLLOWING.
 (E1), (B1) - SUPER
 MULTIPLE JUNCTION (SMJ)

GI
MA
EM
LC
EC
FE
AT
TF
PD
AX
SU
BR
ST
RS
BT
HA
SC
EL
IDX

MEL0060

WARNING LAMPS

Wiring Diagram — WARN — (Cont'd)

EL-WARN-04

: With 4-wheel drive

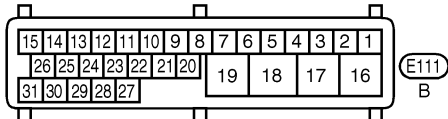
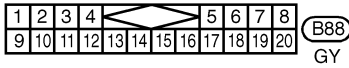
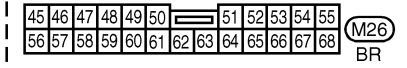
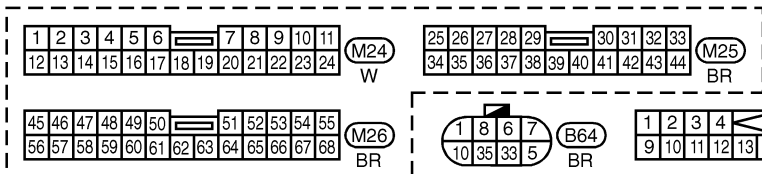
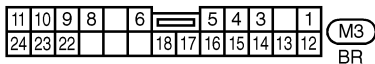
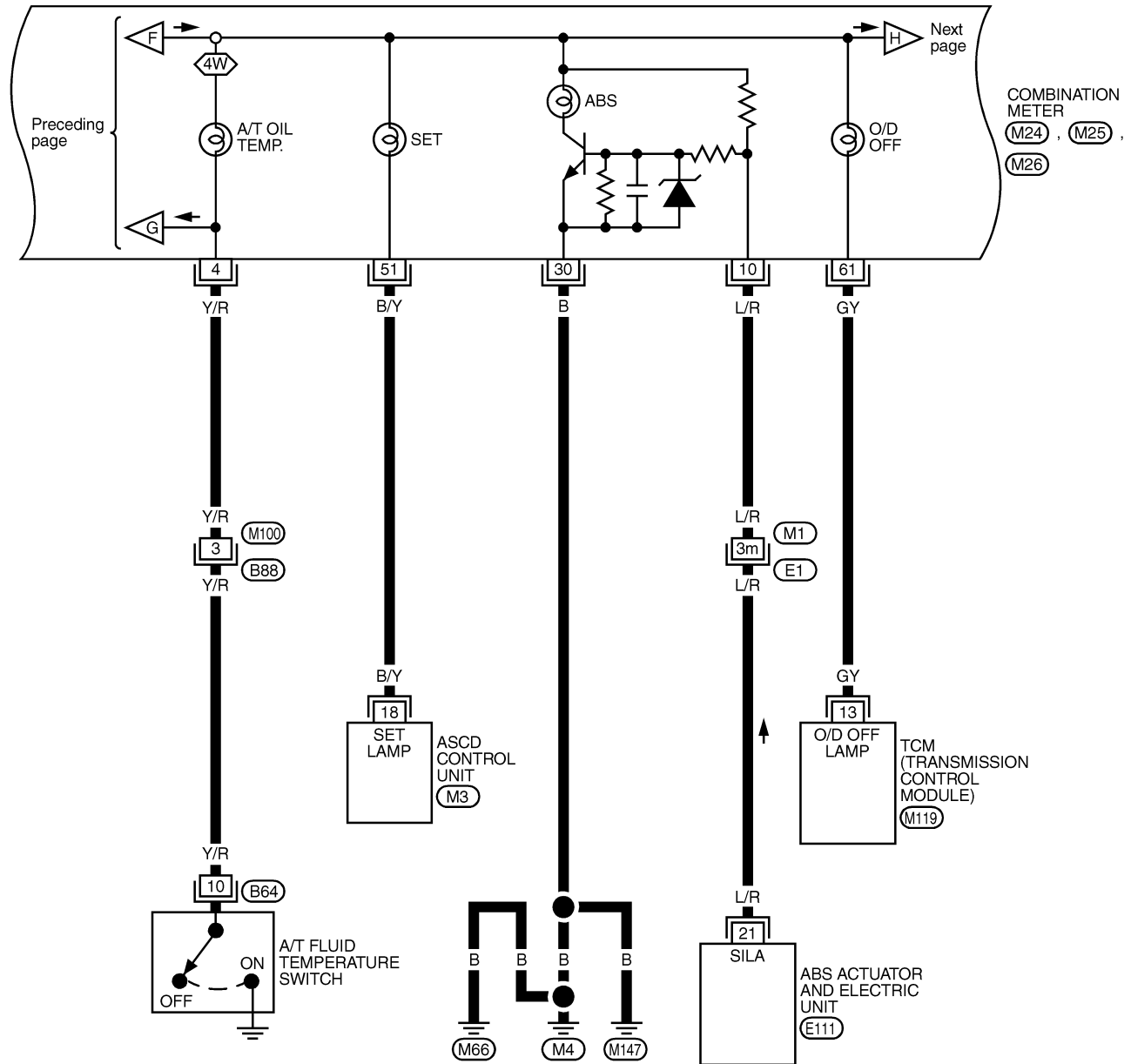

REFER TO THE FOLLOWING.
 -SUPER
 MULTIPLE JUNCTION (SMJ)
 -ELECTRICAL UNITS

MEL798L

WARNING LAMPS

Wiring Diagram — WARN — (Cont'd)

EL-WARN-05

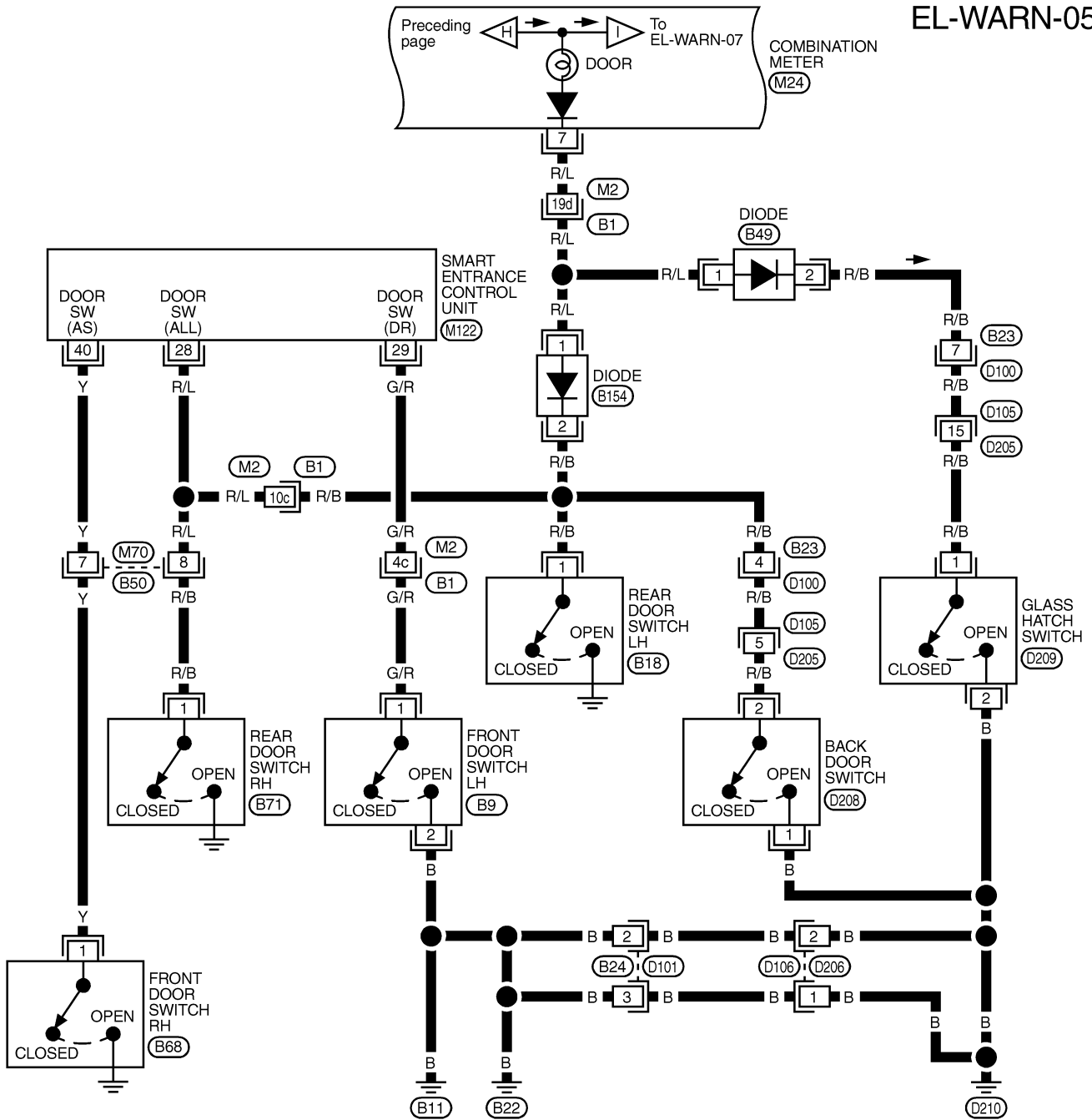

GI
MA
EM
LC
EC
FE
AT
TF
PD
AX
SU
BR
ST
RS
BT
HA
SC
EL
IDX

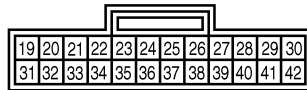
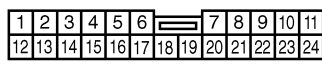

REFER TO THE FOLLOWING.
 (B1) - SUPER
 MULTIPLE JUNCTION (SMJ)

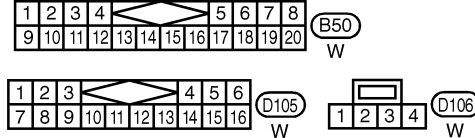
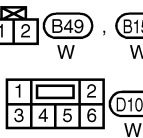
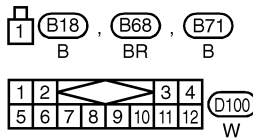

WARNING LAMPS

Wiring Diagram — WARN — (Cont'd)

EL-WARN-06

: With 4-wheel drive

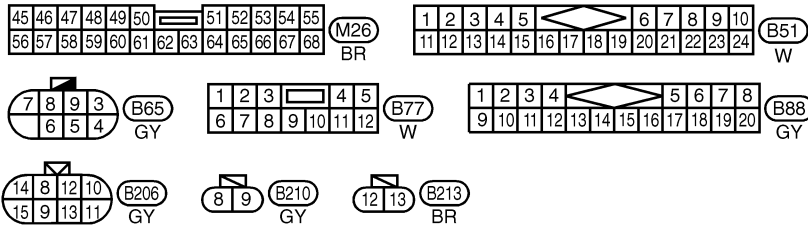
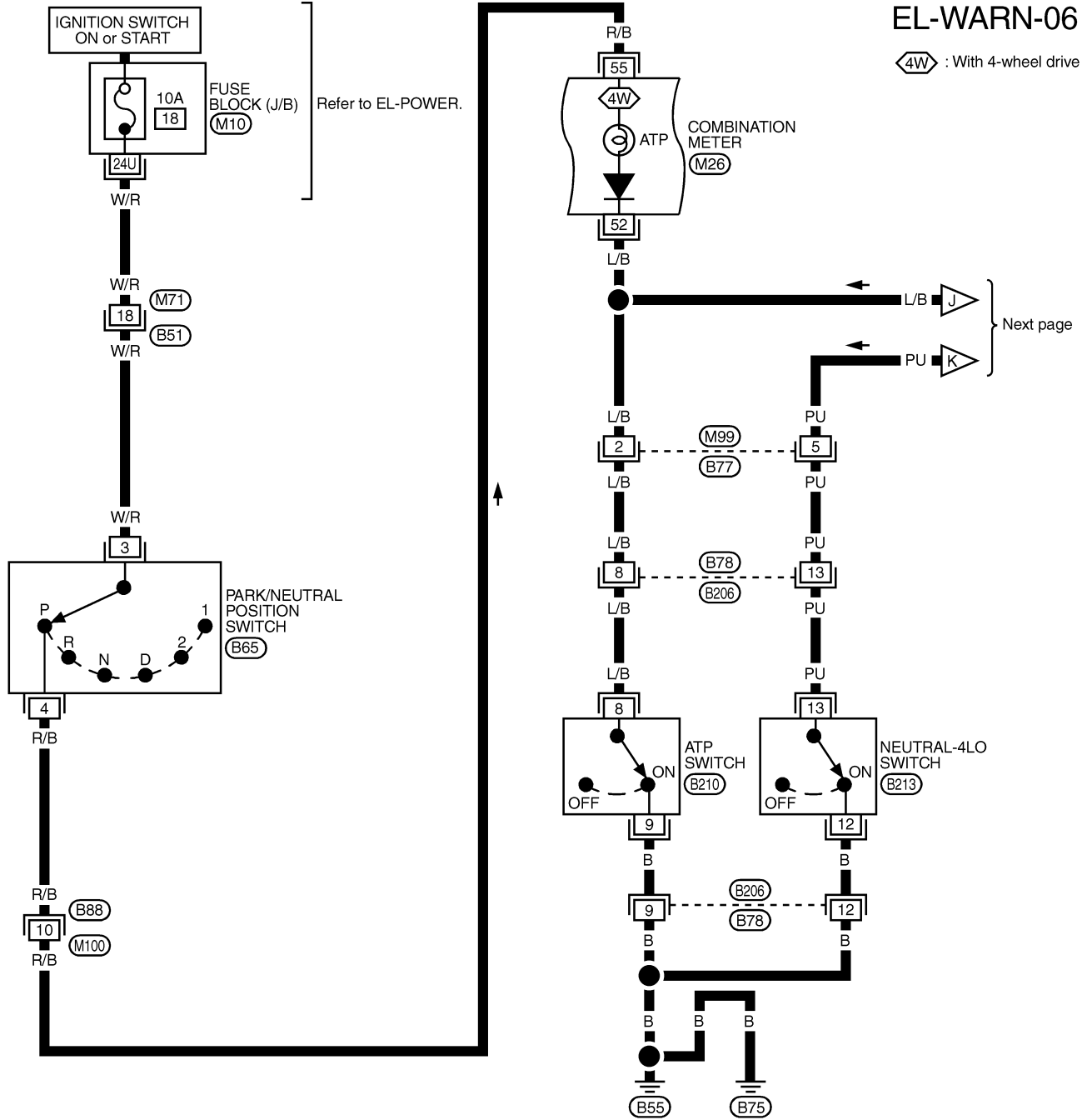

REFER TO THE FOLLOWING.

(M10) - FUSE BLOCK-
JUNCTION BOX (J/B)

MEL799L

WARNING LAMPS

Wiring Diagram — WARN — (Cont'd)

EL-WARN-07

4W : With 4-wheel drive

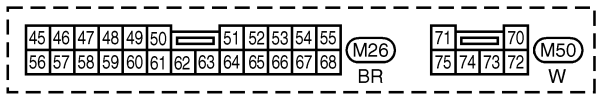
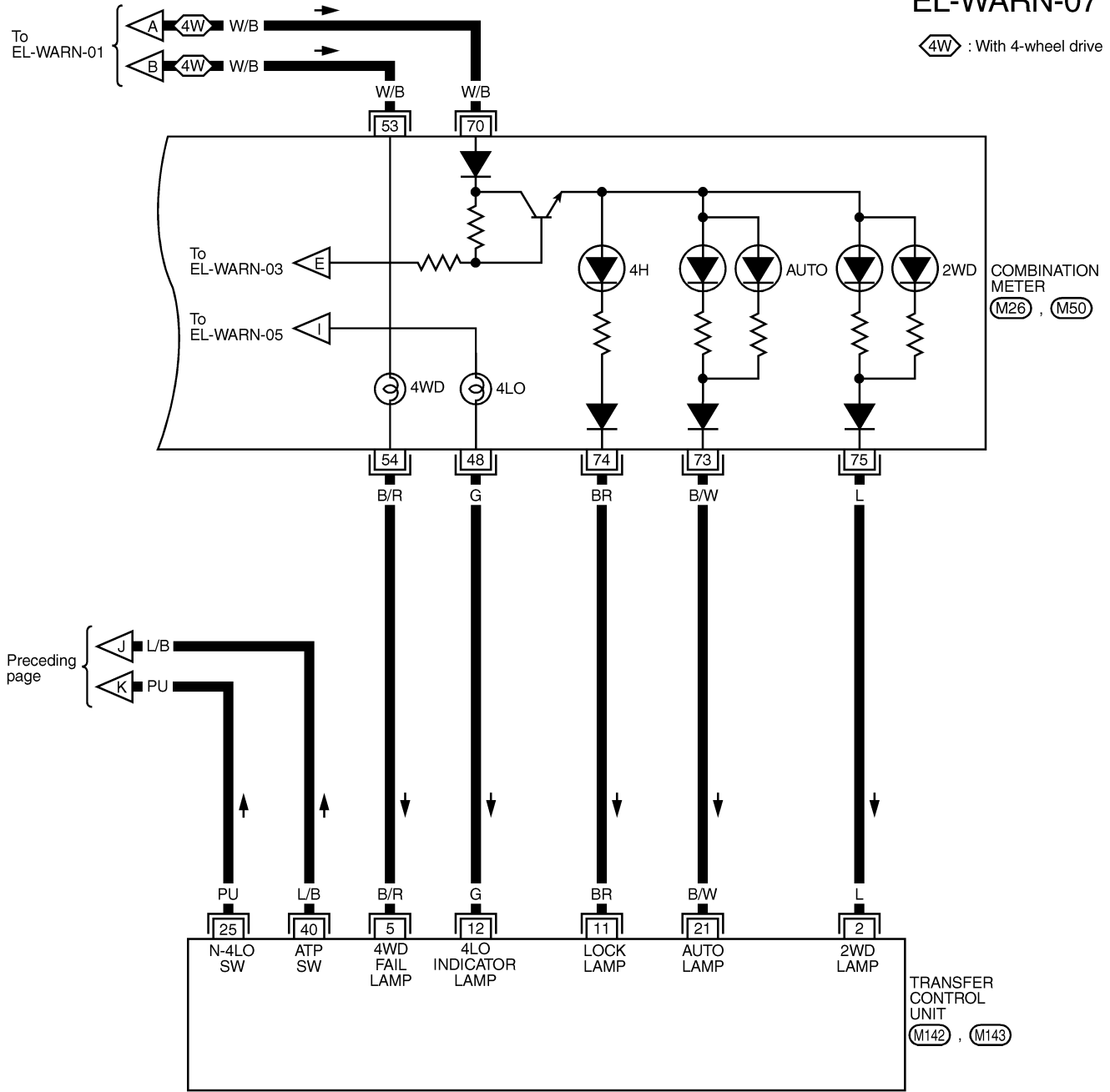

REFER TO THE FOLLOWING.
 (M142), (M143) -ELECTRICAL UNITS

GI
 MA
 EM
 LC
 EC
 FE
 AT
 TF
 PD
 AX
 SU
 BR
 ST
 RS
 BT
 HA
 SC
EL
 IDX

MEL800L

WARNING LAMPS

Fuel Warning Lamp Sensor Check

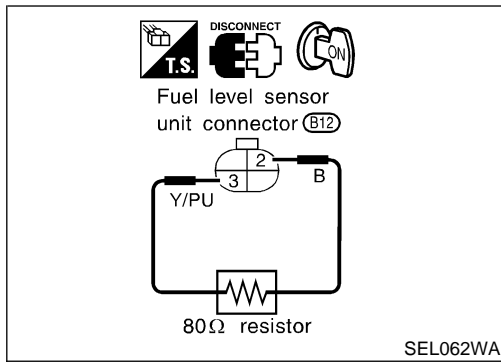

Fuel Warning Lamp Sensor Check

NBEL0166

1. Turn ignition switch "OFF".
2. Disconnect fuel level sensor unit harness connector B12.
3. Connect a resistor (80Ω) between fuel tank gauge unit harness connector terminals 2 and 3.
4. Turn ignition switch "ON".

The fuel warning lamp should come on.

NOTE:

ECM might store the 1st trip DTC P0180 during this inspection. If the DTC is stored in ECM memory, erase the DTC after reconnecting fuel tank gauge unit harness connector. Refer to EC-60, "HOW TO ERASE EMISSION-RELATED DIAGNOSTIC INFORMATION".

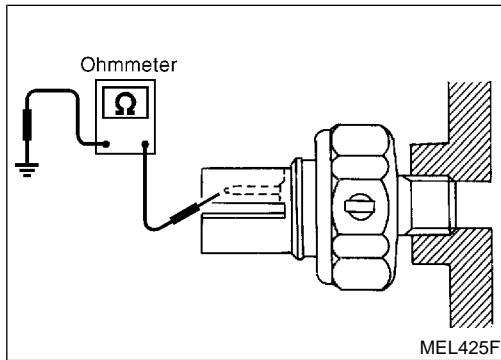

Electrical Components Inspection

NBEL0051

OIL PRESSURE SWITCH CHECK

NBEL0051S02

	Oil pressure kPa (kg/cm ² , psi)	Continuity
Engine start	More than 10 - 20 (0.1 - 0.2, 1 - 3)	NO
Engine stop	Less than 10 - 20 (0.1 - 0.2, 1 - 3)	YES

Check the continuity between the terminals of oil pressure switch and body ground.

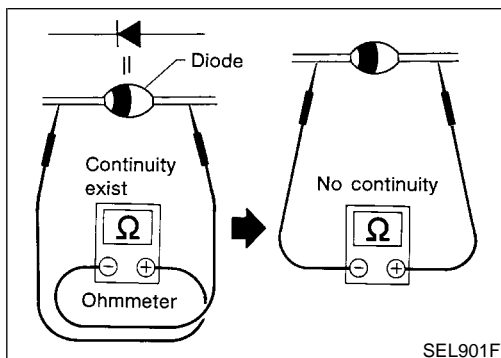

DIODE CHECK

NBEL0051S03

- Check continuity using an ohmmeter.
- Diode is functioning properly if test results are as shown in the figure at left.
- Check diodes at the combination meter harness connector instead of checking them on the combination meter assembly. Refer to EL-115, "WARNING LAMP" wiring diagrams.

NOTE:

Specification may vary depending on the type of tester. Before performing this inspection, be sure to refer to the instruction manual for the tester to be used.

A/T INDICATOR

Wiring Diagram — AT/IND —

Wiring Diagram — AT/IND —

NBEL0203

EL-AT/IND-01

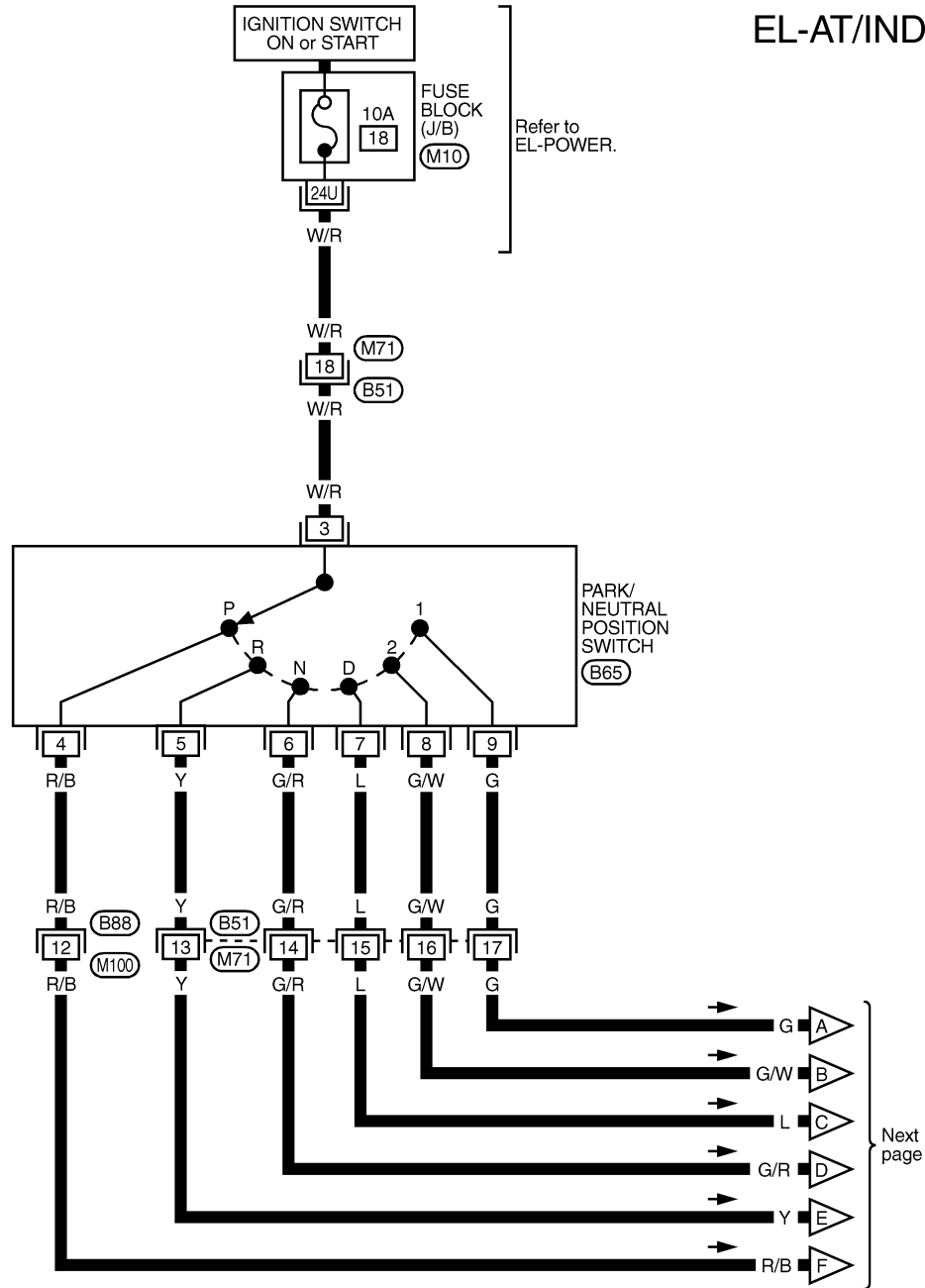

GI
MA
EM
LC
EC
FE
AT
TF
PD
AX
SU
BR
ST
RS
BT

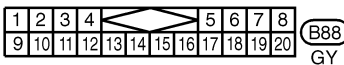
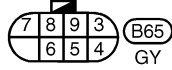

REFER TO THE FOLLOWING.

(M10) -FUSE BLOCK-
JUNCTION BOX (J/B)

HA
SC
EL
IDX

A/T INDICATOR

Wiring Diagram — AT/IND — (Cont'd)

EL-AT/IND-02

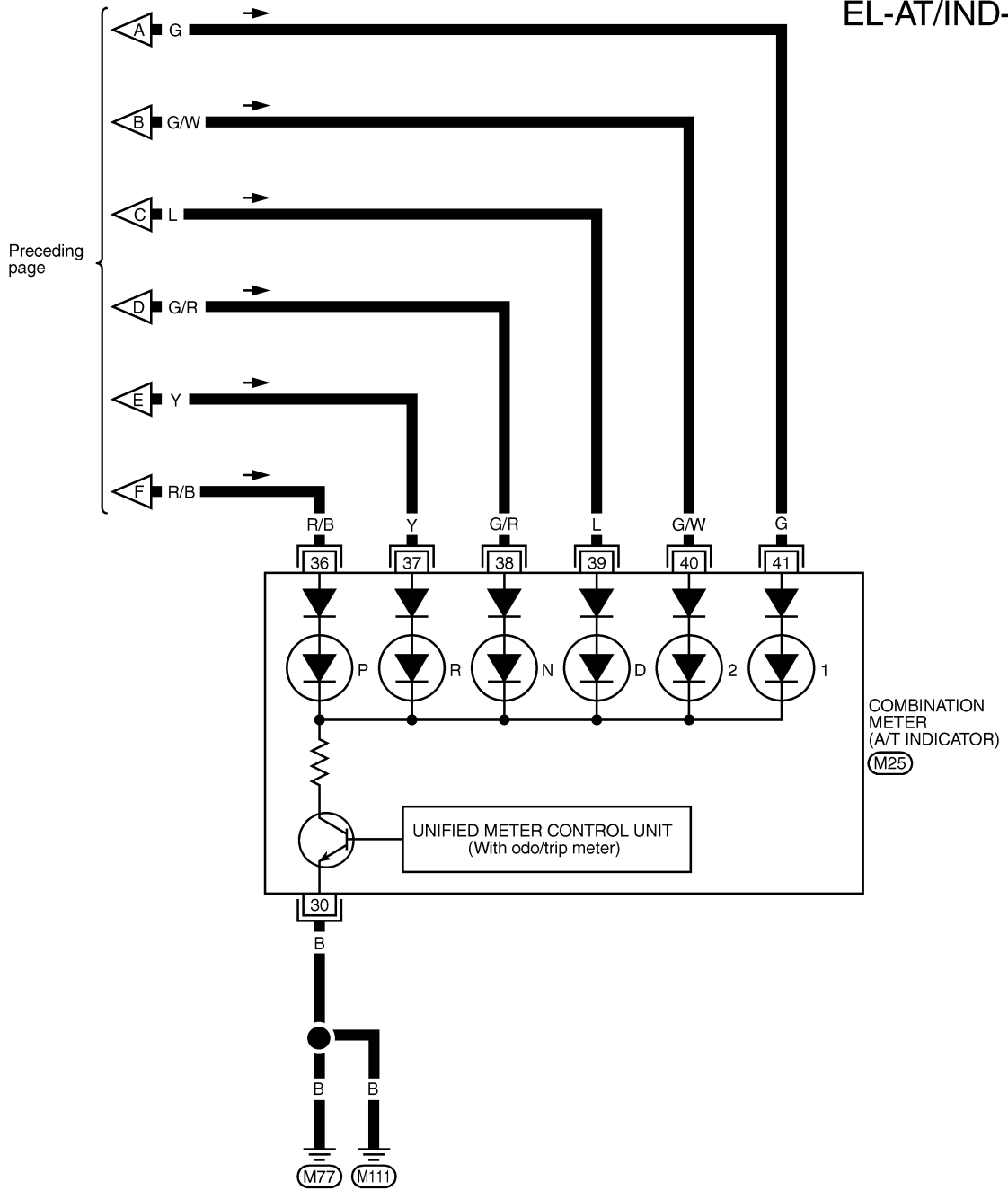

25	26	27	28	29	30	31	32	33	(M25)		
34	35	36	37	38	39	40	41	42	43	44	BR

MEL802L

WARNING CHIME

Component Parts and Harness Connector Location

Component Parts and Harness Connector Location

NBEL0052

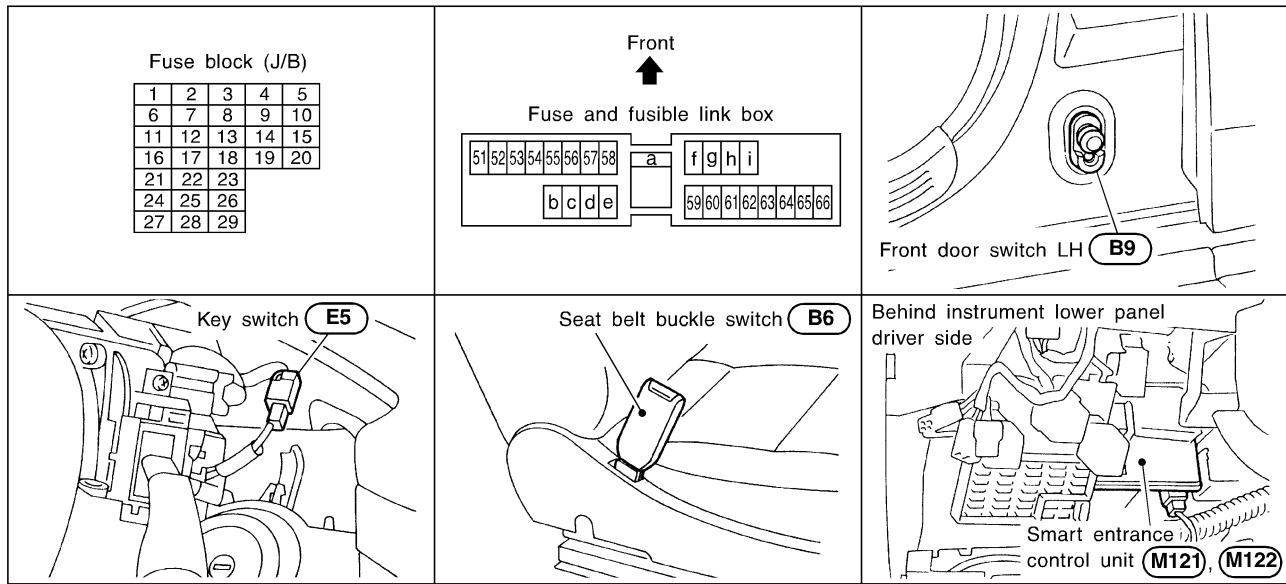

SEL046W

System Description

NBEL0053

The warning chime is controlled by the smart entrance control unit. The warning chime is located in the smart entrance control unit. Power is supplied at all times

- through 7.5A fuse [No. 24, located in the fuse block (J/B)]
- to smart entrance control unit terminal 10, and
- to key switch terminal 2, and
- through 10A fuse [No. 61, located in the fuse block (J/B)]
- to tail lamp relay terminals 2 and 3.

With the ignition switch in the ON or START position, power is supplied

- through 7.5A fuse [No. 11, located in the fuse block (J/B)]
- to smart entrance control unit terminal 33.

Ground is supplied to smart entrance control unit terminal 16 through body grounds M77 and M111.

IGNITION KEY WARNING CHIME

NBEL0053S01

With the key in the ignition switch in the OFF or ACC position, and the driver's door open, the warning chime will sound. Power is supplied

- from key switch terminal 1
- to smart entrance control unit terminal 32.

Ground is supplied

- from front door switch LH terminal 1
- to smart entrance control unit terminal 29.

Front door switch LH terminal 2 is grounded through body grounds B11, B22 and D210.

LIGHT WARNING CHIME

NBEL0053S02

With ignition switch OFF or ACC, driver's door open, warning chime will sound. [Except when headlamp battery saver control operates (for 45 seconds after ignition switch is turned to OFF or ACC position) and headlamps do not illuminate.] Power is supplied.

- from tail lamp relay terminal 5
- to smart entrance control unit terminal 34.

Ground is supplied

- from front door switch LH terminal 1

GI
MA
EM
LC
EC
FE
AT
TF
PD
AX
SU
BR
ST
RS
BT
HA
SC
EL
IDX

WARNING CHIME

System Description (Cont'd)

- to smart entrance control unit terminal 29.

Front door switch LH terminal 2 is grounded through body grounds B11, B22 and D210.

SEAT BELT WARNING CHIME

With ignition switch turned ON and seat belt unfastened (seat belt switch ON), warning chime will sound for approximately 6 seconds.

NBEL0053S03

Ground is supplied

- from seat belt switch terminal 1
- to smart entrance control unit terminal 22.

Seat belt switch terminal 2 is grounded through body grounds B11, B22 and D210.

WARNING CHIME

Wiring Diagram — CHIME —

Wiring Diagram — CHIME —

NBEL0054

EL-CHIME-01

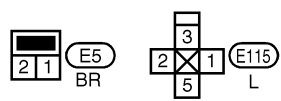
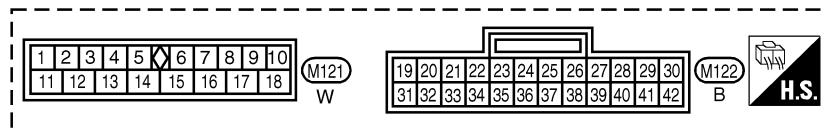
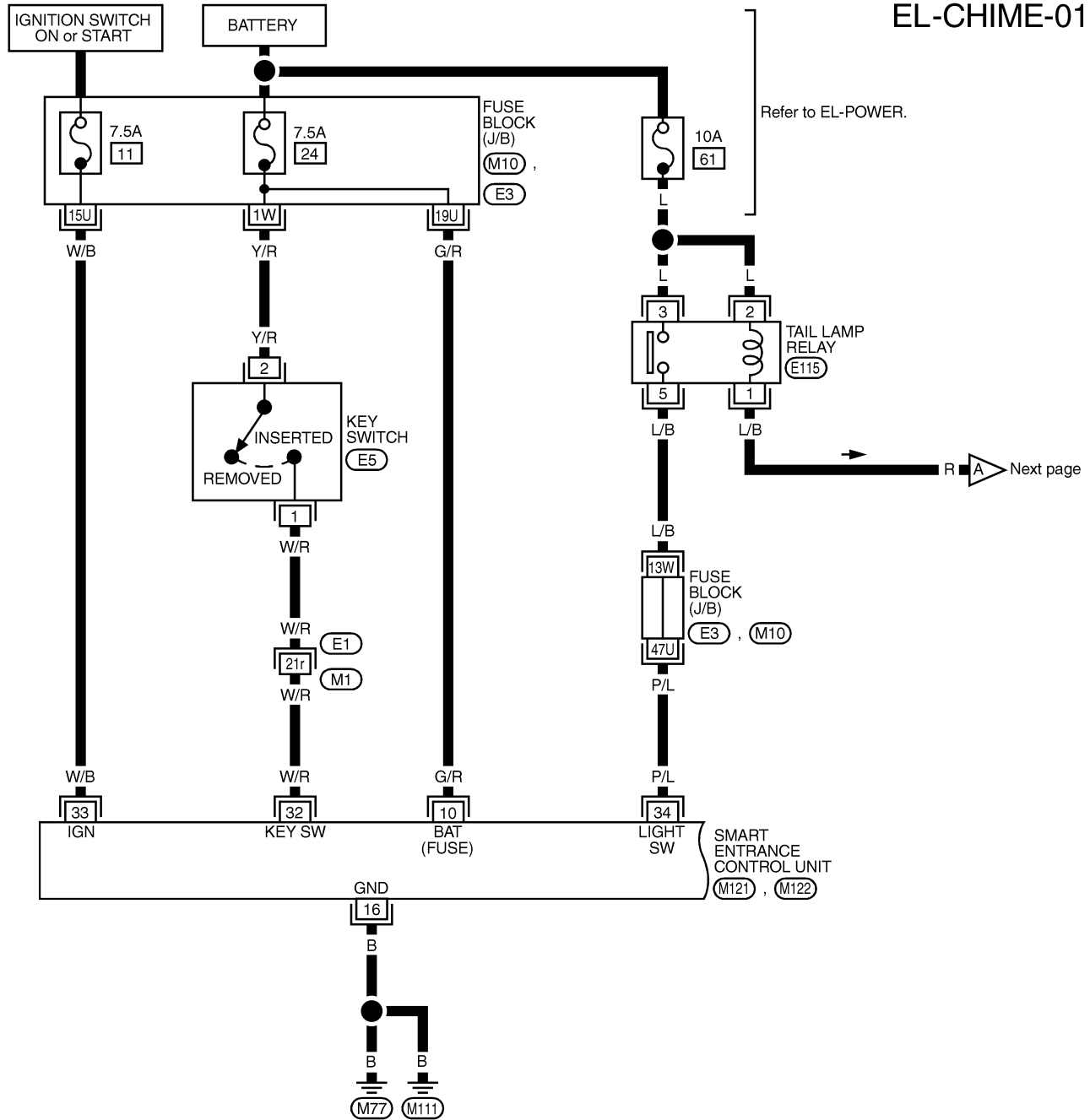

REFER TO THE FOLLOWING.
 (E1) - SUPER MULTIPLE JUNCTION (SMJ)
 (M10), (E3) - FUSE BLOCK - JUNCTION BOX (J/B)

GI
MA
EM
LC
EC
FE
AT
TF
PD
AX
SU
BR
ST
RS
BT
HA
SC
EL
IDX

WARNING CHIME

Wiring Diagram — CHIME — (Cont'd)

EL-CHIME-02

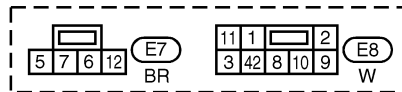
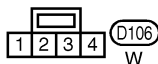
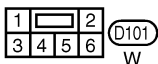
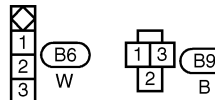
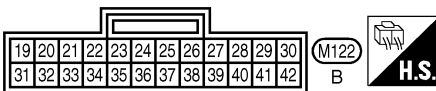
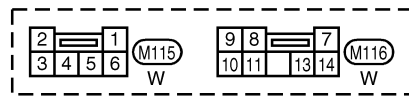
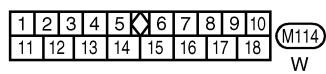
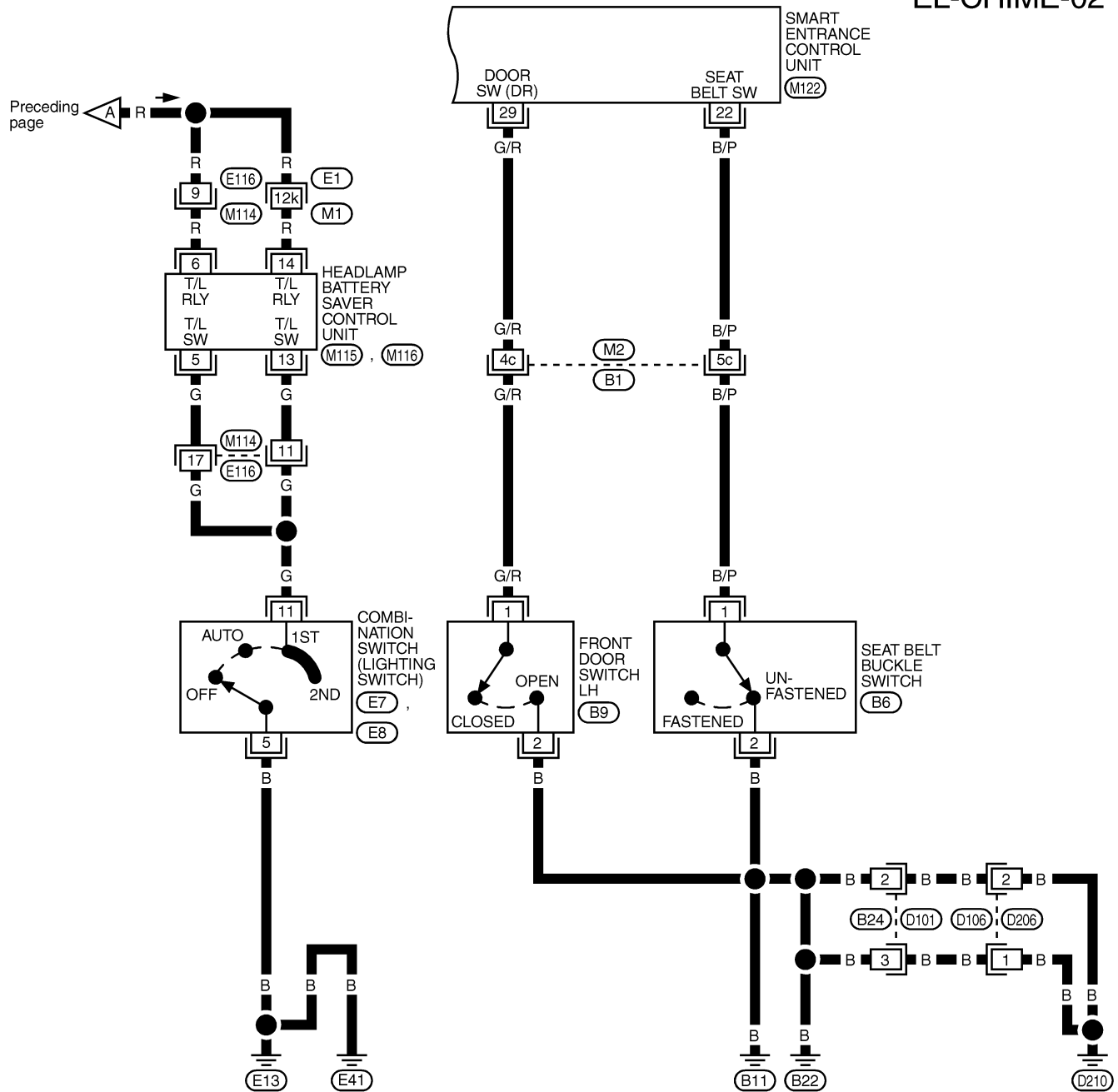

REFER TO THE FOLLOWING.

(E1), (B1) -SUPER MULTIPLE JUNCTION (SMJ)

MEL805L

WARNING CHIME

Trouble Diagnoses

Trouble Diagnoses SYMPTOM CHART

NBEL0055

NBEL0055S01

REFERENCE PAGE (EL-)	129	131	133	134	135
SYMPTOM	POWER SUPPLY AND GROUND CIRCUIT CHECK	LIGHTING SWITCH INPUT SIGNAL CHECK	KEY SWITCH (INSERT) CHECK	SEAT BELT BUCKLE SWITCH CHECK	DRIVER SIDE DOOR SWITCH CHECK
Light warning chime does not activate.	X	X			X
Ignition key warning chime does not activate.	X		X		X
Seat belt warning chime does not activate.	X			X	
All warning chimes do not activate.	X				

GI

MA

EM

LC

EC

FE

AT

TF

PD

AX

SU

BR

ST

RS

BT

HA

SC

EL

IDX

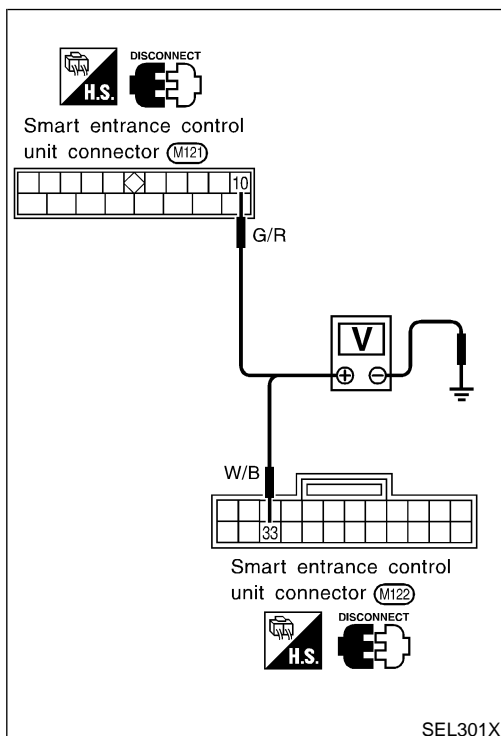

POWER SUPPLY AND GROUND CIRCUIT CHECK

NBEL0055S02

Power Supply Circuit Check

NBEL0055S0201

Terminals		Ignition switch position		
(+)	(-)	OFF	ACC	ON
10	Ground	Battery voltage	Battery voltage	Battery voltage
33	Ground	0V	0V	Battery voltage

WARNING CHIME

Trouble Diagnoses (Cont'd)

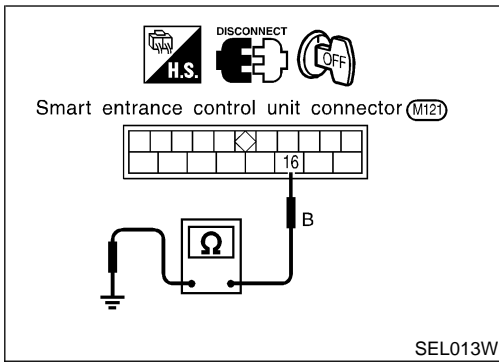

Ground Circuit Check

NBEL0055S0202

Terminals	Continuity
16 - Ground	Yes

WARNING CHIME

Trouble Diagnoses (Cont'd)

LIGHTING SWITCH INPUT SIGNAL CHECK

=NBEL0055S03

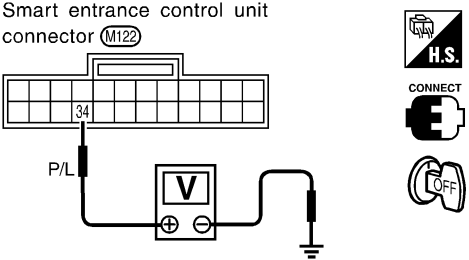
1	CHECK LIGHTING SWITCH INPUT SIGNAL	<p>Check voltage between smart entrance control unit terminal 34 and ground.</p> <div style="display: flex; justify-content: space-between; align-items: flex-start;"> <div style="width: 45%;">  </div> <div style="width: 50%; vertical-align: top;"> <p>Voltage [V]: Condition of lighting switch: 1ST or 2ND Approx. 12 Condition of lighting switch: OFF 0</p> </div> </div> <p style="text-align: right;">SEL377X</p>	GI MA EM LC EC FE AT
OK or NG			
OK	▶	Lighting switch is OK.	
NG	▶	GO TO 2.	

2	CHECK FUSE	<p>Is 10A fuse (No. 61, located in the fuse and fusible link box) OK?</p> <p style="text-align: center;">OK or NG</p>	TF PD AX
OK	▶	GO TO 3.	
NG	▶	Replace fuse.	

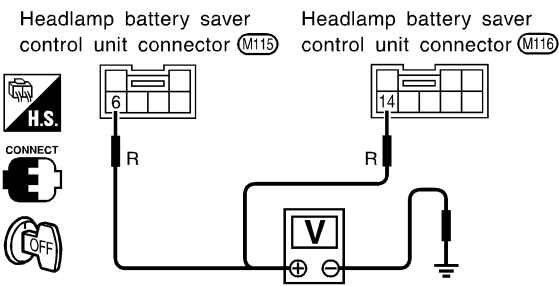

3	CHECK TAIL LAMP RELAY CIRCUIT	<p>Check voltage between headlamp battery saver control unit terminal 6, 14 and ground.</p> <div style="display: flex; justify-content: space-between; align-items: flex-start;"> <div style="width: 45%;">  </div> <div style="width: 50%; vertical-align: top;"> <p>Voltage [V]: Condition of lighting switch: 1ST or 2ND 0 Condition of lighting switch: OFF Approx. 12</p> </div> </div> <p style="text-align: right;">SEL378X</p>	SU BR ST RS BT HA SC
OK or NG			
OK	▶	<p>Check the following.</p> <ul style="list-style-type: none"> ● Tail lamp relay ● Harness for open or short between smart entrance control unit and tail lamp relay. 	
NG	▶	GO TO 4.	

EL

IDX

WARNING CHIME

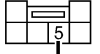
Trouble Diagnoses (Cont'd)

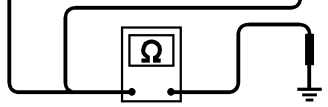
4	CHECK TAIL LAMP SWITCH GROUND CIRCUIT	
<p>1. Disconnect headlamp battery saver control unit connector.</p> <p>2. Check continuity between headlamp battery saver control unit terminal 5, 13 and ground.</p>		
<div style="display: flex; justify-content: space-between; align-items: flex-start;"> <div style="width: 45%;"> <p>Headlamp battery saver control unit connector (M115)</p>  </div> <div style="width: 45%;"> <p>Headlamp battery saver control unit connector (M116)</p>  </div> </div> <div style="display: flex; justify-content: space-between; align-items: center;"> <div style="width: 30%;">  </div> <div style="width: 40%; text-align: center;">  </div> <div style="width: 25%; padding-left: 20px;"> <p>Continuity:</p> <p>Condition of lighting switch: 1ST or 2ND</p> <p style="padding-left: 20px;">Yes</p> <p>Condition of lighting switch: OFF</p> <p style="padding-left: 20px;">No</p> </div> </div> <div style="text-align: right; margin-top: 10px;">SEL379X</div>		
OK or NG		
OK	▶	Check headlamp battery saver control unit. Refer to EL-42.
NG	▶	<p>Check the following.</p> <ul style="list-style-type: none"> ● Lighting switch ● Harness for open or short between headlamp battery saver control unit terminal 5, 13 and lighting switch terminal 11 ● Harness between lighting switch terminal 5 and ground

KEY SWITCH (INSERT) CHECK

=NBEL0055S04

1	CHECK KEY SWITCH INPUT SIGNAL	
<p>Check voltage between smart entrance control unit terminal 32 and ground.</p>		
<div style="display: flex; justify-content: space-between; align-items: flex-start;"> <div style="width: 45%;"> </div> <div style="width: 50%;"> <p>Voltage [V]: Condition of key switch: Key is inserted. Approx. 12 Condition of key switch: Key is removed. 0</p> </div> </div>		
SEL307X		
OK or NG		
OK	▶	Key switch is OK.
NG	▶	GO TO 2.

2	CHECK KEY SWITCH (INSERT)	
<p>Check continuity between terminals 1 and 2.</p>		
<div style="display: flex; justify-content: space-between; align-items: flex-start;"> <div style="width: 45%;"> </div> <div style="width: 50%;"> <p>Continuity: Condition of key switch: Key is inserted. Yes Condition of key switch: Key is removed. No</p> </div> </div>		
SEL308X		
OK or NG		
OK	▶	<p>Check the following.</p> <ul style="list-style-type: none"> ● 7.5A fuse [No. 24, located in fuse block (J/B)] ● Harness for open or short between key switch and fuse ● Harness for open or short between smart entrance control unit and key switch
NG	▶	Replace key switch.



GI
MA
EM
LC
EC
FE
AT
TF
PD
AX
SU
BR
ST
RS
BT
HA
SC
EL
IDX



WARNING CHIME

Trouble Diagnoses (Cont'd)

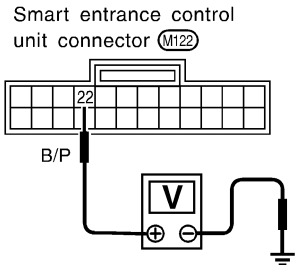
SEAT BELT BUCKLE SWITCH CHECK

=NBEL0055S05

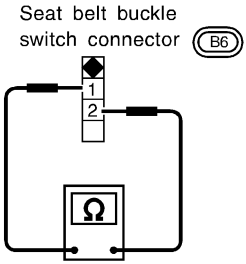
1	CHECK SEAT BELT BUCKLE SWITCH INPUT SIGNAL	
<p>1. Turn ignition switch "ON". 2. Check voltage between smart entrance control unit terminal 22 and ground.</p>		
<div style="display: flex; justify-content: space-between; align-items: flex-start;"> <div style="text-align: center;"> <p>Smart entrance control unit connector (M122)</p>  </div> <div style="text-align: center;">  </div> <div style="text-align: left;"> <p>Voltage [V]: Condition of seat belt buckle switch: Fastened Approx. 12 Condition of seat belt buckle switch: Unfastened 0</p> </div> </div>		
SEL380X		
OK or NG		
OK	▶	Seat belt buckle switch is OK.
NG	▶	GO TO 2.



2	CHECK SEAT BELT BUCKLE SWITCH	
Check continuity between terminals 1 and 2 when seat belt is fastened and unfastened.		
<div style="display: flex; justify-content: space-between; align-items: flex-start;"> <div style="text-align: center;"> <p>Seat belt buckle switch connector (B6)</p>  </div> <div style="text-align: center;">  </div> <div style="text-align: left;"> <p>Continuity: Seat belt is fastened. No Seat belt is unfastened. Yes</p> </div> </div>		
SEL381X		
OK or NG		
OK	▶	<p>Check the following.</p> <ul style="list-style-type: none"> ● Seat belt buckle switch ground circuit ● Harness for open or short between smart entrance control unit and seat belt buckle switch
NG	▶	Replace seat belt buckle switch.

WARNING CHIME

Trouble Diagnoses (Cont'd)

DRIVER SIDE DOOR SWITCH CHECK

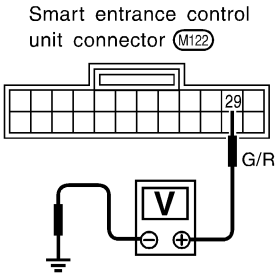
NBEL0055S06

1	CHECK DOOR SWITCH INPUT SIGNAL	<p>Check voltage between smart entrance control unit terminal 29 and ground.</p> <div style="display: flex; justify-content: space-around; align-items: center;"> <div style="text-align: center;">  <p>Smart entrance control unit connector (M122)</p> </div> <div style="text-align: center;">  </div> <div style="text-align: left;"> <p>Voltage [V]: Condition of driver's door: CLOSED Approx. 5 Condition of driver's door: OPENED 0</p> </div> </div> <p style="text-align: right;">SEL382X</p> <p style="text-align: center;">OK or NG</p>
	OK	▶ Front door switch LH is OK.
	NG	▶ GO TO 2.

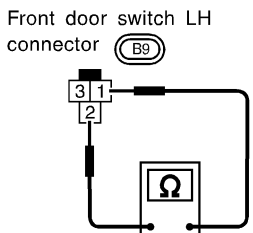
2	CHECK DRIVER SIDE DOOR SWITCH	<p>Check continuity between terminals 1 and 2.</p> <div style="display: flex; justify-content: space-around; align-items: center;"> <div style="text-align: center;">  </div> <div style="text-align: center;">  <p>Front door switch LH connector (B9)</p> </div> <div style="text-align: left;"> <p>Continuity: Door switch is pushed. No Door switch is released. Yes</p> </div> </div> <p style="text-align: right;">SEL383X</p> <p style="text-align: center;">OK or NG</p>
	OK	▶ Check the following. <ul style="list-style-type: none"> ● Door switch ground circuit ● Harness for open or short between smart entrance control unit and door switch
	NG	▶ Replace front door switch LH.

GI
MA
EM
LC
EC
FE
AT
TF
PD
AX
SU
BR
ST
RS
BT
HA
SC
EL
IDX

FRONT WIPER AND WASHER

System Description

System Description

NBEL0057

WIPER OPERATION

NBEL0057S01

The front wiper switch is controlled by a lever built into the combination switch. There are three wiper switch positions:

- LO speed
- HI speed
- INT (Intermittent)

With the ignition switch in the ACC or ON position, power is supplied

- through 20A fuse [No. 19, located in the fuse block (J/B)]
- to front wiper motor terminal 4, and
- to front wiper switch terminal 15.

Low and High Speed Wiper Operation

NBEL0057S0101

Ground is supplied to front wiper switch terminal 17 through body grounds E13 and E41.

When the wiper switch is placed in the LO position, ground is supplied

- through terminal 14 of the front wiper switch
- to front wiper motor terminal 3.

With power and ground supplied, the front wiper motor operates at low speed.

When the front wiper switch is placed in the HI position, ground is supplied

- through terminal 16 of the front wiper switch
- to front wiper motor terminal 1.

With power and ground supplied, the front wiper motor operates at high speed.

Auto Stop Operation

NBEL0057S0102

With front wiper switch turned OFF, front wiper motor will continue to operate until wiper arms reach windshield base.

When wiper arms are not located at base of windshield with front wiper switch OFF, ground is provided

- from terminal 14 of the front wiper switch
- to front wiper motor terminal 3, in order to continue front wiper motor operation at low speed.

Ground is also supplied

- to terminal 13 of the front wiper switch
- through front wiper motor terminal 2
- through terminal 6 of the front wiper motor, and
- through body grounds M77 and M111.

When wiper arms reach base of windshield, front wiper motor terminals 2 and 4 are connected instead of terminals 2 and 6. Wiper motor will then stop wiper arms at the PARK position.

Intermittent Operation

NBEL0057S0103

The front wiper motor operates the wiper arms one time at low speed at a set interval of approximately 2 to 13 seconds. This feature is controlled by the wiper amplifier built in the front wiper switch.

When the front wiper switch is placed in the INT position, ground is supplied

- to wiper amplifier (INT SW)
- from wiper switch terminal 17
- through body grounds E13 and E41, and
- to wiper motor terminal 3
- through the wiper switch terminal 14
- through wiper amplifier (OUTPUT)

WASHER OPERATION

NBEL0057S02

With the ignition switch in the ACC or ON position, power is supplied

- through 20A fuse [No. 19, located in the fuse block (J/B)]
- to washer motor terminal 1.

When the lever is pulled to the WASH position, ground is supplied

- to washer motor terminal 2
- through terminal 18 of the wiper switch

FRONT WIPER AND WASHER

System Description (Cont'd)

- through terminal 17 of the wiper switch, and
- through body grounds E13 and E41.

With power and ground supplied, the washer motor operates.

When the lever is pulled to the WASH position for one second or more, the wiper motor operates at low speed for approximately 3 seconds to clean windshield. This feature is controlled by the wiper amplifier in the same manner as the intermittent operation.

GI

MA

EM

LC

EC

FE

AT

TF

PD

AX

SU

BR

ST

RS

BT

HA

SC

EL

IDX

FRONT WIPER AND WASHER

Wiring Diagram — WIPER —

Wiring Diagram — WIPER —

NBEL0058

EL-WIPER-01

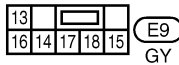
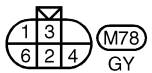
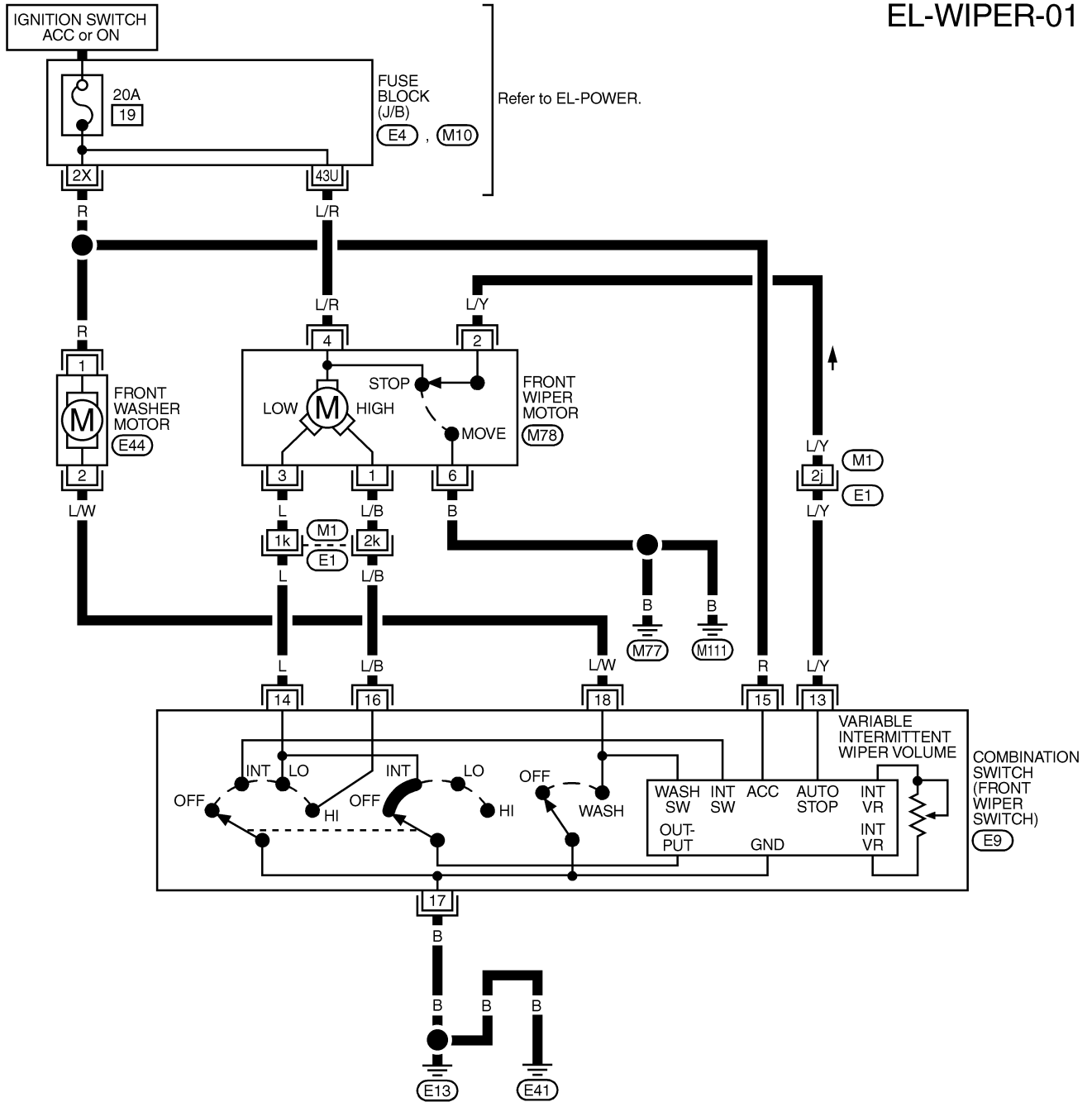

REFER TO THE FOLLOWING.
 (E1) -SUPER
 MULTIPLE JUNCTION (SMJ)
 (M10) , (E4) -FUSE BLOCK-
 JUNCTION BOX (J/B)

MEL806L

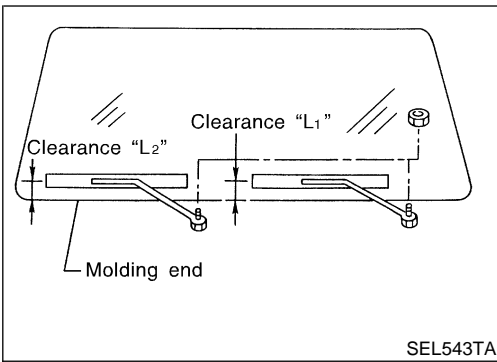

Removal and Installation

NBEL0060

WIPER ARMS

NBEL0060S01

1. Prior to wiper arm installation, turn on wiper switch to operate wiper motor and then turn it "OFF" (Auto Stop).
2. Lift the blade up and then set it down onto glass surface to set the blade center to clearance "L₁" & "L₂" immediately before tightening nut.
3. Eject washer fluid. Turn on wiper switch to operate wiper motor and then turn it "OFF".
4. Ensure that wiper blades stop within clearance "L₁" & "L₂".

Clearance "L₁": 29 - 30 mm (1.14 - 1.18 in)

Clearance "L₂": 32 - 42 mm (1.26 - 1.65 in)

- Tighten wiper arm nuts to specified torque.

Front wiper: 21 - 26 N·m (2.1 - 2.7 kg-m, 15 - 20 ft-lb)

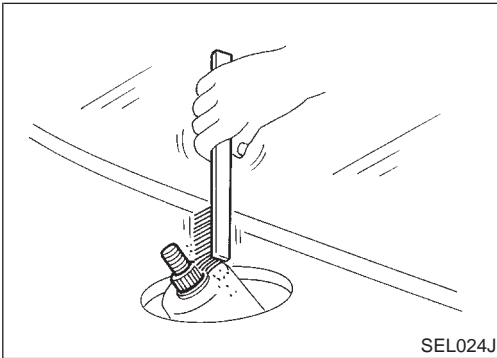

- Before reinstalling wiper arm, clean up the pivot area as illustrated. This will reduce possibility of wiper arm looseness.

WIPER LINKAGE

NBEL0060S02

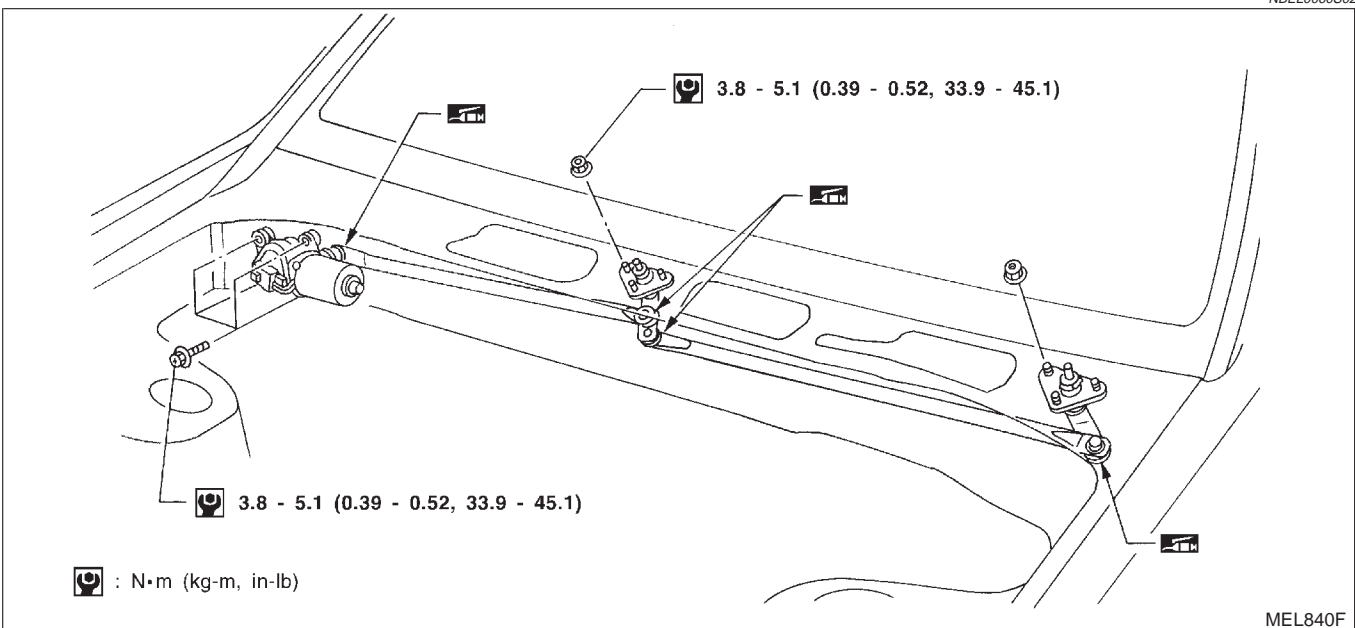

GI
MA
EM
LC
EC
FE
AT
TF
PD
AX
SU
BR
ST
RS
BT
HA
SC
EL
IDX

FRONT WIPER AND WASHER

Removal and Installation (Cont'd)

Removal

NBEL0060S0201

1. Remove 4 bolts that secure wiper motor.
2. Detach wiper motor from wiper linkage at ball joint.
3. Remove wiper linkage.

Be careful not to break ball joint rubber boot.

Installation

NBEL0060S0202

- Grease ball joint portion before installation.
1. Installation is the reverse order of removal.

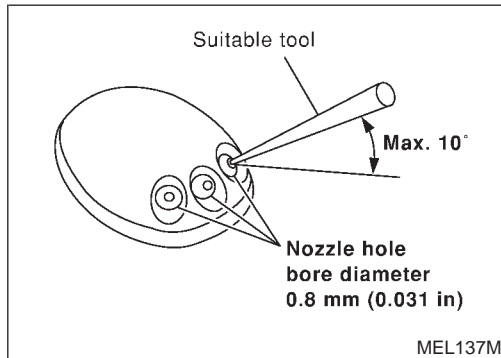

Washer Nozzle Adjustment

NBEL0061

- Adjust washer nozzle with suitable tool as shown in the figure at left.

Adjustable range: ±10°

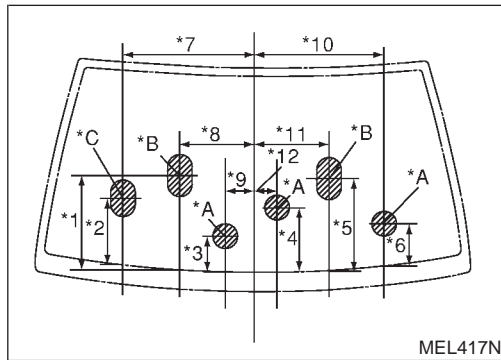

Unit: mm (in)

*1	315 (12.40)	*7	443 (17.44)
*2	227 (8.94)	*8	250 (9.84)
*3	122 (4.80)	*9	80 (3.15)
*4	220 (8.66)	*10	430 (16.93)
*5	315 (12.40)	*11	250 (9.84)
*6	145 (5.71)	*12	57 (2.24)

*A: The diameters of these circles are less than 80 mm (3.15 in).

*B: The diameter of this circle is less than 120 × 80 mm (4.72 × 3.15 in).

*C: The diameter of this circle is less than 100 × 80 mm (3.94 × 3.15 in).

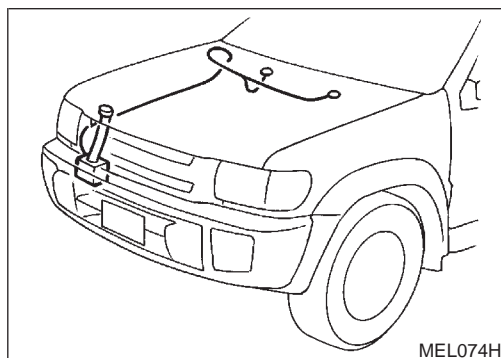

Washer Tube Layout

NBEL0062

System Description

WIPER OPERATION

NBEL0063

Power Supply and Ground

NBEL0063S01

GI

With ignition switch in the ACC or ON position, power is supplied

- through 10A fuse [No. 29, located in the fuse block (J/B)]
- to rear wiper amp. terminal 6.

MA

When the glass hatch switch is OPEN, ground is supplied

- to rear wiper amp. terminal 3
- through glass hatch switch terminal 1 and 2
- through body grounds B11, B22 and D210.

EM

Ground is supplied

- to rear wiper amp. terminal 9
- through body grounds B11, B22 and D210.

LC

EC

Low Speed Wiper Operation

NBEL0063S0103

FE

When the rear wiper switch is turned ON, ground is supplied

- to rear wiper amp. terminal 2
- through combination switch terminals 22 and 24.
- through body grounds E13 and E41

AT

Then, power is supplied

- through rear wiper amp. terminal 11
- to rear wiper motor terminal 4.

TF

Ground is supplied

- to rear wiper motor terminal 3
- through rear wiper amp. terminal 8.

PD

AX

With power and ground supplied, the wiper motor operates at low speed.

Auto Stop Operation

NBEL0063S0104

SU

With rear wiper switch turned OFF, rear wiper motor will continue to operate until wiper arm reaches rear wiper stopper.

When rear wiper arm is not located at rear wiper stopper with wiper switch OFF, ground is supplied

- to rear wiper amp. terminal 10
- through wiper motor terminals 7 and 8
- through body grounds B11, B22 and D210.

BR

Then rear wiper motor continues to operate until wiper arm reaches bottom.

When wiper arm reaches bottom, power is supplied

- through 10A fuse [No. 29, located in the fuse block (J/B)]
- through rear wiper motor terminals 6 and 7 and
- through rear wiper amp. terminals 10 and 8
- to rear wiper motor terminal 3.

ST

RS

BT

Ground is supplied

- to rear wiper motor 4
- through rear wiper amp. terminal 11.

HA

SC

Then wiper motor turns the other way and wiper arm moves once until wiper arm reaches stopper.

Intermittent Operation

NBEL0063S0105

EL

The rear wiper motor operates the wiper arms at low speed approximately every 7 seconds. This feature is controlled by the wiper amp.

When the wiper switch is placed in the INT position, ground is supplied

- to wiper amp. terminal 4
- through rear combination switch terminal 21 and 24
- through body grounds E13 and E41.

IDX

Then, power is supplied

- through rear wiper amp. terminal 11

REAR WIPER AND WASHER

System Description (Cont'd)

- to rear wiper motor terminal 4.

Ground is supplied

- to rear wiper motor terminal 3
- through rear wiper amp. terminal 8.

With power and ground supplied, rear wiper operates at low speed intermittent.

WIPER OPERATION PROHIBIT CONTROL

When glass hatch is open with back door key cylinder while rear wiper is operated, wiper operation is stopped. NBEL0063S03
(Wiper operation prohibit control)

When glass hatch is closed and rear wiper switch turns from OFF and then rear wiper switch is turned to ON, wiper operation prohibit control is canceled.

WASHER OPERATION

When the rear wiper switch is turned to WASH position, ground is supplied NBEL0063S02

- to rear wiper amp. terminal 1
- through terminals 23 and 24
- through body grounds E13 and E41.

Then, power is supplied

- through rear wiper amp. terminal 7
- to rear washer motor terminal 2.

Ground is supplied

- to rear washer motor terminal 1
- through body grounds E13 and E41.

With power and ground supplied, the rear washer motor operates.

When the rear wiper switch is turned to WASH position for one second or more, the rear wiper motor operates at low speed for approximately 3 seconds after the rear wiper switch is released. This feature is controlled by the rear wiper amp. in the same manner as the low speed operation.

REAR WIPER AND WASHER

Wiring Diagram — WIP/R —

Wiring Diagram — WIP/R —

NBEL0065

EL-WIP/R-01

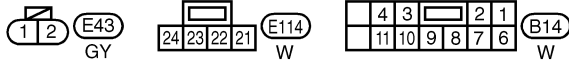
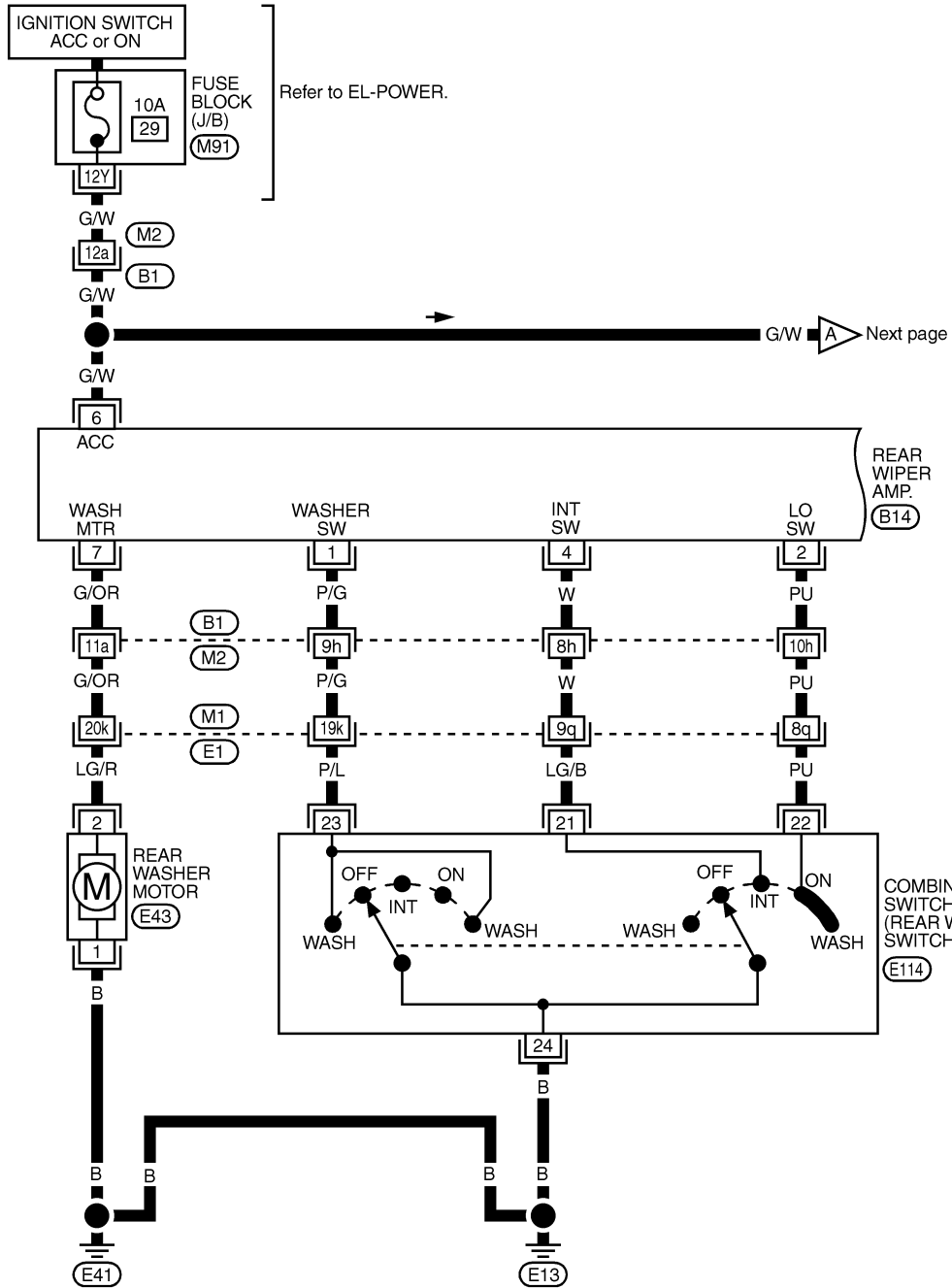

REFER TO THE FOLLOWING.

(B1), (E1) -SUPER MULTIPLE JUNCTION (SMJ)

(M91) -FUSE BLOCK-JUNCTION BOX (J/B)

GI

MA

EM

LC

EC

FE

AT

TF

PD

AX

SU

BR

ST

RS

BT

HA

SC

EL

IDX

MEL809L

REAR WIPER AND WASHER

Wiring Diagram — WIP/R — (Cont'd)

EL-WIP/R-02

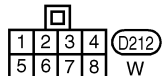
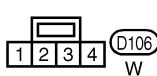
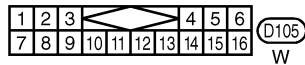
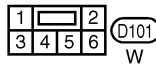
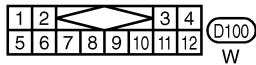
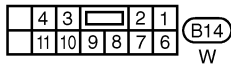
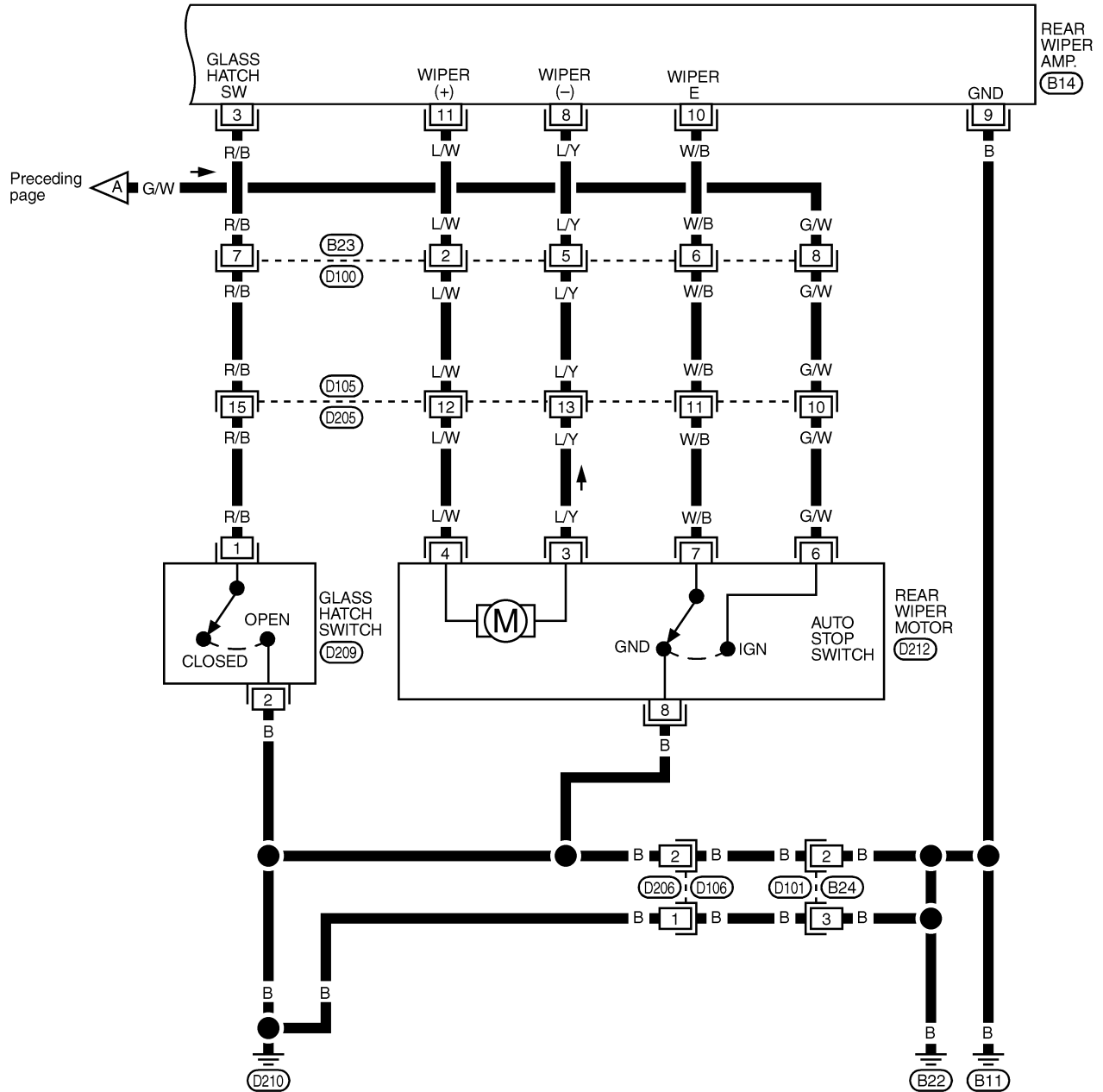

MEL810L









Trouble Diagnoses

REAR WIPER AMP. INSPECTION TABLE

(Data are reference values.)

NBEL0066

NBEL0066S01

Terminal No.	Item		Condition	Voltage (Approximate value)	
1	Washer switch		Rear wiper switch	WASH	Less than 1V
				OFF, ON or INT	Battery voltage
2	Low switch		Rear wiper switch	ON	Less than 1V
				OFF or INT	Battery voltage
3	Glass hatch switch		Glass hatch	Open	Less than 1V
				Closed	Battery voltage
4	Intermittent switch		Rear wiper switch	INT	Less than 1V
				OFF, ON or WASH	Battery voltage
6	Power supply (ACC)		—	Battery voltage	
7	Washer motor		Rear washer switch	WASH	Battery voltage
				OFF, ON or INT	Less than 1V
8	Rear wiper motor		Wiper is moving (except final drive)	Less than 1V	
			Wiper stop	Less than 1V	
			During wiper final drive	Battery voltage	
9	Ground	—	—	—	
10	Auto stop switch		Rear wiper switch should be at "INT" to inspect the value for wiper movement.	Wiper is moving	Less than 1V
				Wiper stop	Battery voltage
11	Rear wiper motor		Wiper is moving (except final drive)	Battery voltage	
			Wiper stop	Battery voltage	
			During wiper final drive	Less than 1V	

NOTE:

Power to the rear wiper amp. will be interrupted when the rear glass hatch is opened. In that case, conduct the inspection of the rear wiper amp. with the rear glass hatch closed, unless otherwise indicated.

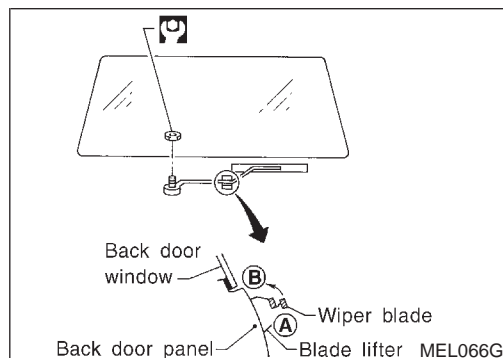

Removal and Installation

WIPER ARMS

NBEL0067

NBEL0067S01

1. Prior to wiper arm installation, turn on wiper switch to operate wiper motor and then turn it "OFF" (Auto Stop).
2. Install wiper arm to portion A as in figure below and tighten wiper arm nut to specification.
3. Then, set wiper arm to portion B.

 : 13 - 18 N·m (1.3 - 1.8 kg·m, 9 - 13 ft·lb)

REAR WIPER AND WASHER

Removal and Installation (Cont'd)

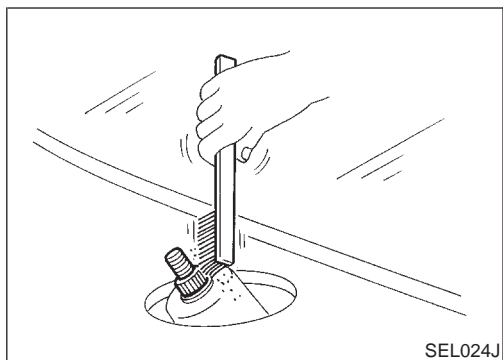

- Before reinstalling wiper arm, clean up the pivot area as illustrated. This will reduce possibility of wiper arm looseness.

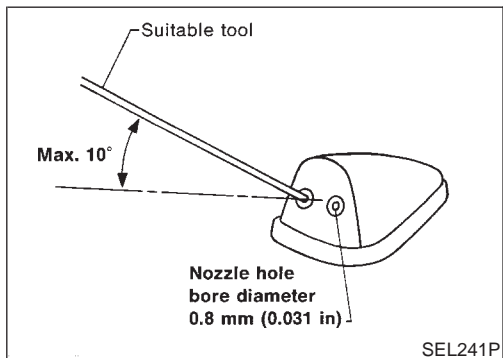

Washer Nozzle Adjustment

- Adjust washer nozzle with suitable tool as shown in the figure at left. NBEL0068

Adjustable range: ±10° (In any direction)

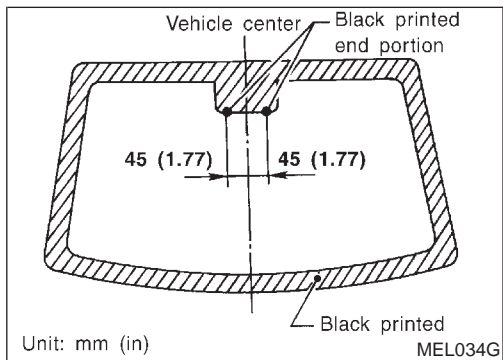

Washer Tube Layout

NBEL0069

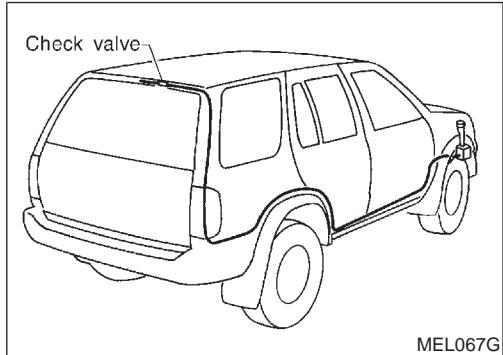

Check Valve

- A check valve is provided in the washer fluid line. Be careful not to connect check valve to washer tube in the wrong direction. NBEL0070

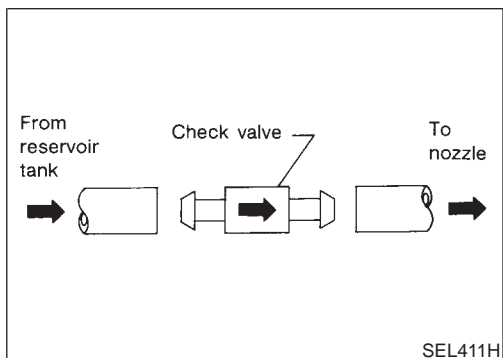

Wiring Diagram — HORN —

NBEL0071

EL-HORN-01

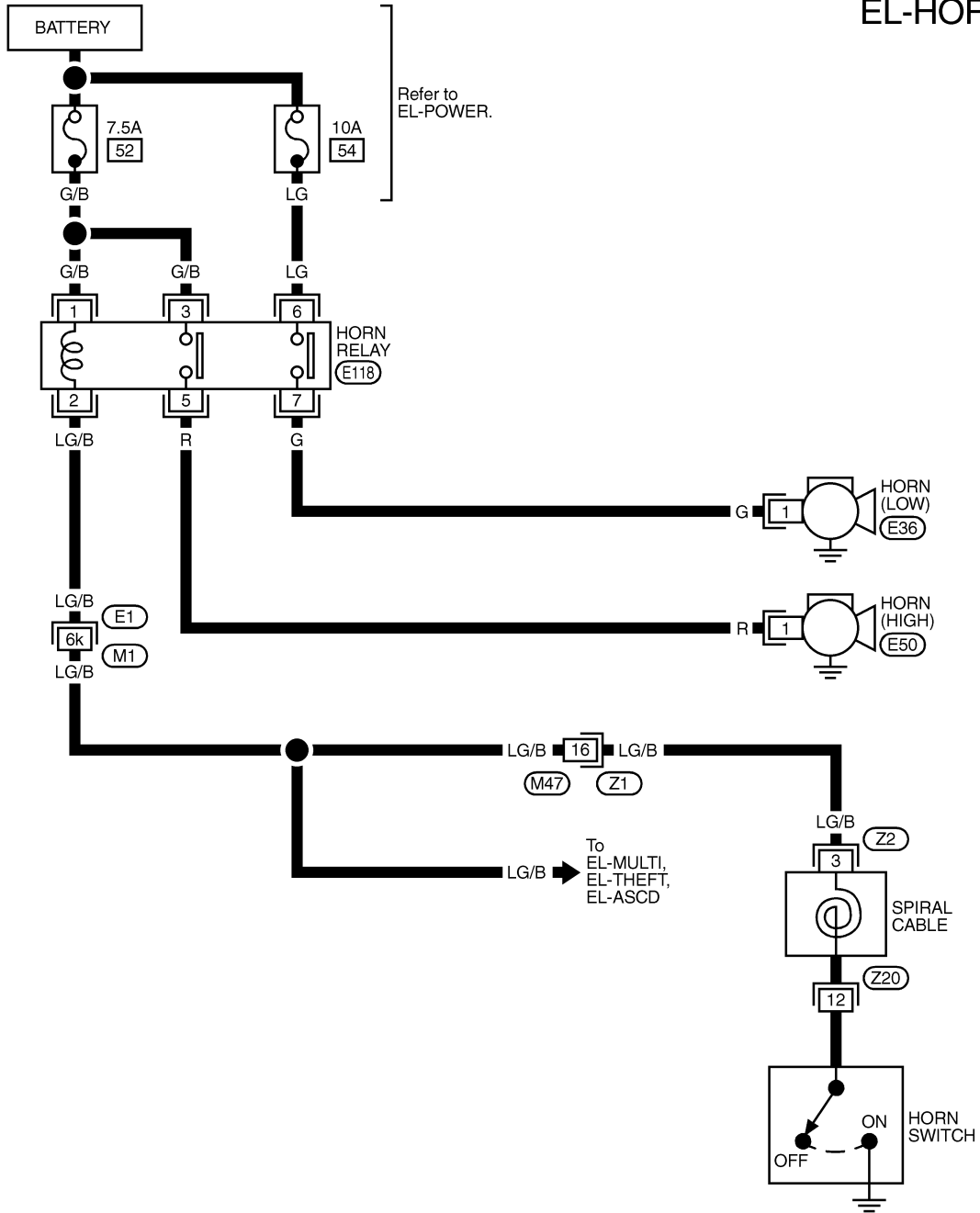

GI
MA
EM
LC
EC
FE
AT
TF
PD
AX
SU
BR
ST
RS
BT
HA
SC
EL
IDX

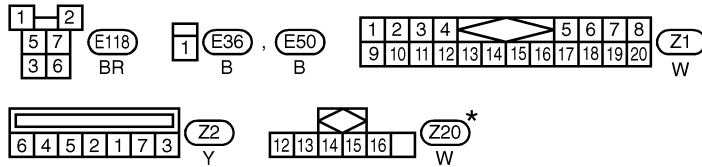

* : This connector is not shown in "HARNES LAYOUT", EL section.

REFER TO THE FOLLOWING.
(E1) -SUPER
MULTIPLE JUNCTION (SMJ)

CIGARETTE LIGHTER

Wiring Diagram — CIGAR —

Wiring Diagram — CIGAR —

NBEL0156

EL-CIGAR-01

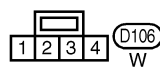
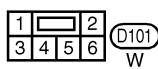
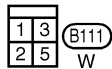
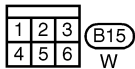
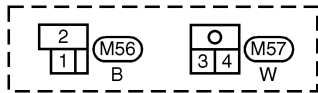
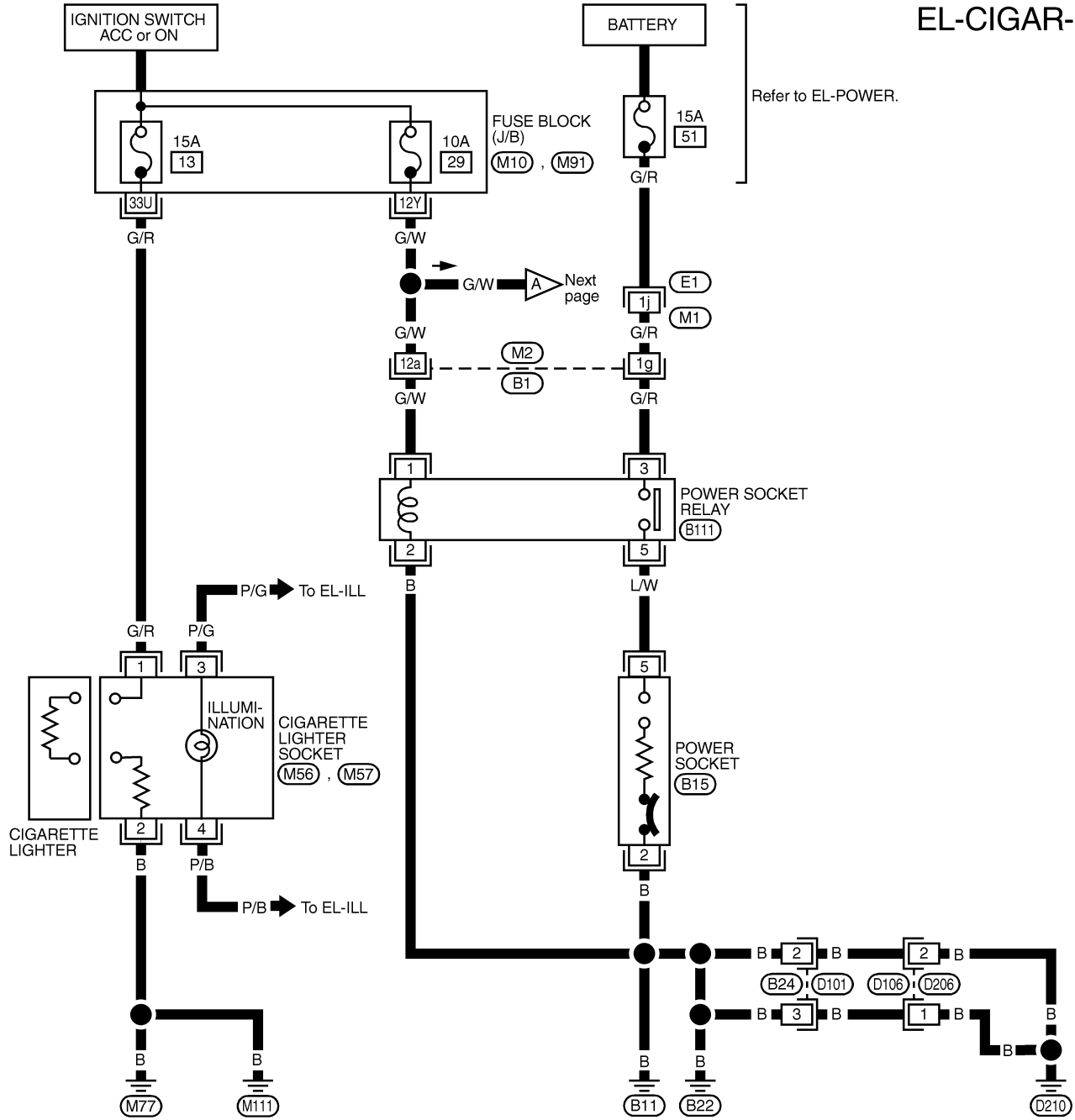

REFER TO THE FOLLOWING.

(E1) , (B1) - SUPER MULTIPLE

JUNCTION (SMJ)

(M10) , (M91) - FUSE BLOCK -
JUNCTION BOX (J/B)

MEL812L

CIGARETTE LIGHTER

Wiring Diagram — CIGAR — (Cont'd)

EL-CIGAR-02

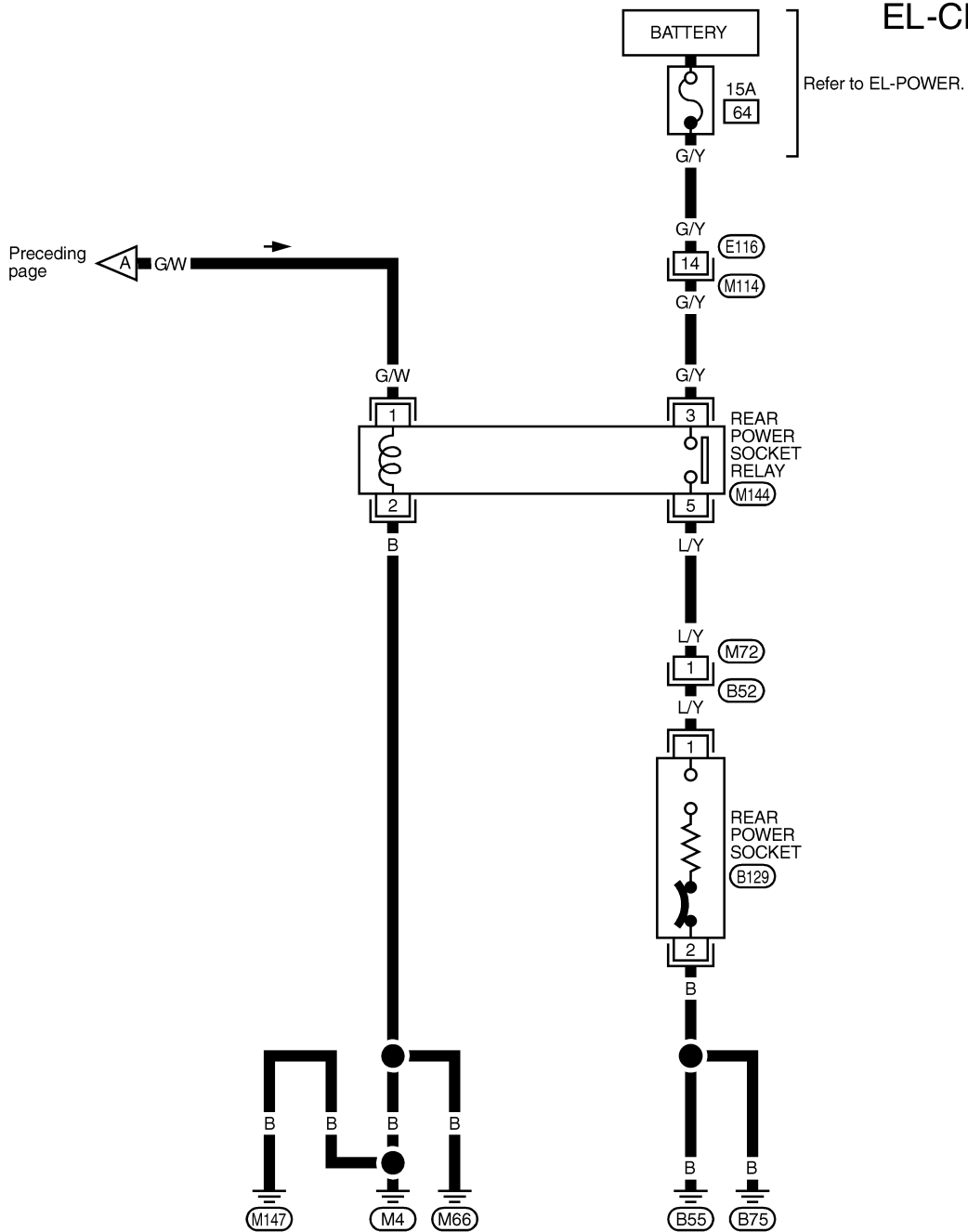

Refer to EL-POWER.

Preceding page

1	2	3	4	5	6	7	8	9	10
11	12	13	14	15	16	17	18		

(M114)
W

1	3
2	5

(M144)
W

1	2	3	4	5	6	7
8	9	10	11	12	13	14

(B52)
W

2
1

(B129)
B

GI
MA
EM
LC
EC
FE
AT
TF
PD
AX
SU
BR
ST
RS
BT
HA
SC
EL
IDX

MEL813L

CLOCK

Wiring Diagram — CLOCK —

Wiring Diagram — CLOCK —

NBEL0204

EL-CLOCK-01

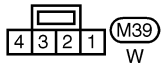
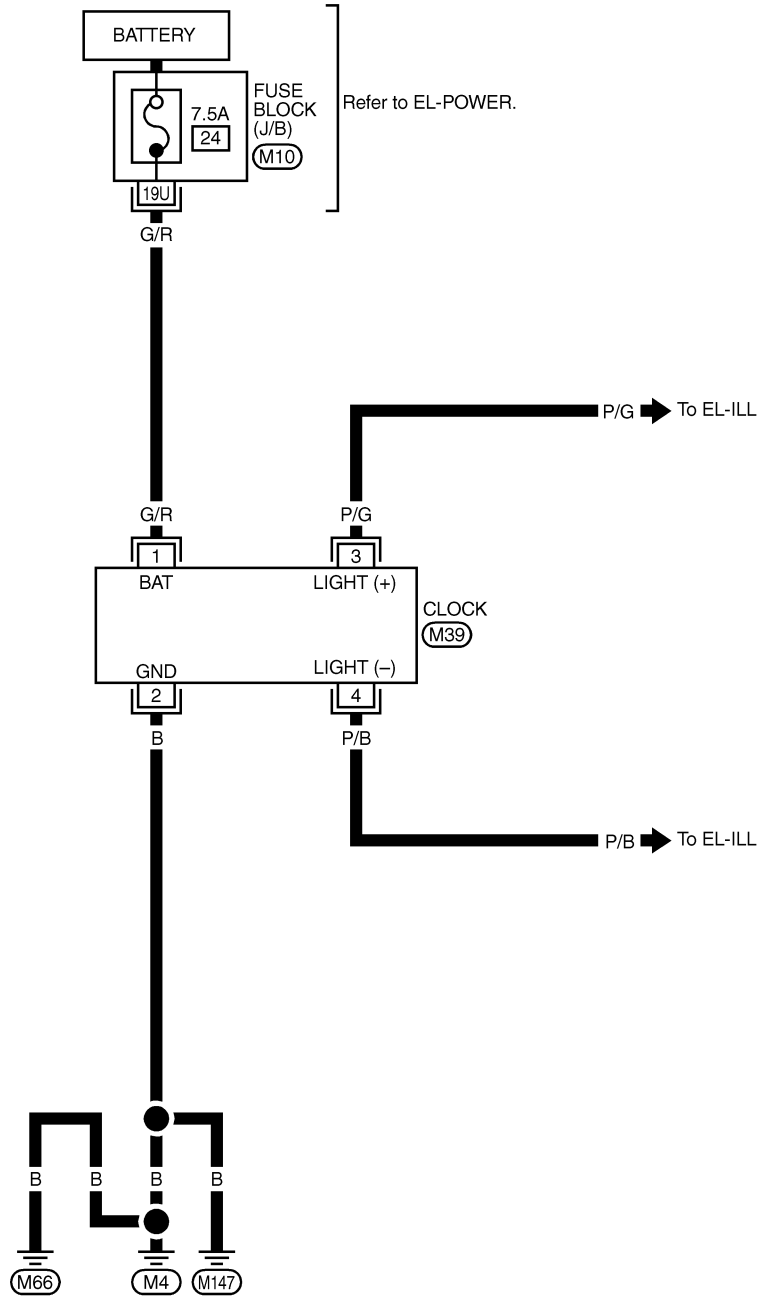

REFER TO THE FOLLOWING.

(M10) -FUSE BLOCK-
JUNCTION BOX (J/B)

MEL814L

REAR WINDOW DEFOGGER

Component Parts and Harness Connector Location

Component Parts and Harness Connector Location

NBEL0072

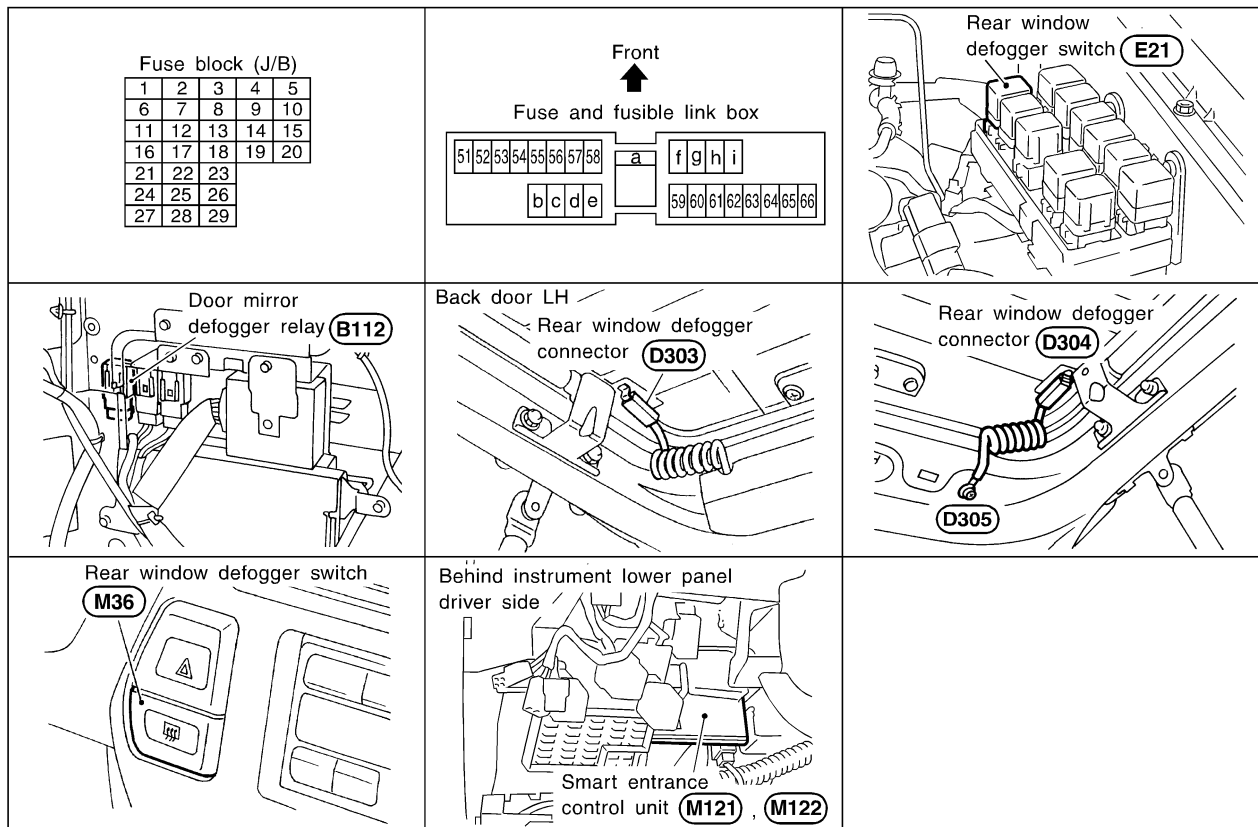

SEL465X

System Description

NBEL0073

The rear window defogger system is controlled by the smart entrance control unit. The rear window defogger operates only for approximately 15 minutes.

Power is supplied at all times

- to rear window defogger relay terminal 3
- through 20A fuse (No. 56, located in the fuse and fusible link box) and
- to rear window defogger relay terminal 6
- through 20A fuse (No. 57, located in the fuse and fusible link box)
- to smart entrance control unit terminal 10
- through 7.5A [No. 24, located in fuse block (J/B)]

With the ignition switch in the ON or START position, power is supplied

- through 7.5A fuse [No. 11, located in the fuse block (J/B)]
- to the rear window defogger relay terminal 1, and
- to smart entrance control unit terminal 33.

Ground is supplied

- to terminal 1 of the rear window defogger switch
- through body grounds M4, M66 and M147 (with navigation system),
- to terminal 32 of the A/C auto amp.
- through body grounds M4, M66 and M147 (without navigation system), or
- to smart entrance control unit terminal 16
- through body grounds M77 and M111.

GI

MA

EM

LC

EC

FE

AT

TF

PD

AX

SU

BR

ST

RS

BT

HA

SC

EL

IDX

REAR WINDOW DEFOGGER

System Description (Cont'd)

When the rear window defogger switch is turned ON, ground is supplied

- through terminal 2 of the rear window defogger switch (with navigation system), or
- through terminal 31 of A/C auto amp. (without navigation system)
- to smart entrance control unit terminal 39.

Terminal 2 of the smart entrance control unit then supplies ground to the rear window defogger relay terminal 2.

With power and ground supplied, the rear window defogger relay is energized.

Power is supplied

- through terminals 5 and 7 of the rear window defogger relay
- to the rear window defogger.

The rear window defogger has an independent ground.

With power and ground supplied, the rear window defogger filaments heat and defog the rear window.

When the system is activated, the rear window defogger indicator illuminates in the rear window defogger switch.

Power is supplied

- to terminal 3 of the rear window defogger switch (with navigation system), or
- to terminal 30 of the A/C auto amp. (without navigation system)
- from terminal 7 of the rear window defogger relay.

Terminal 4 of the rear window defogger switch (with navigation system) or terminal 32 of the A/C auto amp. (without navigation system), is grounded through body grounds M4, M66 and M147.

REAR WINDOW DEFOGGER

Wiring Diagram — DEF —

Wiring Diagram — DEF —

NBEL0074

EL-DEF-01

GI

MA

EM

LC

EC

FE

AT

TF

PD

AX

SU

BR

ST

RS

BT

HA

SC

EL

IDX

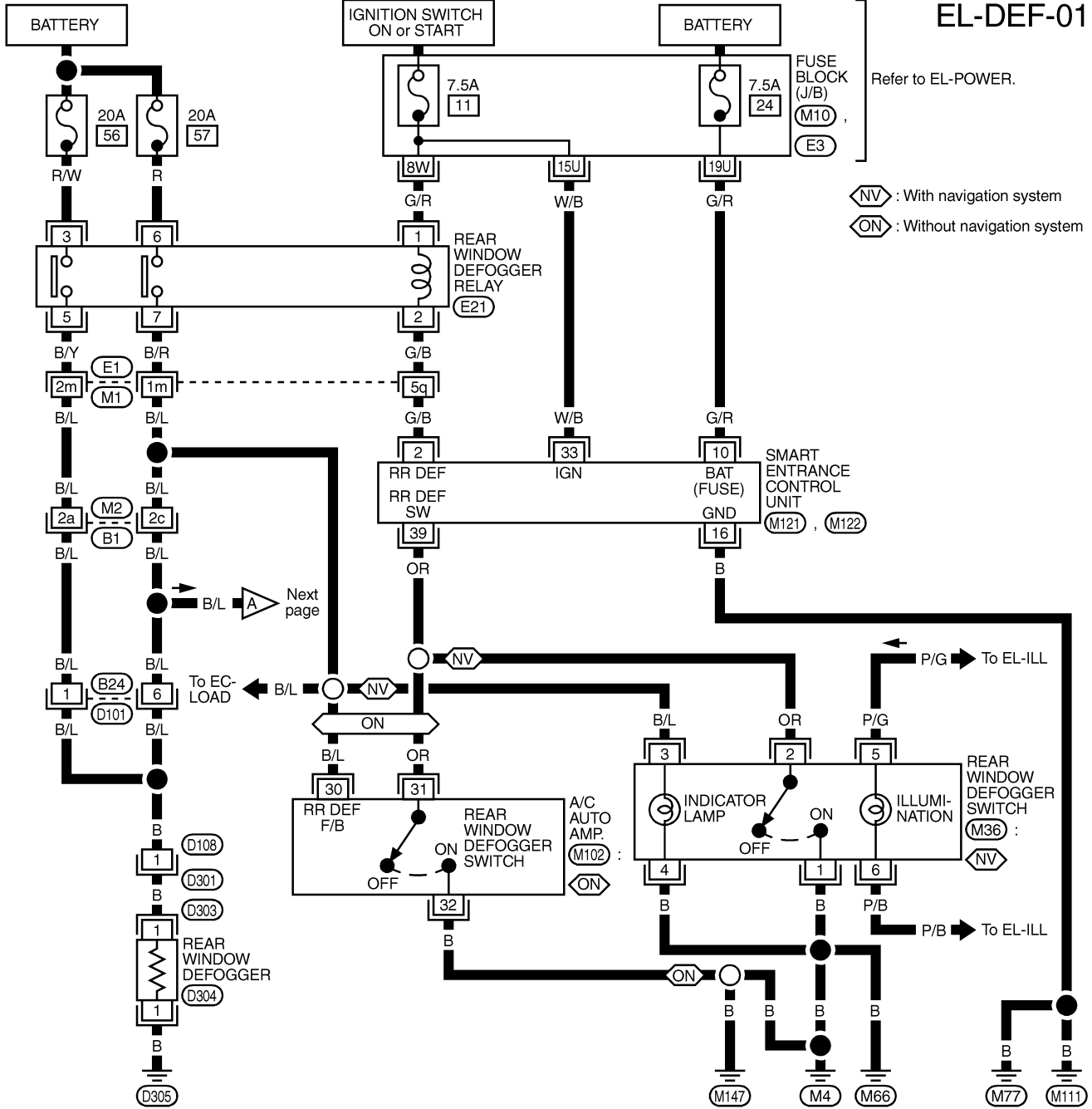

Refer to EL-POWER.

⬢ NV : With navigation system
 ⬢ ON : Without navigation system

Next page

To EC-LOAD

To EL-ILL

To EL-ILL

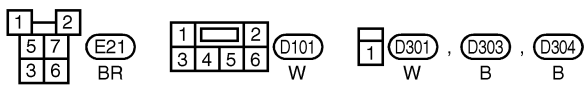
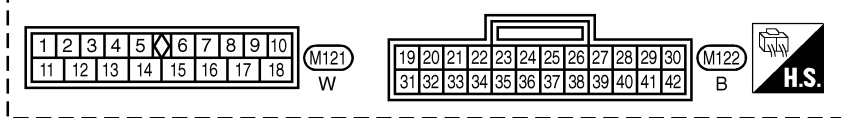
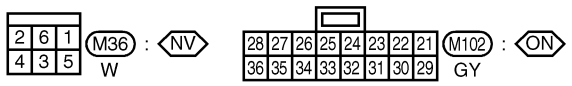

REFER TO THE FOLLOWING.
 (E1), (B1) -SUPER
 MULTIPLE JUNCTION (SMJ)
 (M10), (E3) -FUSE BLOCK-
 JUNCTION BOX (J/B)

REAR WINDOW DEFOGGER

Wiring Diagram — DEF — (Cont'd)

EL-DEF-02

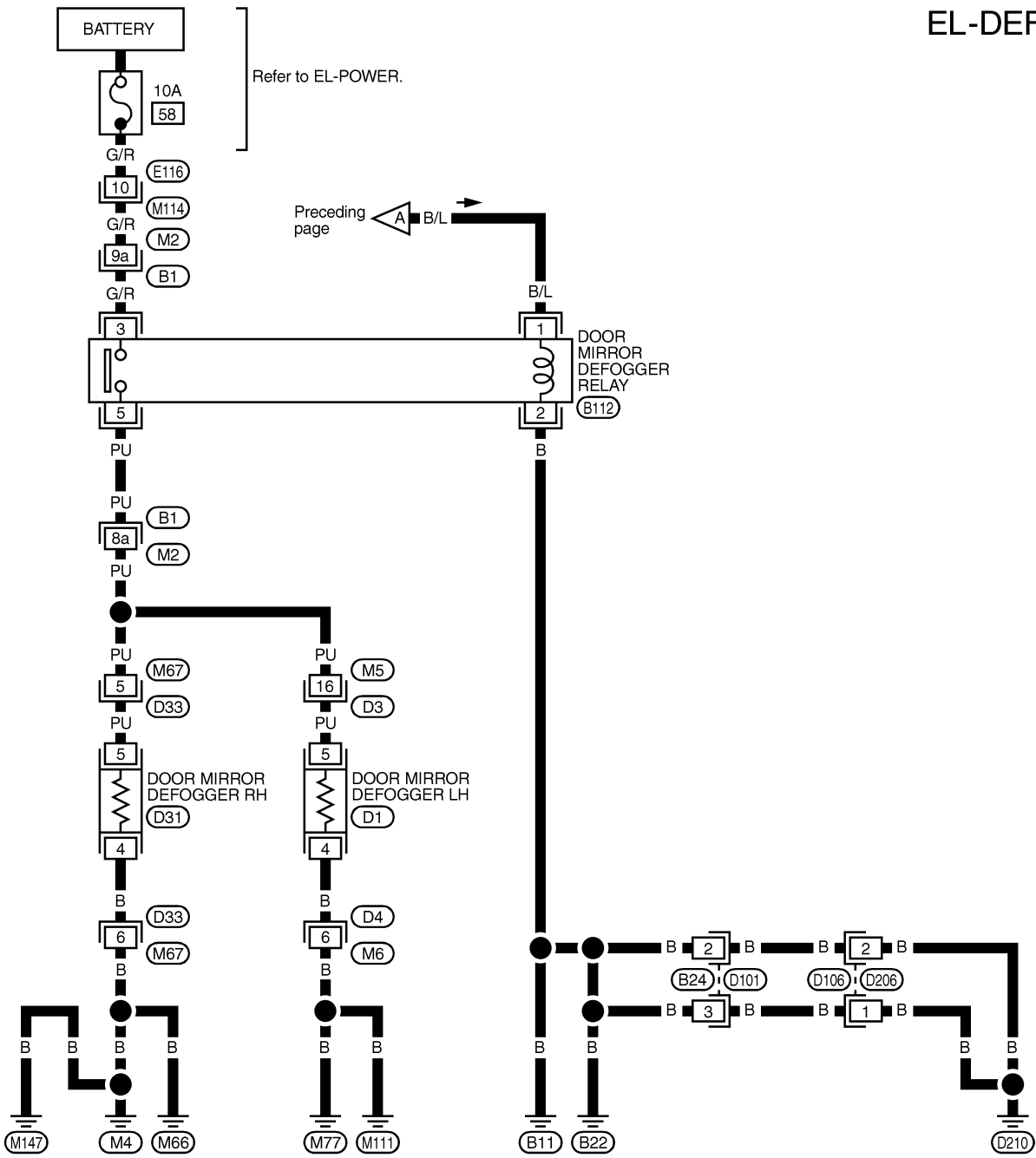

Refer to EL-POWER.

Preceding page A B/L

REFER TO THE FOLLOWING.

(B1) - SUPER MULTIPLE JUNCTION (SMJ)

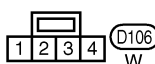
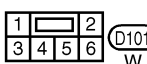
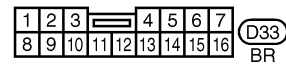
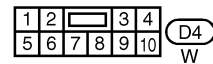
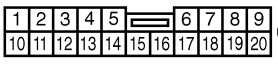
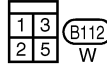
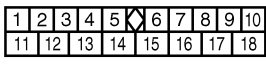

REAR WINDOW DEFOGGER

Trouble Diagnoses

Trouble Diagnoses DIAGNOSTIC PROCEDURE

NBEL0075

NBEL0075S01



SYMPTOM: Rear window defogger does not activate, or does not go off after activating.



1	CHECK REAR WINDOW DEFOGGER OUTPUT SIGNAL
<p>1. Turn ignition switch to ON position. 2. Check voltage between smart entrance control unit harness terminal 2 and ground.</p> <div style="display: flex; justify-content: space-between; align-items: flex-start;"> <div data-bbox="203 441 454 693"> <p>Smart entrance control unit connector (M121)</p> <p>G/B</p> </div> <div data-bbox="519 451 600 651"> <p>H.S. CONNECT</p> </div> <div data-bbox="844 504 1364 672"> <p>Voltage [V]: Rear window defogger switch is "OFF". Approx. 12 Rear window defogger switch is "ON". 0</p> </div> </div> <p style="text-align: right;">SEL384X</p> <p style="text-align: center;">OK or NG</p>	
OK	<p>▶ Check the following.</p> <ul style="list-style-type: none"> ● Rear window defogger relay (Refer to EL-157.) ● Rear window defogger circuit ● Rear window defogger filament (Refer to EL-157.)
NG	<p>▶ GO TO 2.</p>
2	CHECK DEFOGGER RELAY COIL SIDE CIRCUIT
<p>1. Disconnect smart entrance control unit connector. 2. Turn ignition switch to ON position. 3. Check voltage between smart entrance control unit terminal 2 and ground.</p> <div style="display: flex; justify-content: space-between; align-items: flex-start;"> <div data-bbox="267 1249 527 1501"> <p>Smart entrance control unit connector (M121)</p> <p>G/B</p> </div> <div data-bbox="592 1260 673 1459"> <p>H.S. DISCONNECT</p> </div> <div data-bbox="909 1354 1266 1396"> <p>Battery voltage should exist.</p> </div> </div> <p style="text-align: right;">SEL385X</p> <p style="text-align: center;">OK or NG</p>	
OK	<p>▶ GO TO 3.</p>
NG	<p>▶ Check the following.</p> <ul style="list-style-type: none"> ● 7.5A fuse [No. 11, located in the fuse block (J/B)] ● Rear window defogger relay ● Harness for open or short between rear window defogger relay and smart entrance control unit

GI
MA
EM
LC
EC
FE
AT
TF
PD
AX
SU
BR
ST
RS
BT
HA
SC
EL
IDX

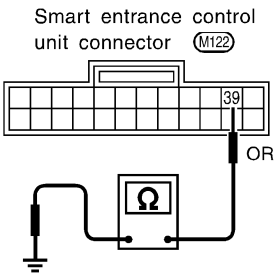
REAR WINDOW DEFOGGER

Trouble Diagnoses (Cont'd)

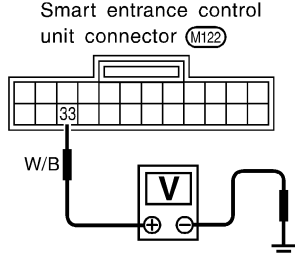
3	CHECK REAR WINDOW DEFOGGER SWITCH INPUT SIGNAL
<p>Check continuity between smart entrance control unit terminal 39 and ground.</p> <div style="display: flex; justify-content: space-between; align-items: flex-start;"> <div style="text-align: center;">  <p>Smart entrance control unit connector (M122)</p> </div> <div style="text-align: center;">  <p>H.S. DISCONNECT</p> </div> <div style="text-align: left;"> <p>Continuity:</p> <p>Rear window defogger switch is pushed. Yes</p> <p>Rear window defogger switch is released. No</p> </div> </div> <p style="text-align: right;">SEL386X</p> <p style="text-align: center;">OK or NG</p>	
OK	▶ GO TO 4.
NG	▶ Check the following. <ul style="list-style-type: none"> ● Rear window defogger switch (with navigation system) (Refer to EL-157.) ● A/C auto amp. (without navigation system) ● Harness for open or short between smart entrance control unit and rear window defogger switch (with navigation system) or A/C auto amp. (without navigation system) ● Rear window defogger switch (with navigation system) or A/C auto amp. (without navigation system) ground circuit

4	CHECK IGNITION INPUT SIGNAL
<p>Check voltage between smart entrance control unit terminal 33 and ground.</p> <div style="display: flex; justify-content: space-between; align-items: flex-start;"> <div style="text-align: center;">  <p>Smart entrance control unit connector (M122)</p> </div> <div style="text-align: center;">  <p>H.S. DISCONNECT</p> </div> <div style="text-align: left;"> <p>Voltage [V]:</p> <p>Ignition switch is "ON". Approx. 12</p> <p>Ignition switch is "OFF". 0</p> </div> </div> <p style="text-align: right;">SEL387X</p> <p style="text-align: center;">OK or NG</p>	
OK	▶ GO TO 5.
NG	▶ Check the following. <ul style="list-style-type: none"> ● 7.5A fuse [No. 11, located in the fuse block (J/B)] ● Harness for open or short between smart entrance control unit and fuse

REAR WINDOW DEFOGGER

Trouble Diagnoses (Cont'd)

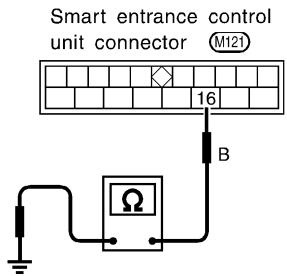
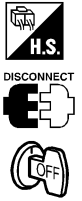
5	CHECK SMART ENTRANCE CONTROL UNIT GROUND CIRCUIT
<p>Check continuity between smart entrance control unit terminal 16 and ground.</p> <div style="display: flex; justify-content: space-around; align-items: center;"> <div style="text-align: center;">  <p>Smart entrance control unit connector (M121)</p> </div> <div style="text-align: center;">  <p>H.S. DISCONNECT</p> </div> <div style="text-align: center;"> <p>Continuity should exist.</p> </div> </div> <p style="text-align: right;">SEL388X</p> <p style="text-align: center;">OK or NG</p>	
OK	▶ Replace smart entrance control unit.
NG	▶ Repair harness or connectors.

GI
MA
EM
LC
EC
FE
AT
TF

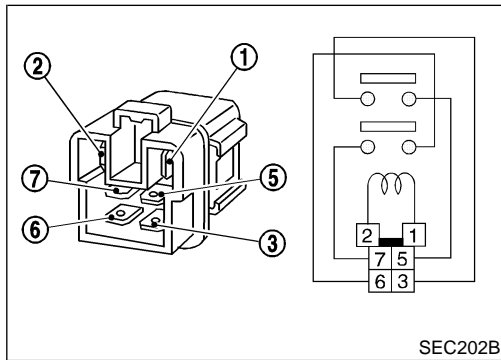

Electrical Components Inspection

REAR WINDOW DEFOGGER RELAY

NBEL0076

Check continuity between terminals 3 and 5, 6 and 7.

NBEL0076S01

Condition	Continuity
12V direct current supply between terminals 1 and 2	Yes
No current supply	No

PD
AX
SU
BR

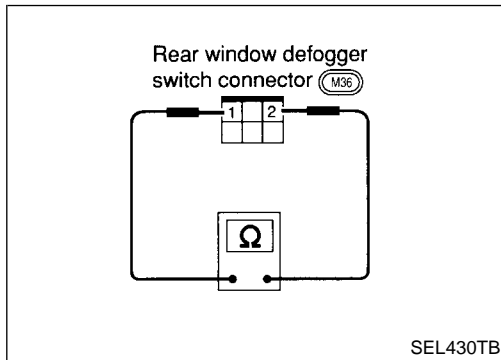

REAR WINDOW DEFOGGER SWITCH

NBEL0076S02

Check continuity between terminals when rear window defogger switch is pushed and released.

Terminals	Condition	Continuity
1 - 2	Rear window defogger switch is pushed	Yes
	Rear window defogger switch is released	No

ST
RS
BT
HA

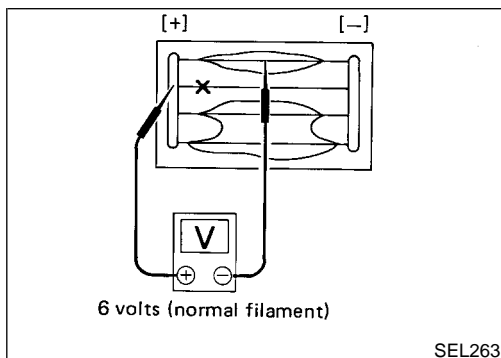

Filament Check

NBEL0077

1. Attach probe circuit tester (in volt range) to middle portion of each filament.

SC
EL
IDX

REAR WINDOW DEFOGGER

Filament Check (Cont'd)

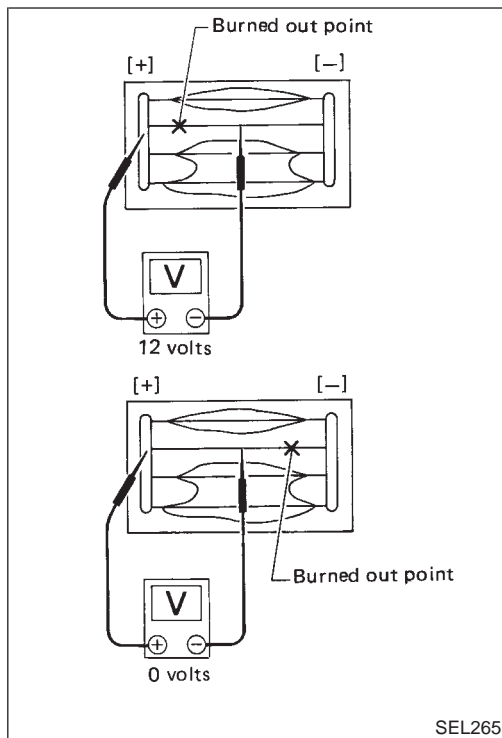

SEL265

2. If a filament is burned out, circuit tester registers 0 or 12 volts.
3. To locate burned out point, move probe to left and right along filament. Test needle will swing abruptly when probe passes the point.

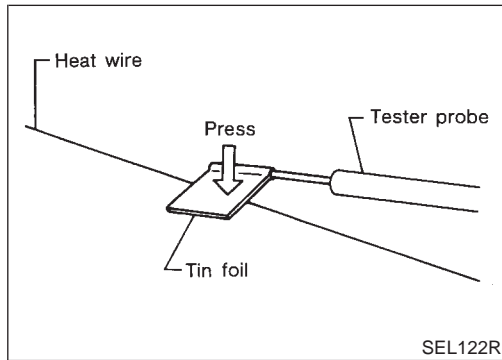

SEL122R

- When measuring voltage, wrap tin foil around the top of the negative probe. Then press the foil against the wire with your finger.

Filament Repair REPAIR EQUIPMENT

NBEL0078

NBEL0078S01

- 1) Conductive silver composition (Dupont No. 4817 or equivalent)
- 2) Ruler 30 cm (11.8 in) long
- 3) Drawing pen
- 4) Heat gun
- 5) Alcohol
- 6) Cloth

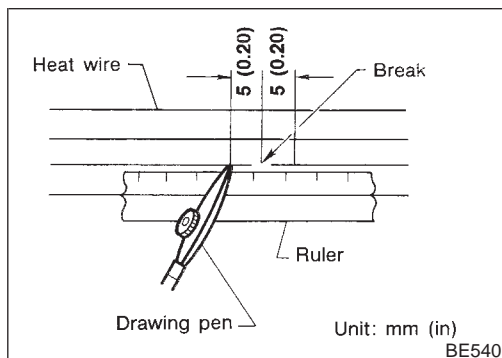

BE540

REPAIRING PROCEDURE

NBEL0078S02

1. Wipe broken heat wire and its surrounding area clean with a cloth dampened in alcohol.
2. Apply a small amount of conductive silver composition to tip of drawing pen.

Shake silver composition container before use.

3. Place ruler on glass along broken line. Deposit conductive silver composition on break with drawing pen. Slightly overlap existing heat wire on both sides [preferably 5 mm (0.20 in)] of the break.

REAR WINDOW DEFOGGER

Filament Repair (Cont'd)

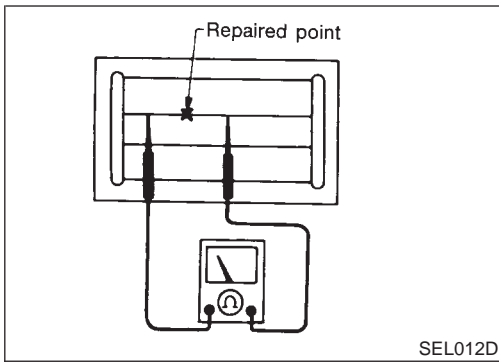

4. After repair has been completed, check repaired wire for continuity. This check should be conducted 10 minutes after silver composition is deposited.

Do not touch repaired area while test is being conducted.

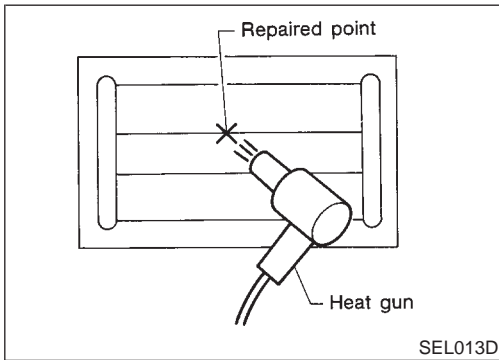

5. Apply a constant stream of hot air directly to the repaired area for approximately 20 minutes with a heat gun. A minimum distance of 3 cm (1.2 in) should be kept between repaired area and hot air outlet. If a heat gun is not available, let the repaired area dry for 24 hours.

GI

MA

EM

LC

EC

FE

AT

TF

PD

AX

SU

BR

ST

RS

BT

HA

SC

EL

IDX

System Description

Refer to Owner's Manual for audio system operating instructions.

Power is supplied at all times

- through 15A fuse [No. 4, located in the fuse block (J/B)]
- to audio unit terminal 6,
- to audio amp. relay terminal 3 and
- to rear speaker amp. terminal 11.

With the ignition switch in the ACC or ON position, power is supplied

- through 10A fuse [No. 10, located in the fuse block (J/B)]
- to audio unit terminal 10.

Ground is supplied through the case of the audio unit.

Ground is supplied

- to audio amp. relay terminal 2
- through body grounds M4, M66 and M147
- to front door speaker LH terminal 5 and
- to front door speaker RH terminal 5
- through body grounds M77 and M111
- to rear speaker amp. terminal 24
- through body grounds B11, B22 and D210.

When the audio unit POWER button is pressed, power is supplied

- to rear speaker amp. terminal 9 and
- to audio amp. relay terminal 1
- from audio unit terminal 12.

Then audio amp. relay is energized and power is supplied

- to front door speaker LH terminal 4 and
- to front door speaker RH terminal 4.

Audio signals are supplied

- through audio unit terminals 1, 2, 3, 4, 13, 14, 15 and 16
- to terminals 2 and 6 of the LH and RH front speakers and terminals 5, 7, 18 and 20 of the rear speaker amp.
- to LH and RH tweeters through terminals 1 and 3 of the front speakers
- to rear LH and RH speakers through terminals 1, 2, 25 and 26 of the rear speaker amp.

Schematic

NBEL0080

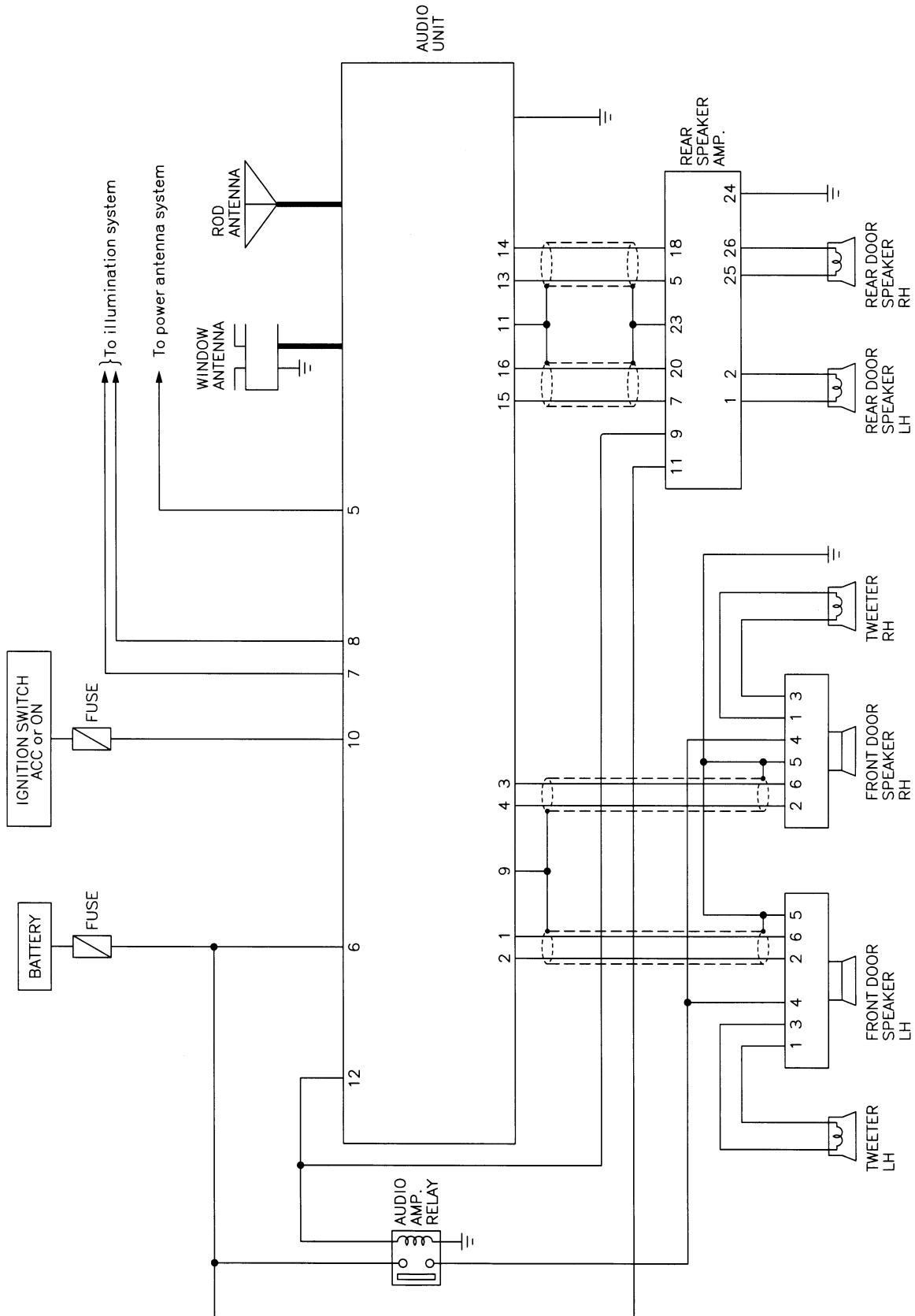

GI

MA

EM

LC

EC

FE

AT

TF

PD

AX

SU

BR

ST

RS

BT

HA

SC

EL

IDX

MEL817L

AUDIO

Wiring Diagram — AUDIO —

Wiring Diagram — AUDIO —

NBEL0081

EL-AUDIO-01

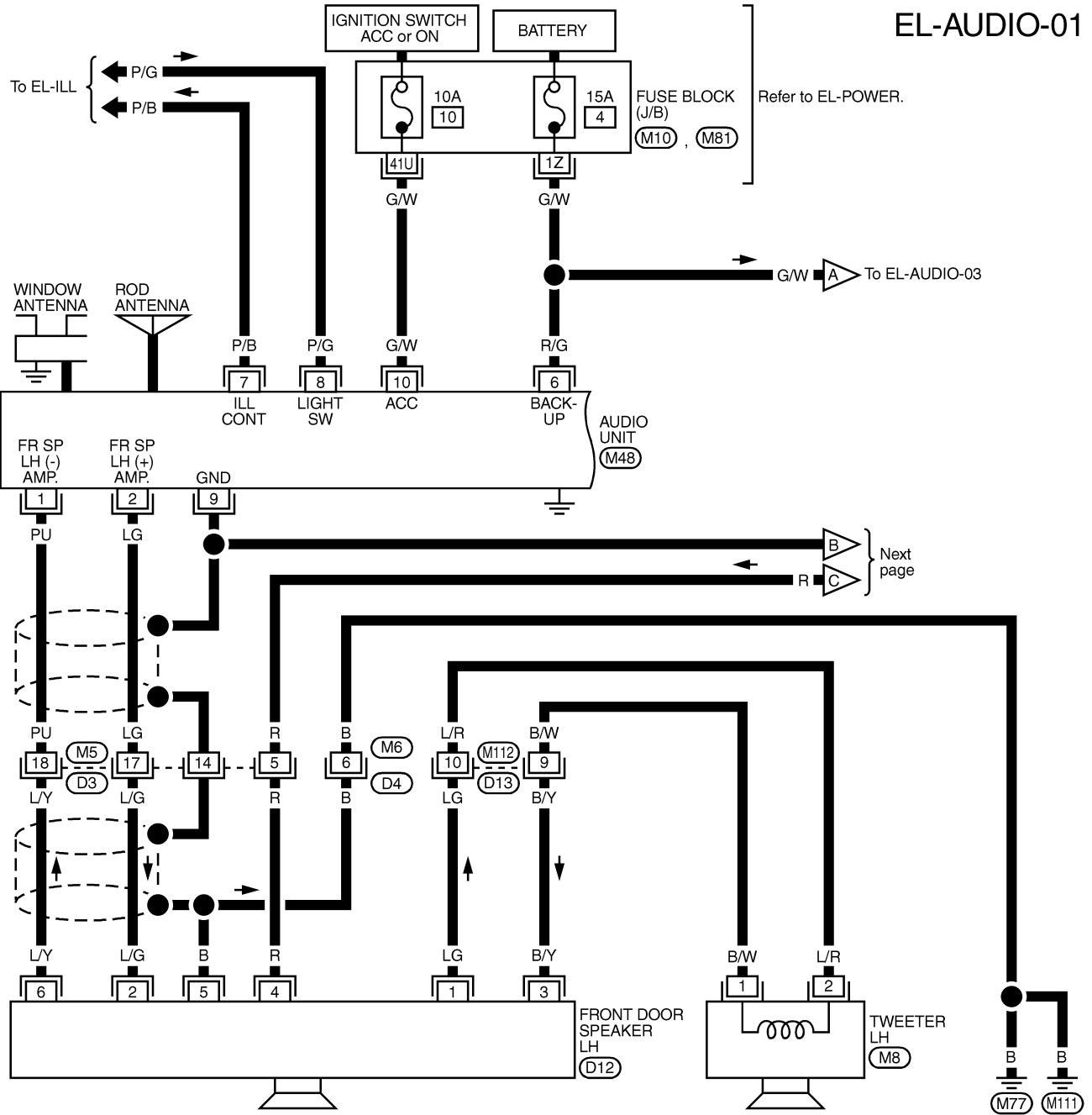

REFER TO THE FOLLOWING.

(M10), (M81) - FUSE BLOCK-
JUNCTION BOX (J/B)

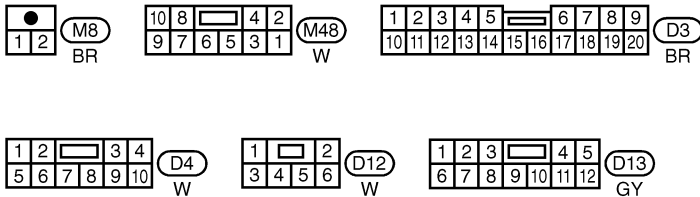

MEL818L

EL-AUDIO-02

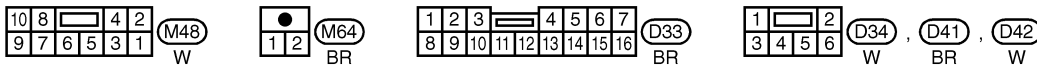
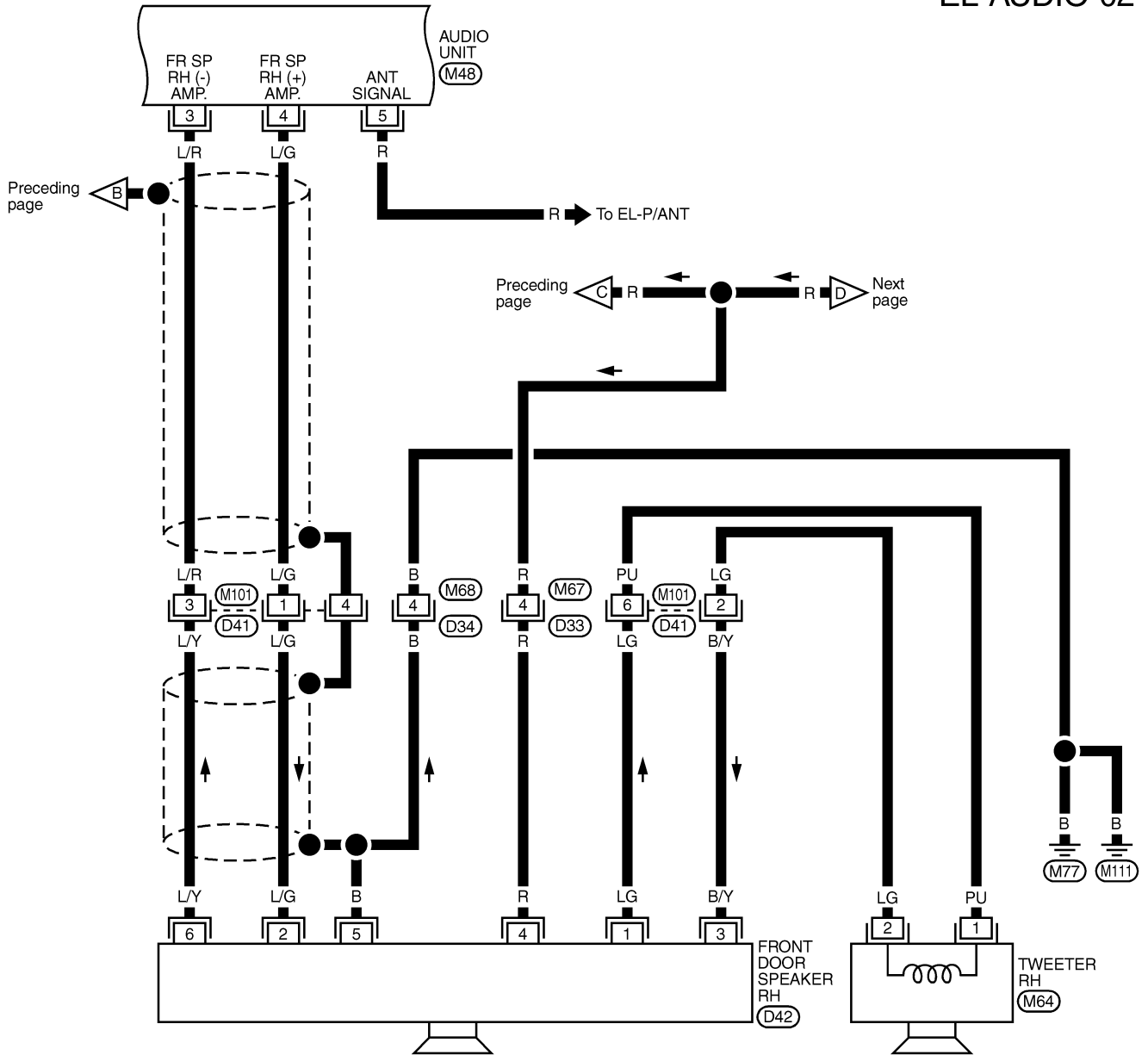

GI
MA
EM
LG
EC
FE
AT
TF
PD
AX
SU
BR
ST
RS
BT
HA
SC
EL
IDX

AUDIO

Wiring Diagram — AUDIO — (Cont'd)

EL-AUDIO-03

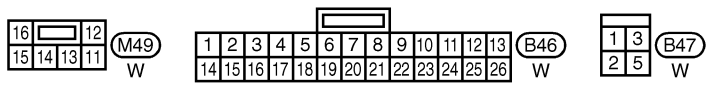
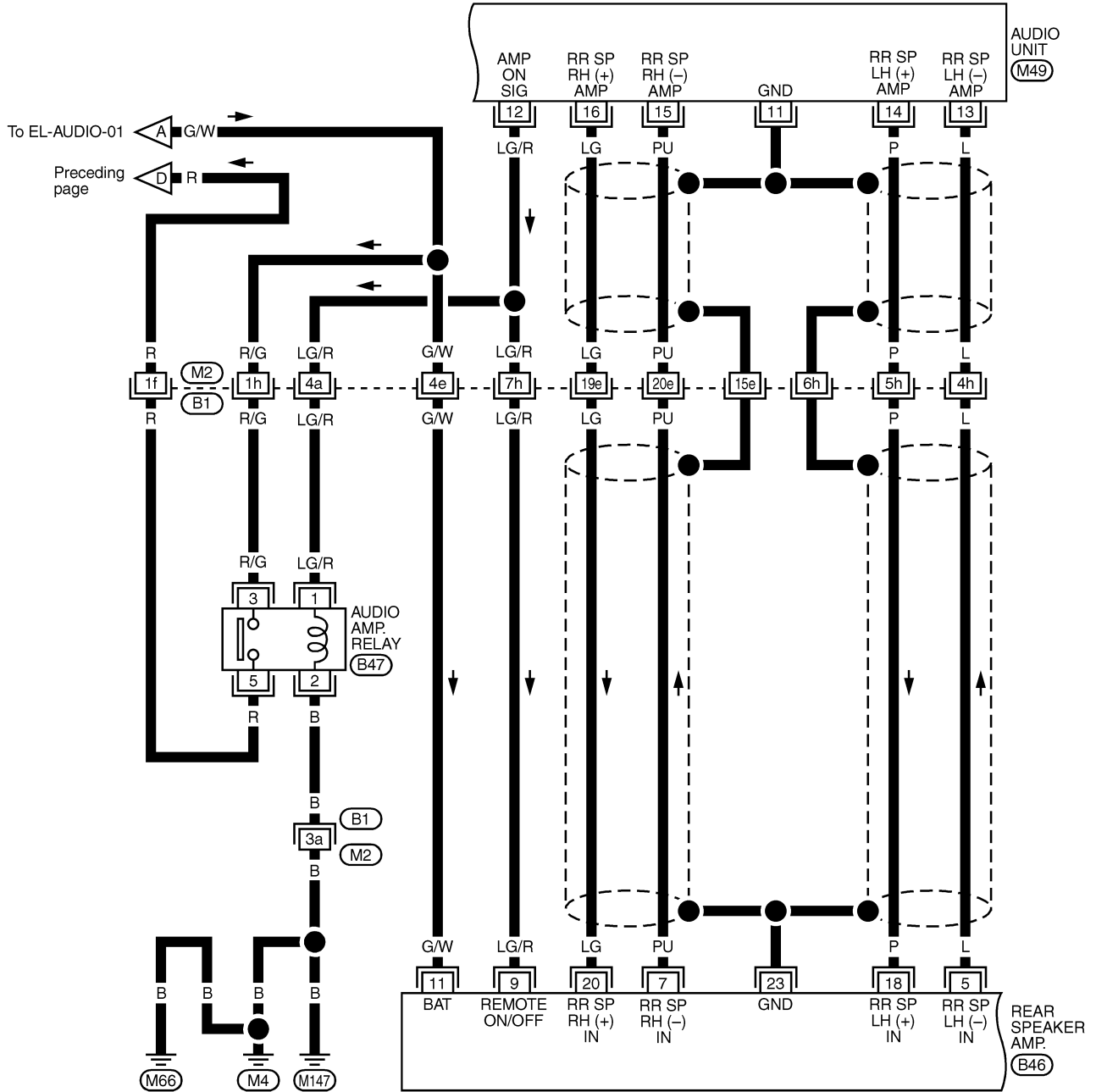

REFER TO THE FOLLOWING.
 (B1) - SUPER MULTIPLE
 JUNCTION (SMJ)

MEL820L

AUDIO

Wiring Diagram — AUDIO — (Cont'd)

EL-AUDIO-04

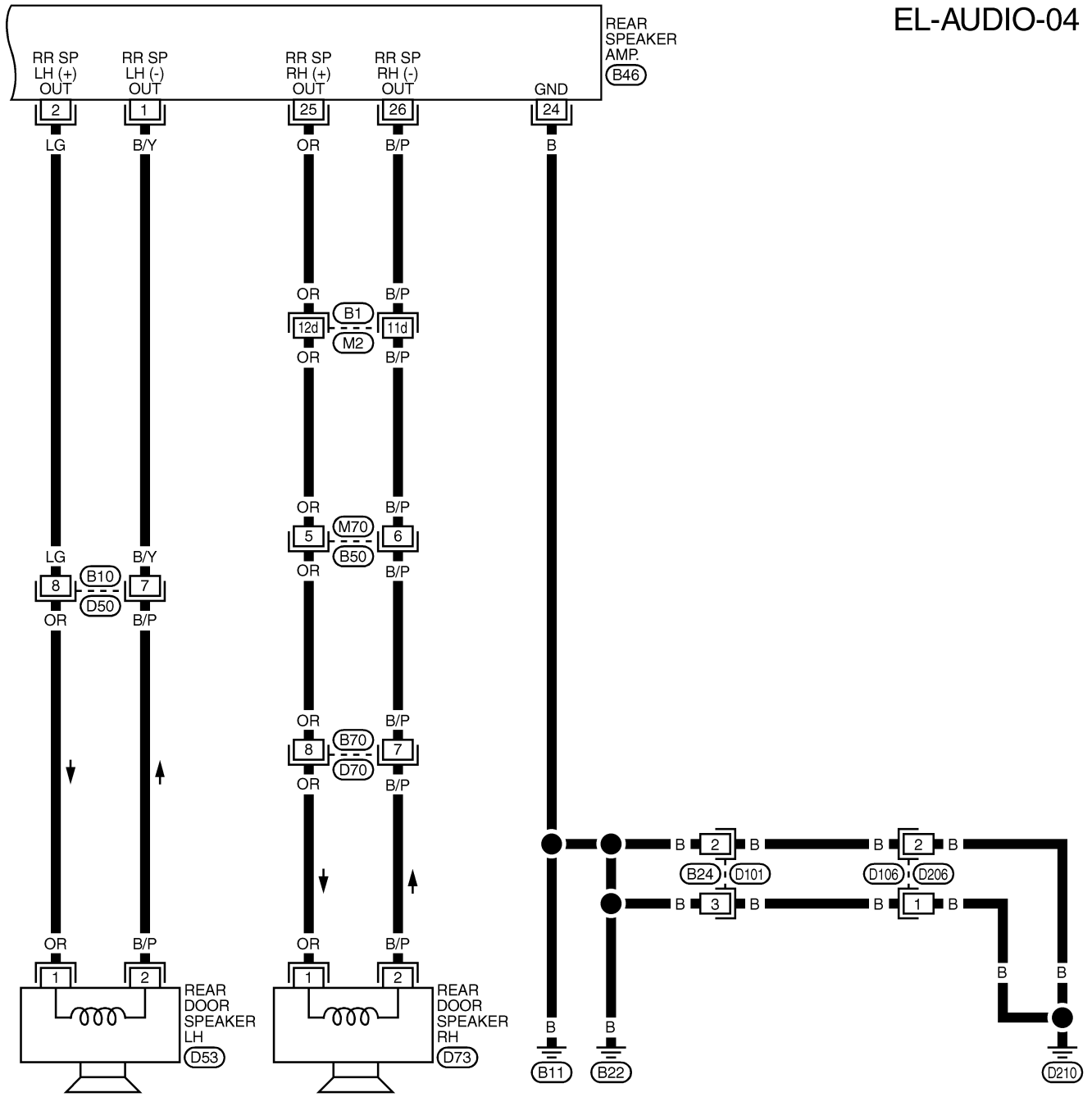

GI
MA
EM
LC
EC
FE
AT
TF
PD
AX
SU
BR
ST
RS
BT
HA
SC
EL
IDX

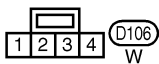
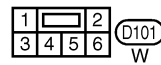
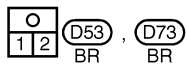
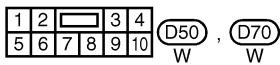
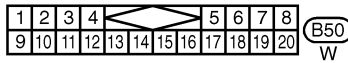
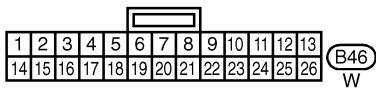

REFER TO THE FOLLOWING.

(B1) - SUPER MULTIPLE JUNCTION (SMJ)

MEL821L

AUDIO

Trouble Diagnoses

Trouble Diagnoses

NBEL0082

NBEL0082S01

AUDIO UNIT

Symptom	Possible causes	Repair order
Audio unit inoperative (no digital display and no sound from speakers).	<ol style="list-style-type: none"> 10A fuse Poor audio unit case ground Audio unit 	<ol style="list-style-type: none"> Check 10A fuse [No. 10, located in fuse block (J/B)]. Turn ignition switch ON and verify that battery positive voltage is present at terminal 10 of audio unit. Check audio unit case ground. Remove audio unit for repair.
Audio unit presets are lost when ignition switch is turned OFF.	<ol style="list-style-type: none"> 15A fuse Audio unit 	<ol style="list-style-type: none"> Check 15A fuse [No. 4, located in fuse block (J/B)] and verify that battery positive voltage is present at terminal 6 of audio unit. Remove audio unit for repair.
AM stations are weak or noisy (FM stations OK).	<ol style="list-style-type: none"> Antenna Poor audio unit ground Audio unit 	<ol style="list-style-type: none"> Check antenna. Check audio unit ground. Remove audio unit for repair.
FM stations are weak or noisy (AM stations OK).	<ol style="list-style-type: none"> Window antenna Audio unit 	<ol style="list-style-type: none"> Check window antenna. Remove audio unit for repair.
Audio unit generates noise in AM and FM modes with engine running.	<ol style="list-style-type: none"> Poor audio unit ground Loose or missing ground bonding straps Ignition condenser or rear window defogger noise suppressor condenser Alternator Ignition coil or secondary wiring Audio unit 	<ol style="list-style-type: none"> Check audio unit ground. Check ground bonding straps. Replace ignition condenser or rear window defogger noise suppressor condenser. Check alternator. Check ignition coil and secondary wiring. Remove audio unit for repair.
Audio unit generates noise in AM and FM modes with accessories on (switch pops and motor noise).	<ol style="list-style-type: none"> Poor audio unit ground Antenna Accessory ground Faulty accessory 	<ol style="list-style-type: none"> Check audio unit ground. Check antenna. Check accessory ground. Replace accessory.
Audio unit controls are operational, but no sound is heard from any speaker.	<ol style="list-style-type: none"> 15A fuse Audio unit output Audio unit 	<ol style="list-style-type: none"> Check 15A fuse [No. 4, located in fuse block (J/B)]. Verify battery positive voltage is present at terminal 3 of audio amp. relay. Check audio unit output voltage (Terminal 12). Remove audio unit for repair.
All front speakers are inoperative.	<ol style="list-style-type: none"> Audio amp. relay Audio amp. relay ground Amp. ON signal 	<ol style="list-style-type: none"> Check audio amp. relay. Check audio amp. relay ground (Terminal 2). Turn ignition switch ACC and audio unit ON. Verify battery positive voltage is present at terminal 1 of audio amp. relay.
Individual front speaker is noisy or inoperative.	<ol style="list-style-type: none"> Speaker ground Power supply Audio unit output Speaker 	<ol style="list-style-type: none"> Check speaker ground (Terminal 5). Check power supply for speaker (Terminal 4). Check audio unit output voltage for speaker. Replace speaker.
Both rear speakers are inoperative.	<ol style="list-style-type: none"> Poor rear speaker amp. ground Power supply Amp. ON signal Rear speaker amp. 	<ol style="list-style-type: none"> Check rear speaker amp. ground circuit. Check power supply for rear speaker amp. (Terminal 11). Turn ignition switch ACC and audio unit ON. Verify battery positive voltage is present at terminal 9 of rear speaker amp. Remove rear speaker amp. for repair.
Individual rear speaker is noisy or inoperative.	<ol style="list-style-type: none"> Speaker Audio unit/amp. output Speaker circuit Audio unit 	<ol style="list-style-type: none"> Check speaker. Check audio unit/amp. output. Check wires for open or short between audio unit/amp. and speakers. Remove audio unit for repair.

Inspection

AUDIO UNIT AND AMP.

NBEL0083

NBEL0083S01

All voltage inspections are made with:

- Ignition switch ON or ACC
- Audio unit ON
- Audio unit and amps. connected (If audio unit or amp. is removed for inspection, supply a ground to the case using a jumper wire.)

GI

MA

EM

ANTENNA

NBEL0083S02

1. Using a jumper wire, clip an auxiliary ground between antenna and body.
 - If reception improves, check antenna ground (at body surface).
 - If reception does not improve, check main feeder cable for short circuit or open circuit.

LC

EC

FE

AT

TF

PD

AX

SU

BR

ST

RS

BT

HA

SC

EL

IDX

AUDIO

Wiring Diagram — REMOTE —

Wiring Diagram — REMOTE —

NBEL0205

EL-REMOTE-01

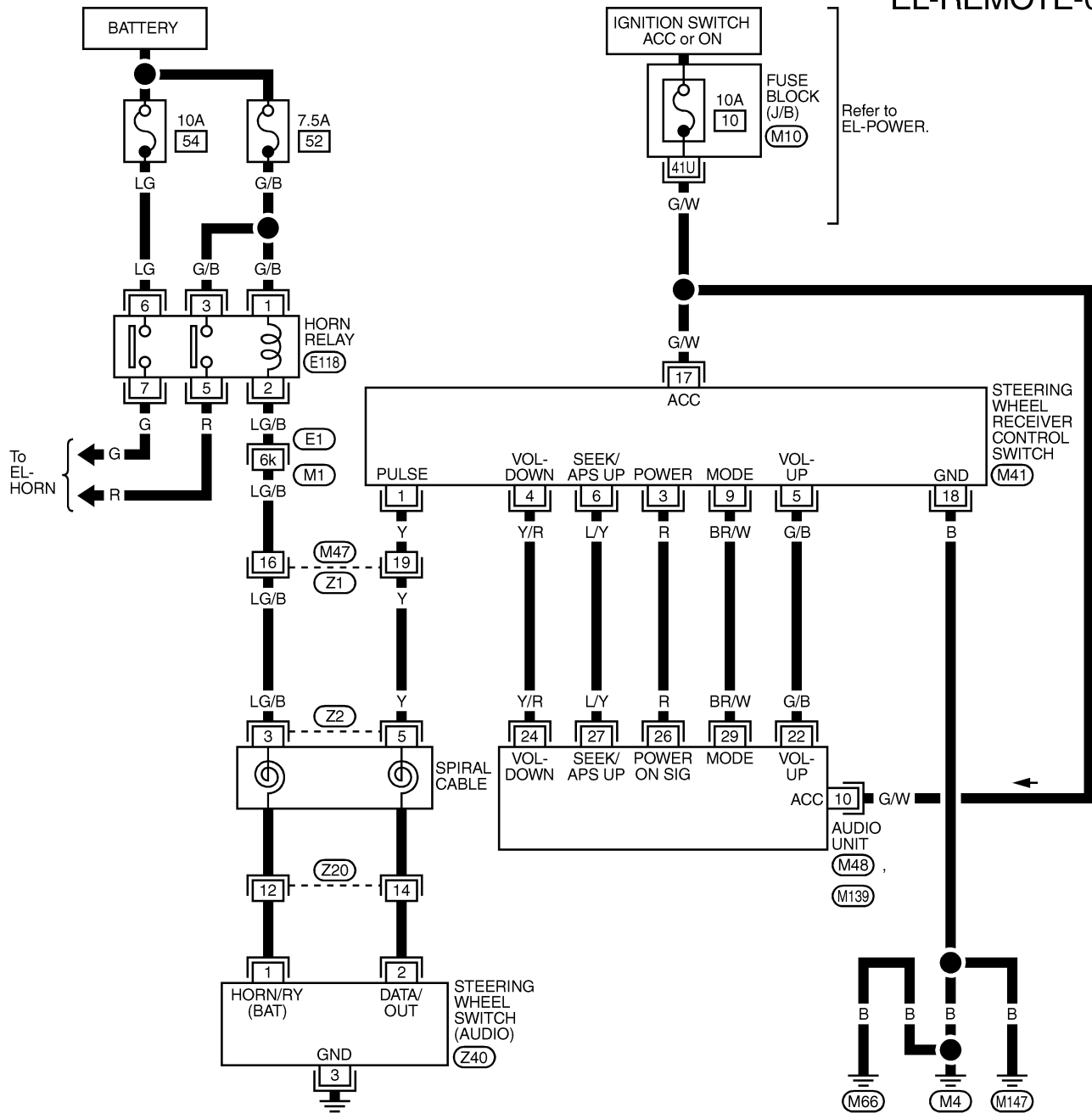

REFER TO THE FOLLOWING.

- (E1) -SUPER
- MULTIPLE JUNCTION (SMJ)
- (M10) -FUSE BLOCK-
JUNCTION BOX (J/B)

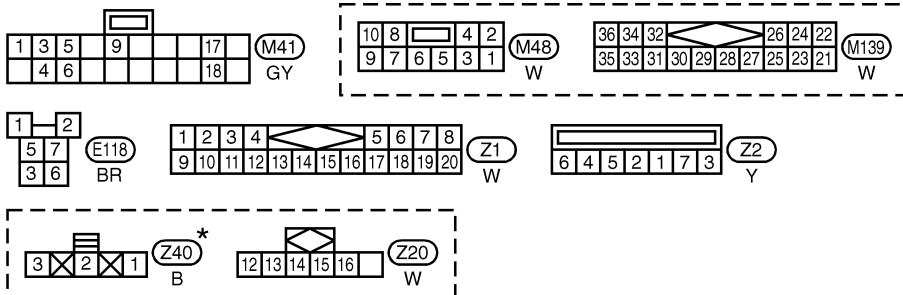

* : This connector is not shown in "HARNESS LAYOUT", EL section.

MEL822L

System Description

NBEL0084

Power is supplied at all times

- through 7.5A fuse [No. 24, located in the fuse block (J/B)]
- to power antenna terminal 6.

Ground is supplied to the power antenna terminal 2 through body grounds M4, M66 and M147.

When the audio unit is turned to the ON position, battery positive voltage is supplied

- through audio unit terminal 5
- to power antenna terminal 4.

The antenna raises and is held in the extended position.

When the audio unit is turned to the OFF position, battery positive voltage is interrupted

- from audio unit terminal 5
- to power antenna terminal 4.

The antenna retracts.

GI

MA

EM

LC

EC

FE

AT

TF

PD

AX

SU

BR

ST

RS

BT

HA

SC

EL

IDX

AUDIO ANTENNA

Wiring Diagram — P/ANT —

Wiring Diagram — P/ANT —

NBEL0085

EL-P/ANT-01

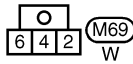
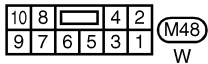
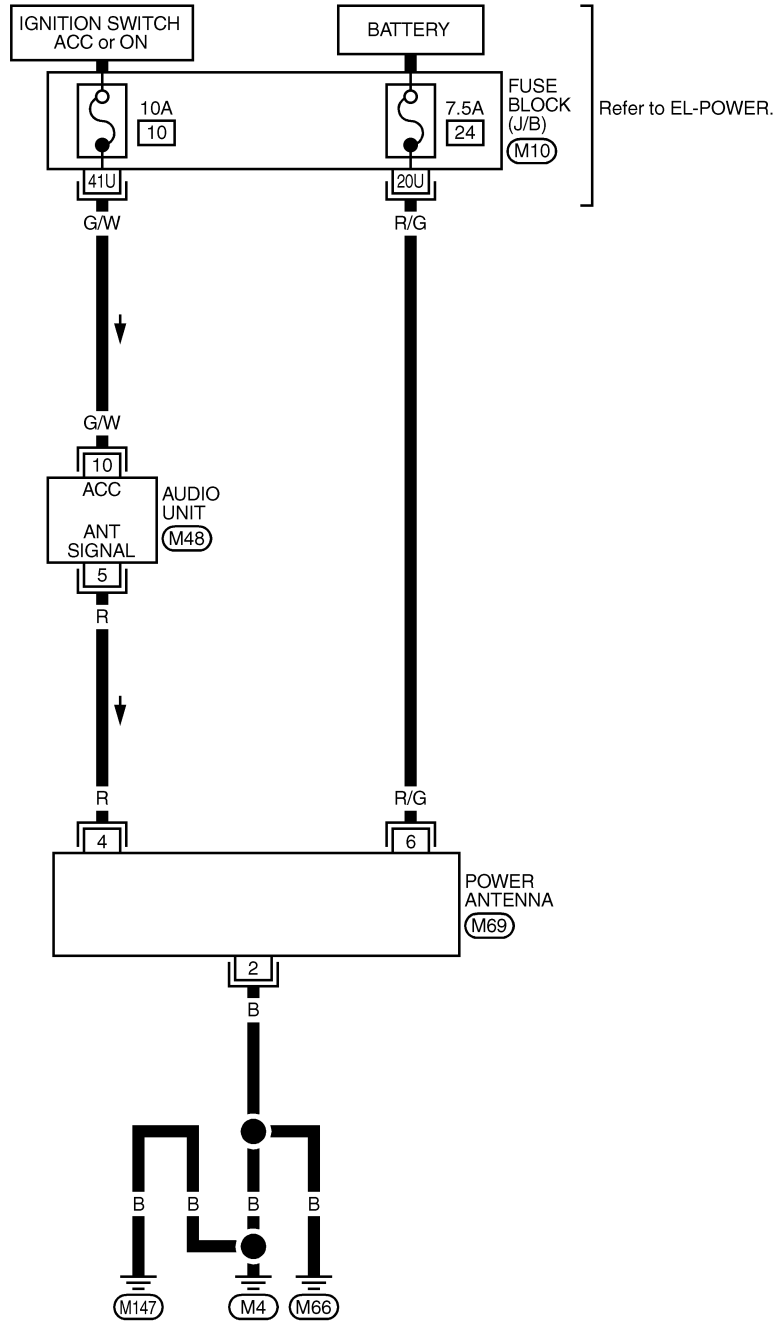

REFER TO THE FOLLOWING.

(M10) - FUSE BLOCK -
JUNCTION BOX (J/B)

MEL824L

Trouble Diagnoses

NBEL0086

NBEL0086S01

POWER ANTENNA

Symptom	Possible causes	Repair order
Power antenna does not operate.	<ol style="list-style-type: none"> 7.5A fuse Audio unit signal Grounds M4, M66 and M147 	<ol style="list-style-type: none"> Check 7.5A fuse [No. 24, located in fuse block (J/B)]. Verify that battery positive voltage is present at terminal 6 of power antenna. Turn ignition switch and audio unit ON. Verify that battery positive voltage is present at terminal 4 of power antenna. Check grounds M4, M66 and M147.

Location of Antenna

NBEL0087

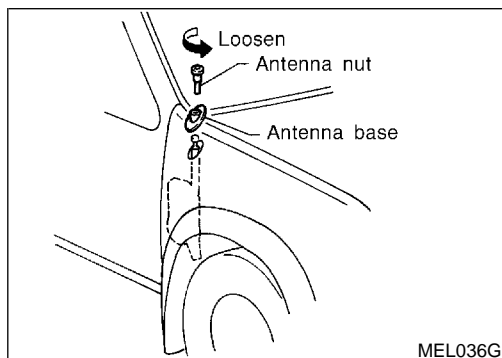
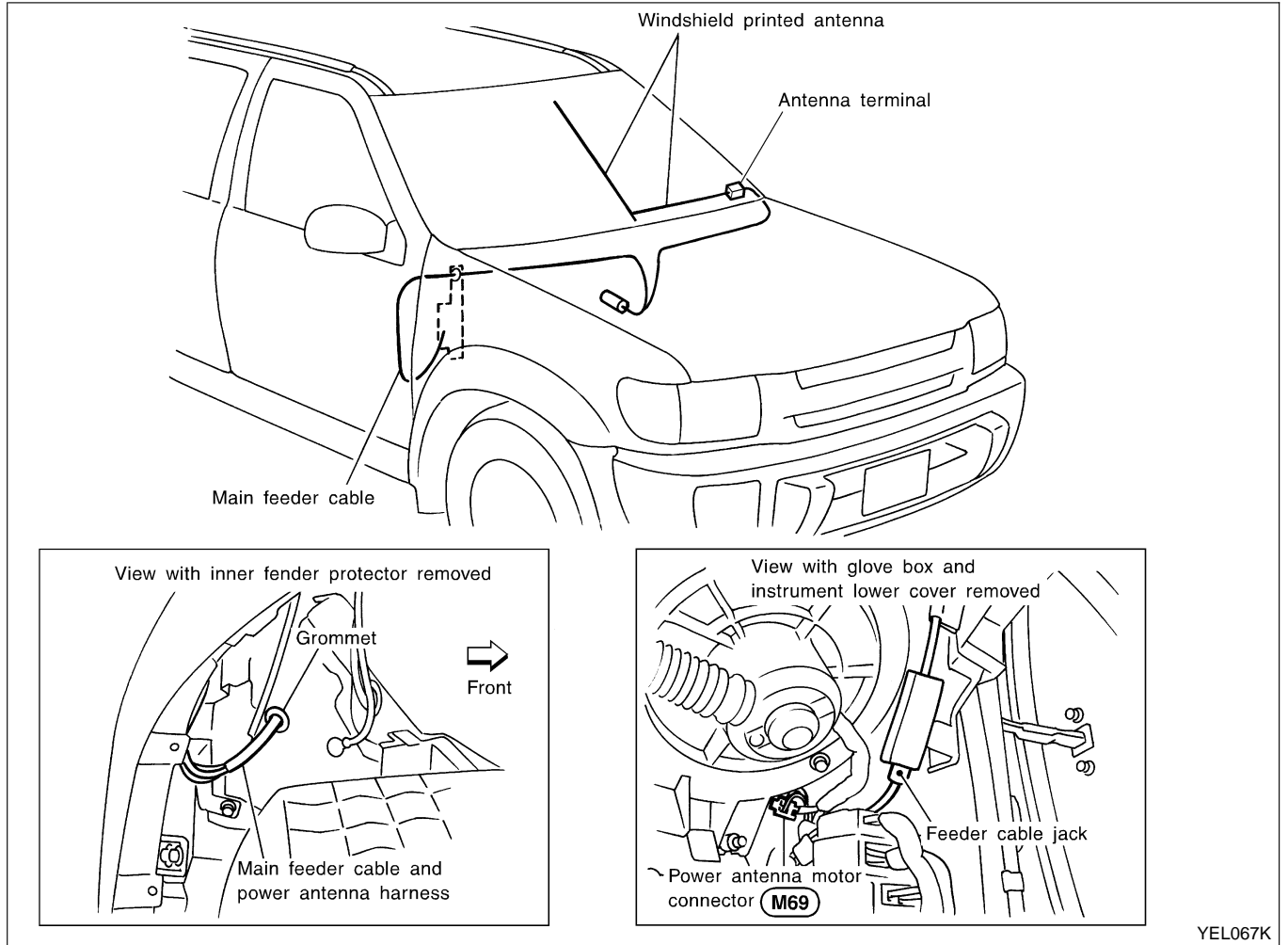

Antenna Rod Replacement REMOVAL

NBEL0088

NBEL0088S01

- Remove antenna nut and antenna base.

GI
MA
EM
LC
EC
FE
AT
TF
PD
AX
SU
BR
ST
RS
BT
HA
SC
EL
IDX

AUDIO ANTENNA

Antenna Rod Replacement (Cont'd)

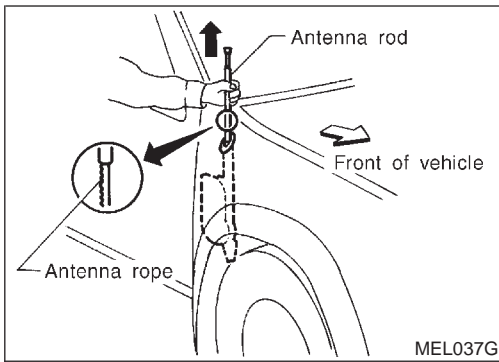

2. Withdraw antenna rod while raising it by operating antenna motor.

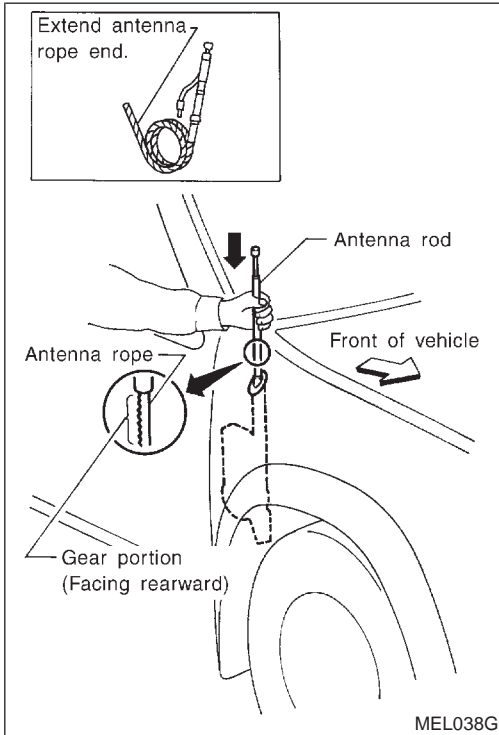

INSTALLATION

NBEL0088S02

1. Lower antenna rod by operating antenna motor.
2. Insert gear section of antenna rope into place with it facing toward antenna motor.
3. As soon as antenna rope is wound on antenna motor, stop antenna motor. Insert antenna rod lower end into antenna motor pipe.
4. Retract antenna rod completely by operating antenna motor.
5. Install antenna nut and base.

System Description

OUTLINE

Electric sunroof system consists of

- Sunroof switch
- Sunroof motor
- Power window relay
- Smart entrance control unit

Smart entrance control unit controls retained power operation.

OPERATION

The sunroof can be opened or closed and tilted up or down with the sunroof switch.

AUTO OPERATION

The power sunroof AUTO feature makes it possible to open and close the sunroof without holding the sunroof switch in the down or up position.

RETAINED POWER OPERATION

When the ignition switch is turned to OFF position from ON or START position, power is supplied for 45 seconds

- to power window relay terminal 2
- from smart entrance control unit terminal 5.

Ground is always supplied

- to power window relay terminal 1
- through body grounds.

When power and ground are supplied, power window relay continues to be energized, and the electrical sunroof can be operated.

The retained power operation is canceled when the driver or passenger side door is opened.

INTERRUPTION DETECTION FUNCTION

The CPU of sunroof motor monitors the sunroof motor operation and the sunroof position (full closed or other) for sunroof by the signals from encoder and limit switch in sunroof motor.

When sunroof motor detects interruption during the following close operation,

- automatic close operation when ignition switch is in the "ON" position
- automatic close operation during retained power operation

sunroof switch controls the motor for open and the sunroof will operate about 150 mm (5.91 in).

NBEL0206

NBEL0206S01

GI

MA

EM

NBEL0206S02

LC

NBEL0206S03

EC

NBEL0206S04

FE

AT

TF

PD

AX

NBEL0206S05

SU

BR

ST

RS

BT

HA

SC

EL

IDX

POWER SUNROOF

Wiring Diagram — SROOF —

Wiring Diagram — SROOF —

NBEL0089

EL-SROOF-01

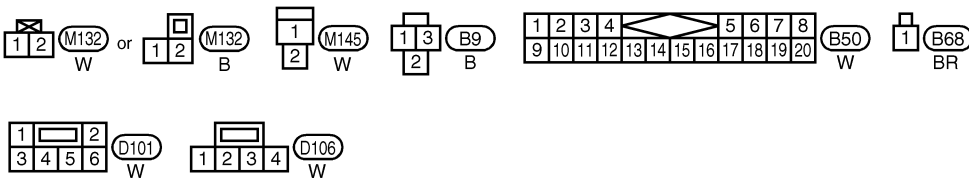
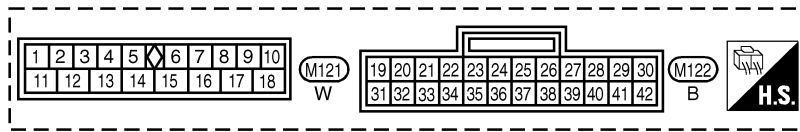
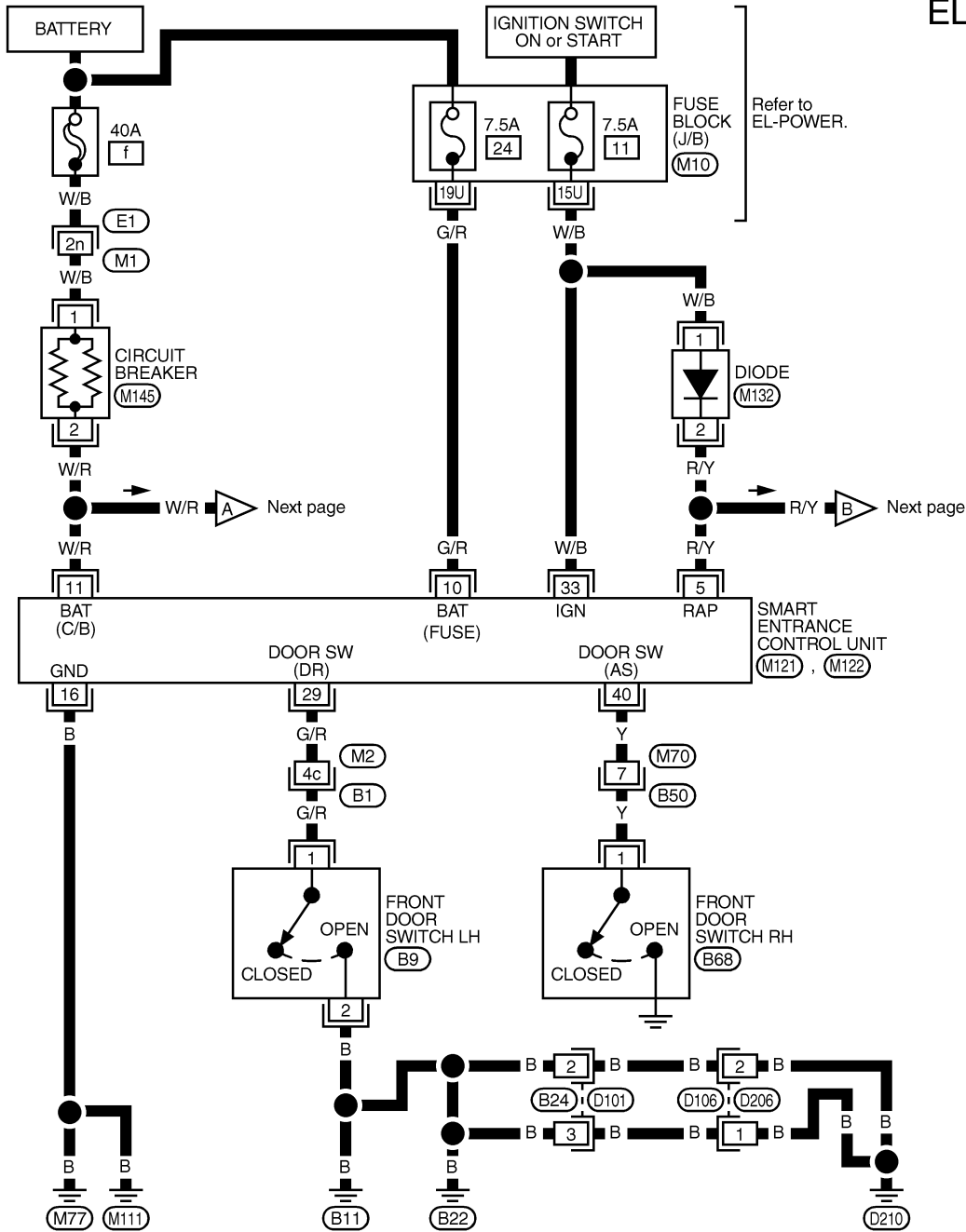

REFER TO THE FOLLOWING.

- (E1) , (B1) - SUPER MULTIPLE JUNCTION (SMJ)
- (M10) - FUSE BLOCK - JUNCTION BOX (J/B)

MEL0070

POWER SUNROOF

Wiring Diagram — SROOF — (Cont'd)

EL-SROOF-02

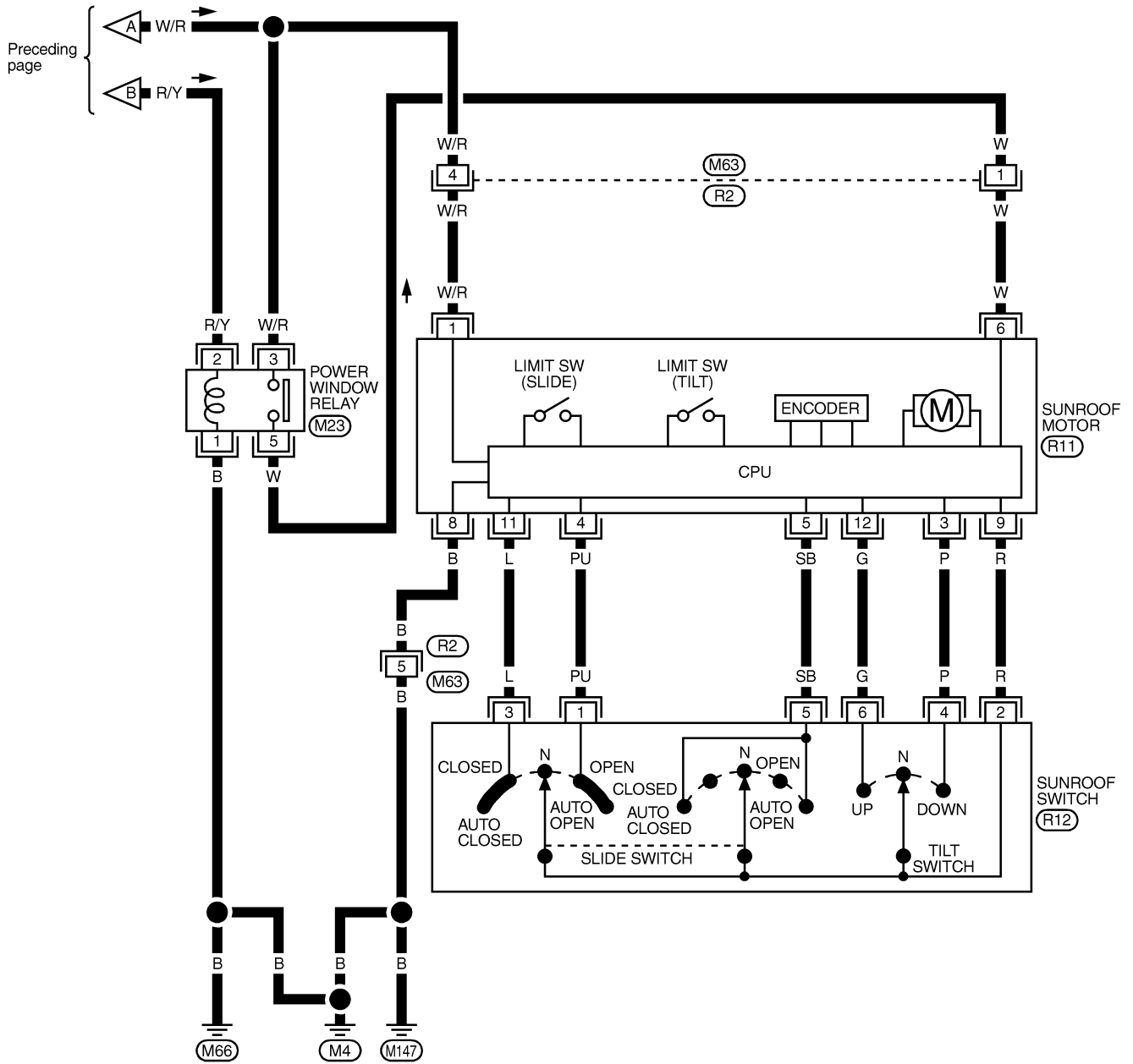

GI
MA
EM
LC
EC
FE
AT
TF
PD
AX
SU
BR
ST
RS
BT
HA
SC
EL
IDX

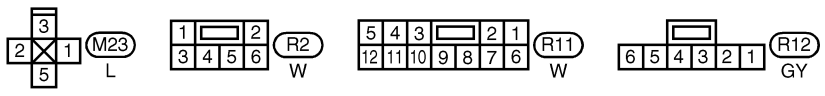

MEL826L

POWER SUNROOF

Trouble Diagnoses

Trouble Diagnoses

NBEL0207

Symptom	Possible cause	Repair order
Power sunroof cannot be operated using any switch.	<ol style="list-style-type: none"> 7.5A fuse, 40A fusible link and M145 circuit breaker Power window relay ground circuit Sunroof motor ground circuit Power window relay Sunroof motor circuit Sunroof switch Sunroof switch circuit Sunroof motor 	<ol style="list-style-type: none"> Check 7.5A fuse [No. 11, located in fuse block (J/B)], 40A fusible link (letter f, located in fuse and fusible link box) and M145 circuit breaker. Turn ignition switch "ON" and verify battery positive voltage is present at terminals 2 and 3 of power window relay and terminal 1 of sunroof motor. Check power window relay ground circuit. Check sunroof motor ground circuit. Check power window relay. Check the wire between power window relay and sunroof motor. Check sunroof switch. Check harness between sunroof switch and sunroof motor. Check sunroof motor.
Power sunroof cannot be operated using one of the sunroof switches.	<ol style="list-style-type: none"> Sunroof switch Sunroof switch circuit 	<ol style="list-style-type: none"> Check sunroof switch. Check the harness between sunroof motor and sunroof switch.
Power sunroof auto function cannot be operated properly.	<ol style="list-style-type: none"> Sunroof slide mechanism Sunroof switch Sunroof switch circuit Sunroof motor 	<ol style="list-style-type: none"> Check the following. <ol style="list-style-type: none"> Check obstacles in sunroof, etc. Check worn or deformed sunroof. Check sunroof sash tilted too far inward or outward. Check sunroof switch. Check harness between sunroof motor and sunroof switch. Replace sunroof motor.
Retained power operation does not operate properly.	<ol style="list-style-type: none"> RAP signal circuit Driver or passenger side door switch circuit Smart entrance control unit 	<ol style="list-style-type: none"> Check harness between power window relay terminal 2 and smart entrance control unit terminal 5. Check the following. <ol style="list-style-type: none"> Harness between smart entrance control unit and driver or passenger side door switch for short circuit Driver or passenger side door switch ground circuit Driver or passenger side door switch Check smart entrance control unit. (EL-324)

DOOR MIRROR

Wiring Diagram — MIRROR —

Wiring Diagram — MIRROR —

NBEL0090

EL-MIRROR-01

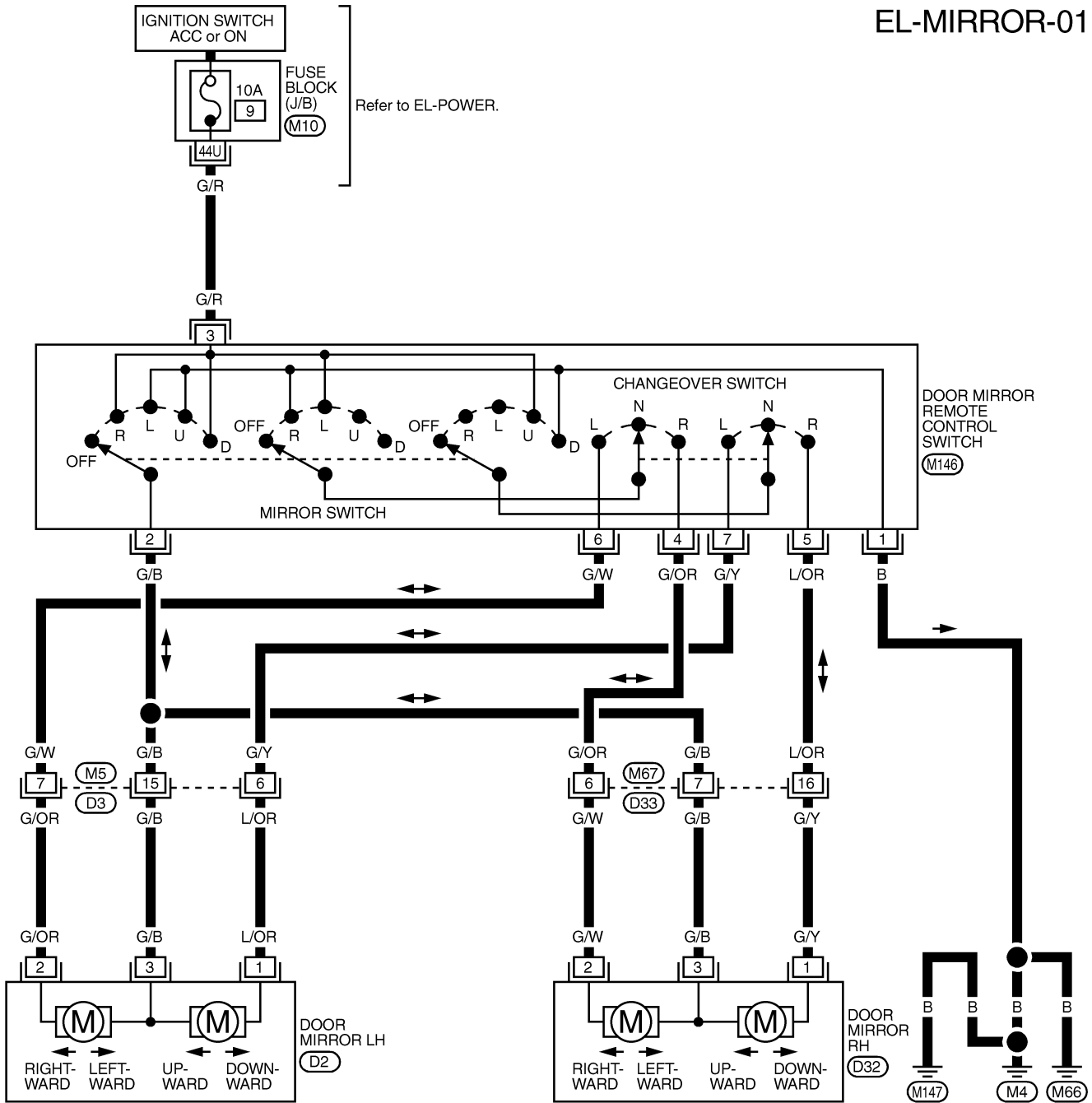

GI
MA
EM
LC
EC
FE
AT
TF
PD
AX
SU
BR
ST
RS
BT
HA
SC
EL
IDX

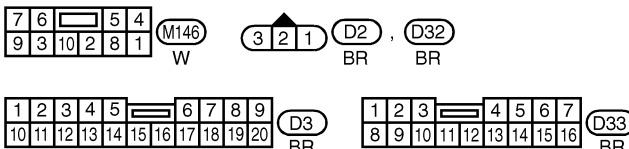

REFER TO THE FOLLOWING.
M10 - FUSE BLOCK -
JUNCTION BOX (J/B)

MEL827L

GLASS HATCH OPENER

System Description

System Description

NBEL0208

NBEL0208S01

OUTLINE

Glass hatch opener system consists of

- Glass hatch opener actuator
- Glass hatch opener switch
- Rear wiper motor (Link switch)

OPERATION

NBEL0208S02

Power is always supplied

- to glass hatch opener actuator terminal 2
- through 10A fuse [No. 5, located in the fuse block (J/B)].

When rear wiper motor is not operated (link switch ON) and glass hatch opener switch is turned ON, ground is supplied

- to glass hatch actuator terminal 1
- through rear wiper motor terminals 1 and 5
- through glass hatch opener switch terminals 2 and 1
- through body grounds M77 and M111.

Power and ground are supplied glass hatch is opened.

GLASS HATCH OPENER

Wiring Diagram — TLID —

Wiring Diagram — TLID —

NBEL0091

EL-TLID-01

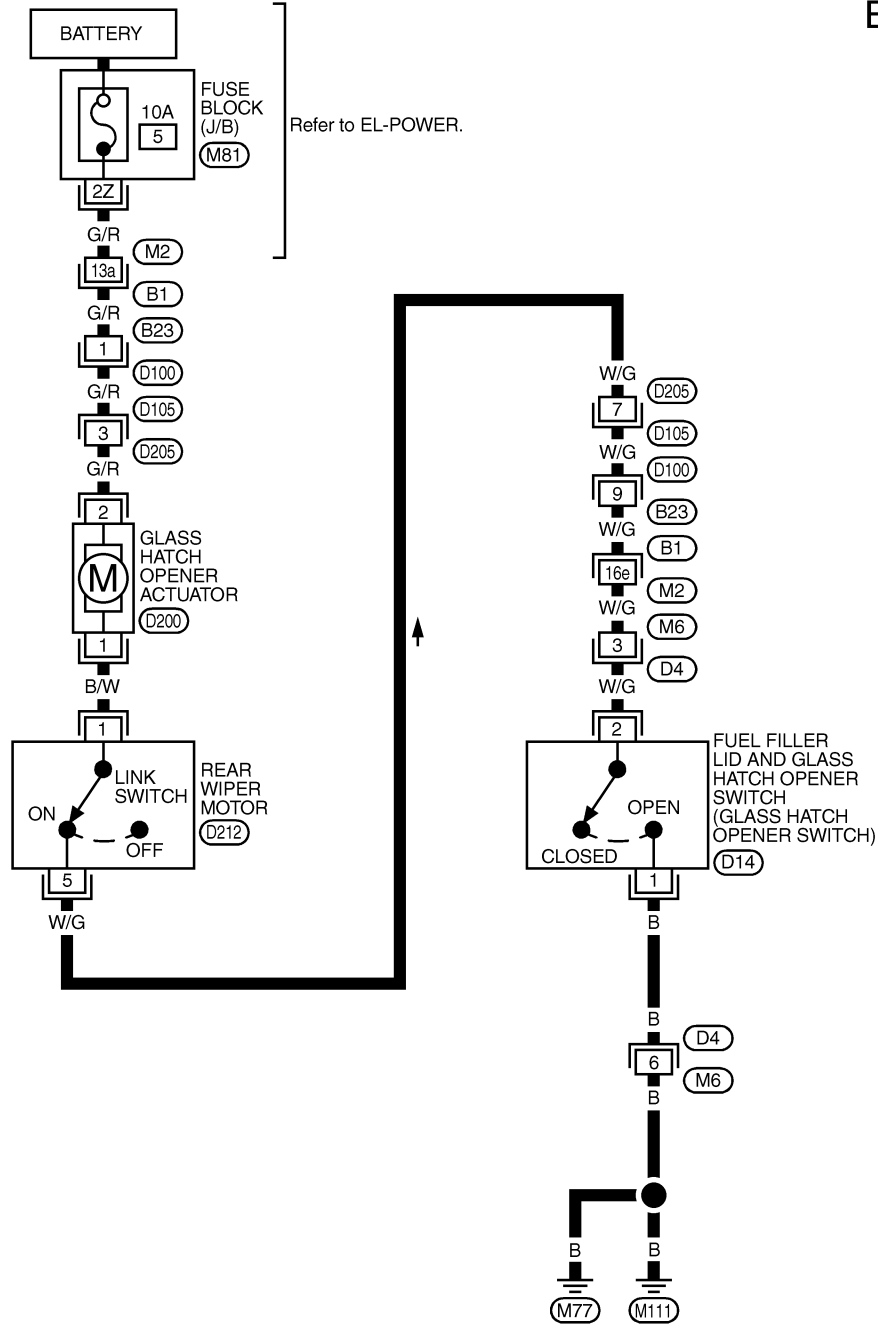

Refer to EL-POWER.

GI
MA
EM
LC
EC
FE
AT
TF
PD
AX
SU
BR
ST
RS
BT

HA
SC
EL
IDX

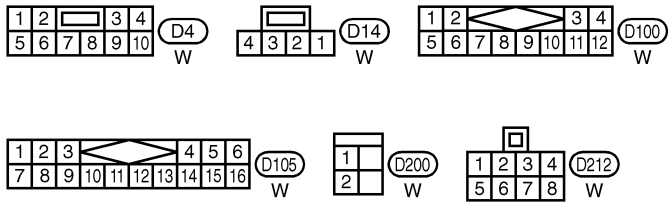

REFER TO THE FOLLOWING.

- (B1) -SUPER
- MULTIPLE JUNCTION (SMJ)
- (M81) -FUSE BLOCK-
- JUNCTION BOX (J/B)

FUEL FILLER LID OPENER

Wiring Diagram — F/LID —

Wiring Diagram — F/LID —

NBEL0168

EL-F/LID-01

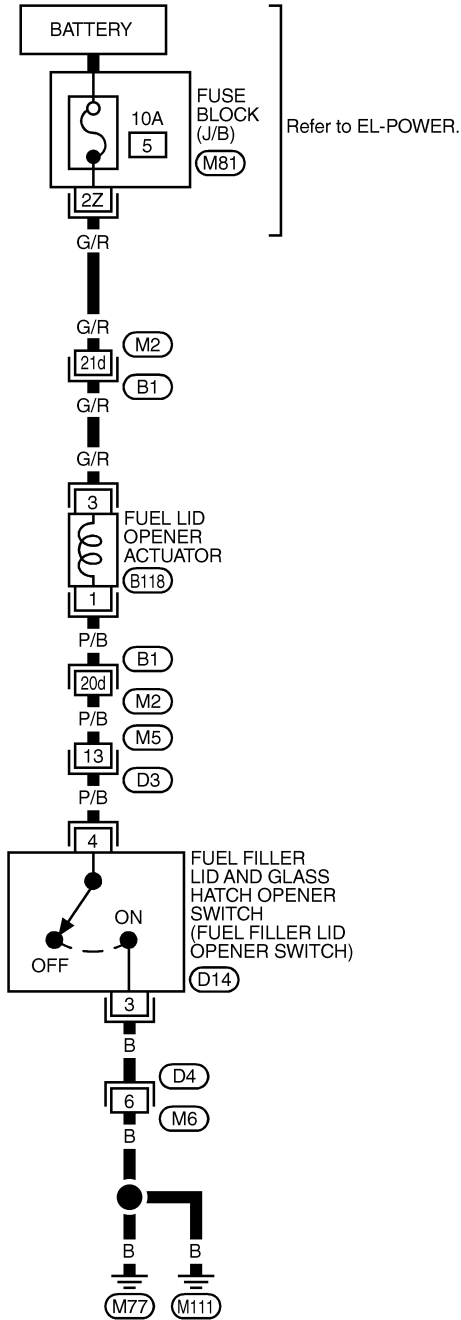

Refer to EL-POWER.

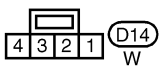
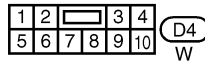
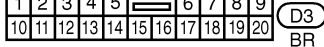
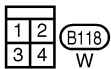

REFER TO THE FOLLOWING.

(B1) - SUPER MULTIPLE

JUNCTION (SMJ)

(M81) - FUSE BLOCK -

JUNCTION BOX (J/B)

MEL829L

POWER SEAT

Wiring Diagram — SEAT —

Wiring Diagram — SEAT —

NBEL0092

EL-SEAT-01

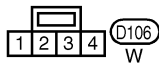
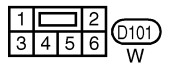
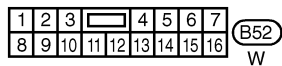
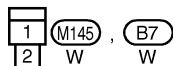
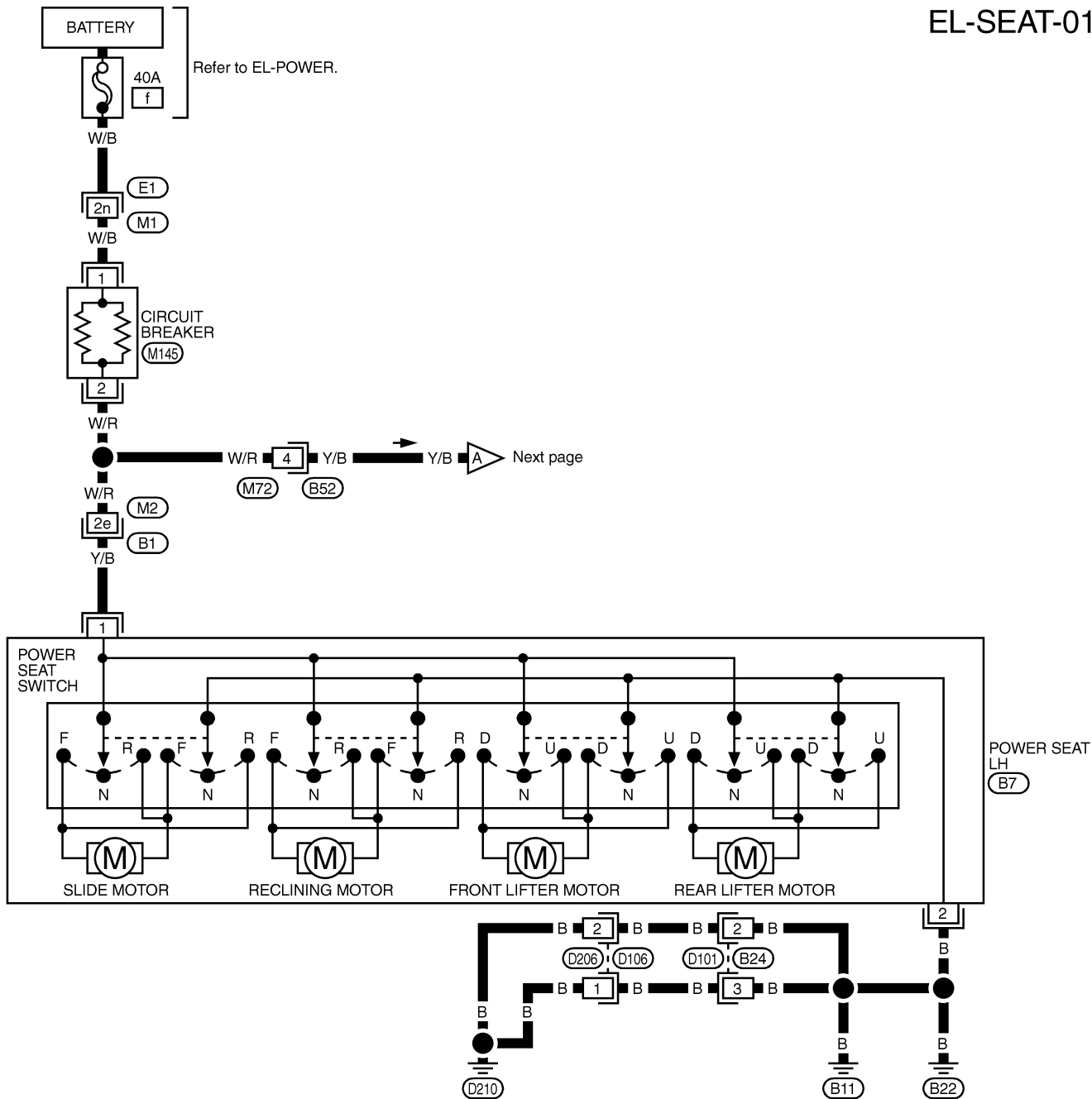

REFER TO THE FOLLOWING.
 (E1), (B1) - SUPER
 MULTIPLE JUNCTION (SMJ)

- GI
- MA
- EM
- LC
- EC
- FE
- AT
- TF
- PD
- AX
- SU
- BR
- ST
- RS
- BT
- HA
- SC
- EL
- IDX

MEL830L

POWER SEAT

Wiring Diagram — SEAT — (Cont'd)

EL-SEAT-02

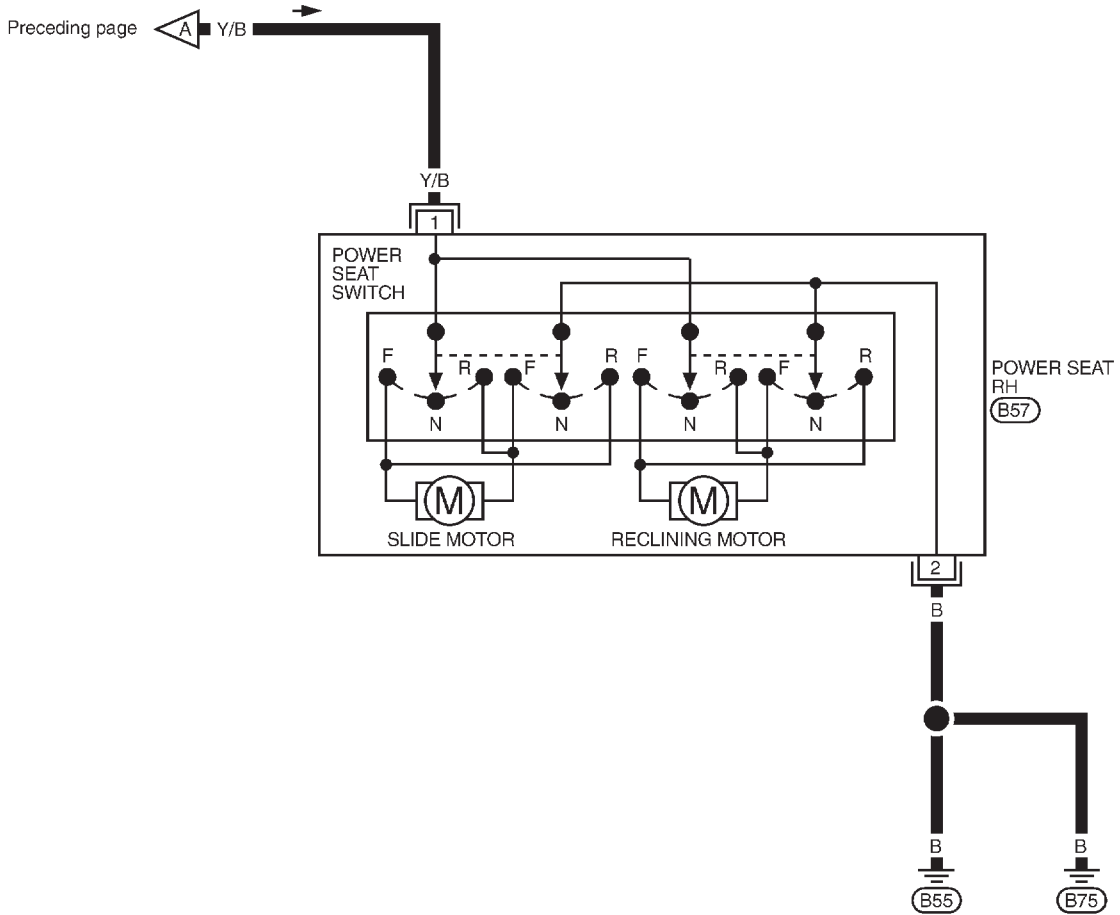

MEL601F

HEATED SEAT

Wiring Diagram — HSEAT —

Wiring Diagram — HSEAT —

NBEL0093

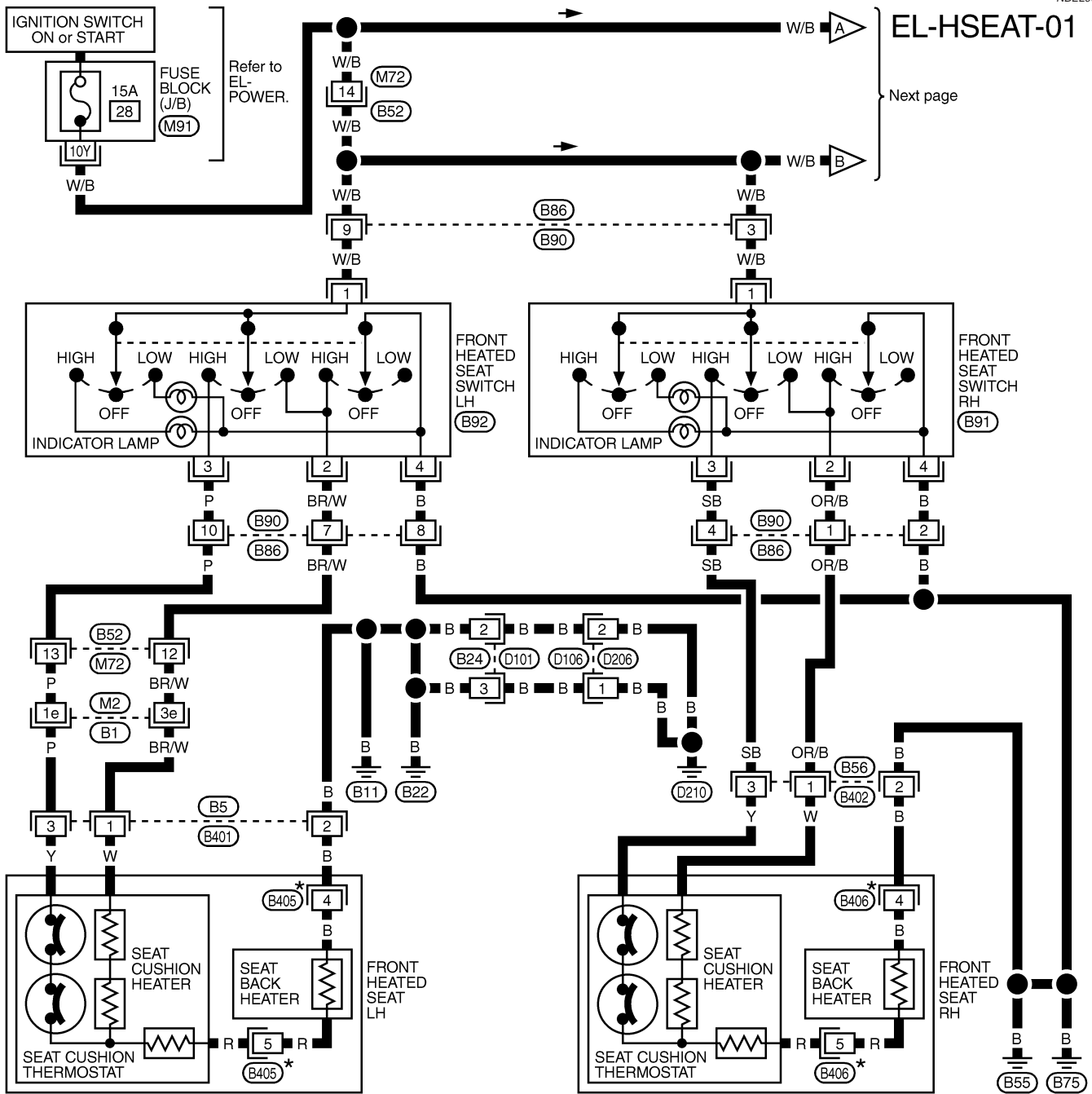

REFER TO THE FOLLOWING.

- (B1) -SUPER
- MULTIPLE JUNCTION (SMJ)
- (M91) -FUSE BLOCK- JUNCTION BOX (J/B)

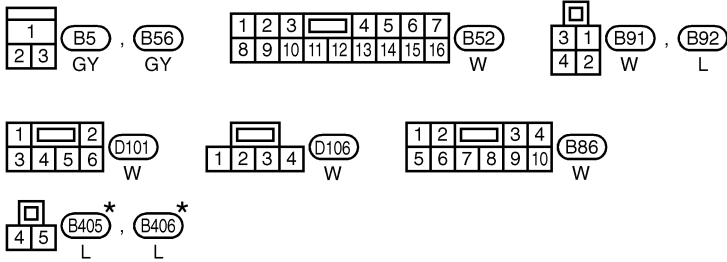

* : This connector is not shown in "HARNESS LAYOUT", EL section.

GI
MA
EM
LC
EC
FE
AT
TF
PD
AX
SU
BR
ST
RS
BT
HA
SC
EL
IDX

MEL831L

HEATED SEAT

Wiring Diagram — HSEAT — (Cont'd)

EL-HSEAT-02

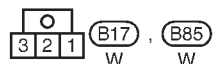
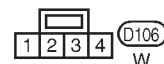
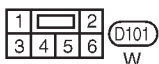
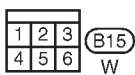
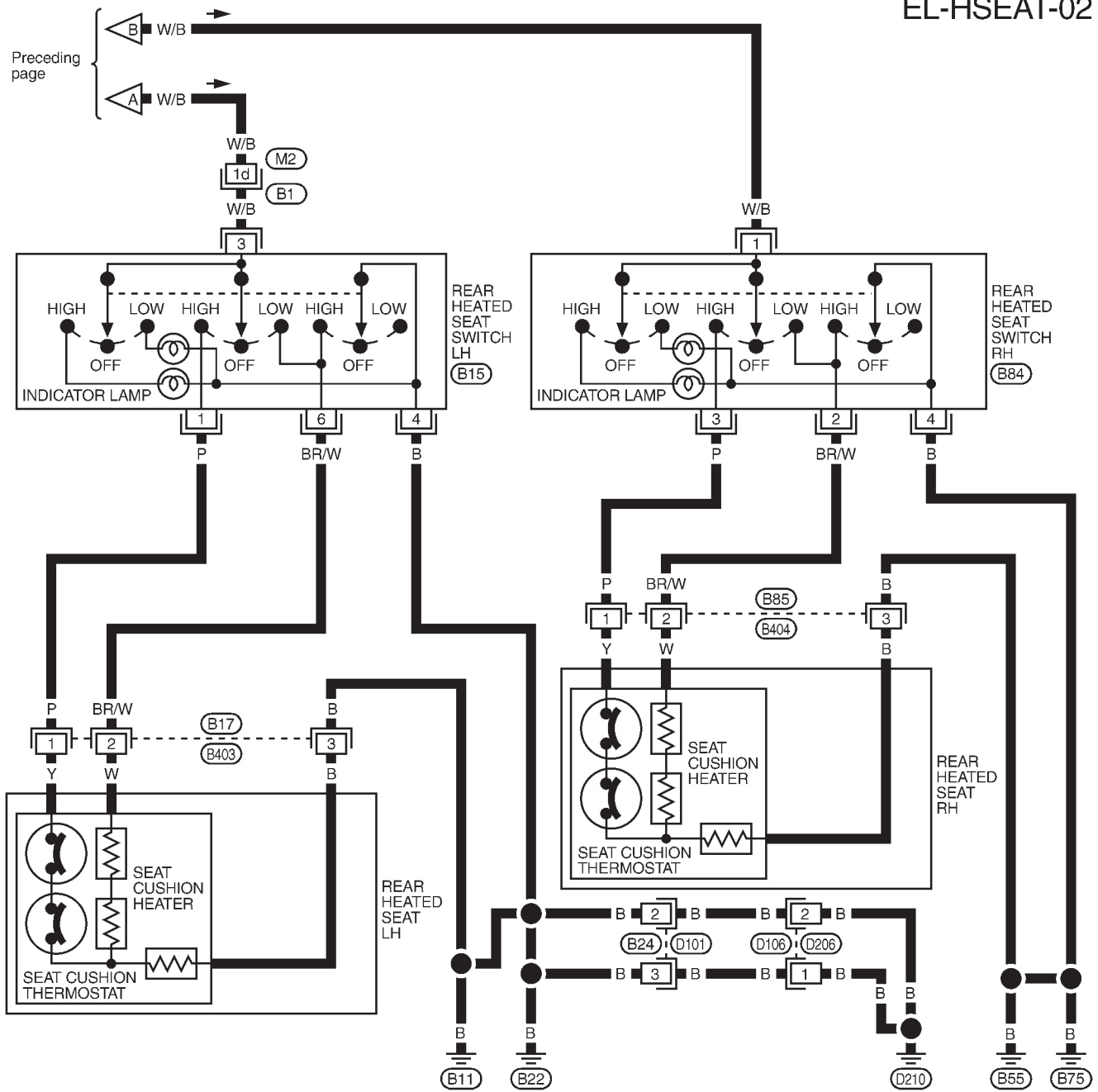

REFER TO THE FOLLOWING.

(B1) -SUPER
MULTIPLE JUNCTION (SMJ)

MEL832L

HEATED SEAT

Seatback Heating Unit

Seatback Heating Unit

NBEL0215

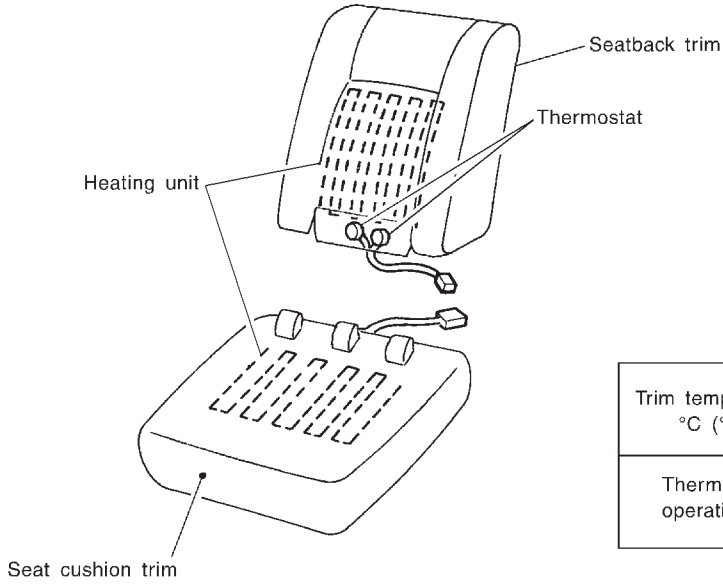

Trim temperature °C (°F)	Increasing to 35 - 45 (95 - 113)	Decreasing to 25 - 35 (77 - 95)
Thermostat operation	OFF	ON

SBT314

GI

MA

EM

LC

EC

FE

AT

TF

PD

AX

SU

BR

ST

RS

BT

HA

SC

EL

IDX

AUTOMATIC DRIVE POSITIONER

Component Parts and Harness Connector Location

Component Parts and Harness Connector Location

NBEL0209

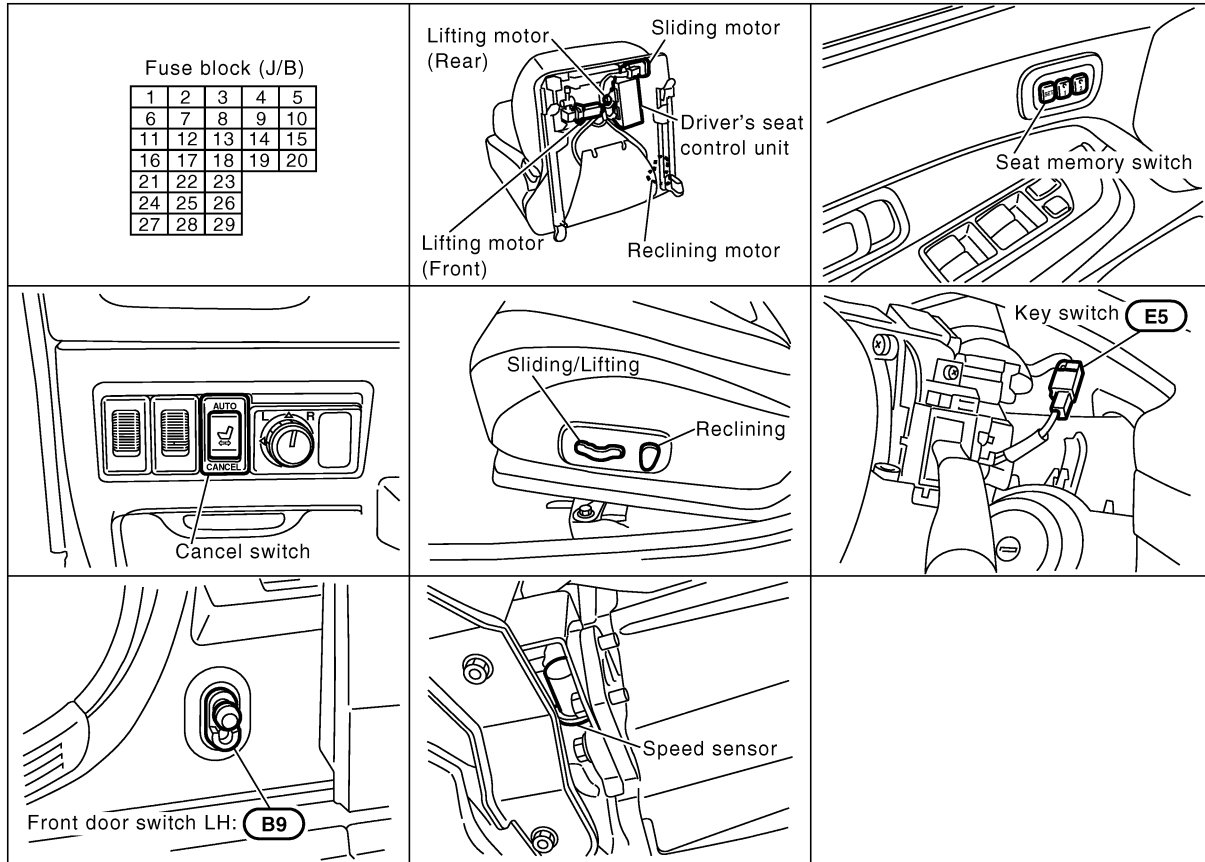

SEL353X

System Description

OPERATIVE CONDITION

The drive position can be set in 2 ways, manually and automatically.

=NBEL0210

NBEL0210S01

GI

Manual Operation

The driver's seat can be adjusted for sliding, reclining, front cushion height and rear cushion height with the LH power seat switches. The manual operation can be adjusted with the IGN key in any position.

NBEL0210S0101

MA

Automatic Operation

The driver's seat is adjusted to the proper positions for the driver automatically, in 3 different ways: MEMORY AUTOMATIC SET, AUTOMATIC EXITING SETTING and AUTOMATIC SET RETURN. (Automatic Drive Positioner = ADP)

NBEL0210S0102

EM

LC

CONDITIONS INHIBITING AUTOMATIC OPERATION

Automatic memory setting procedures are suspended under any of the following conditions:

NBEL0210S02

EC

- 1) When vehicle speed is more than 7 km/h (4 MPH).
- 2) When driver's side power seat switch is turned on.
- 3) When any two of the switches (set switch and memory switches 1 and 2) are turned ON.
- 4) When cancel switch is turned on.
- 5) When selector lever is in any position other than "P".
- 6) When ignition switch is turned to "START" position.
(Operation resumes when ignition switch is returned to "ON".)
- 7) When detention switch malfunction is detected:
 - Detention switch failure is sensed when detention switch remains off for at least 2 seconds at a vehicle speed of greater than 7 km/h (4 MPH).

FE

AT

TF

PD

FAIL-SAFE SYSTEM

Output Failure

When the ignition switch is in the ON position, if any of the parts (indicated in the following chart) move more than the specified amount within a period "T2" when no "ON" input is sent from any of the switches (indicated in the following chart), or an output from the automatic drive positioner is not produced, an output failure is sensed. Motor operation will be suspended automatically, and all automatic operations will be ineffective. (In this case, the motor will not operate manually.)

NBEL0210S03

AX

NBEL0210S0301

SU

OPERATED PORTION	T2	Allowable measurement
Seat sliding	Approx. 2.5 sec.	Within 6 mm (0.24 in)
Seat reclining	Same as above	Change angle within 1°

BR

ST

Absolving

When moving selector lever back to "P" position after having moved it to any position except "P", fail-safe operation will be canceled.

NBEL0210S0302

RS

BT

INITIALIZATION

After reconnecting battery cable, perform initialization procedure A or B. If initialization has not been performed, automatic drive positioner will not operate.

NBEL0210S04

HA

PROCEDURE A

- 1) Insert key in the ignition key cylinder. (Ignition switch is in "OFF" position.)
- 2) Open → close → open driver side door. (Do not perform with the door switch operation.)
- 3) End

SC

PROCEDURE B

- 1) Drive the vehicle at more than 25 km/h (16 MPH).
- 2) End

EL

IDX

AUTOMATIC DRIVE POSITIONER

System Description (Cont'd)

MEMORY AUTOMATIC SET

=NBEL0210S05

Two drive positions can be retained in the memory. Press memory switch to set driver's seat to preset position.

PROCEDURE FOR STORING MEMORY

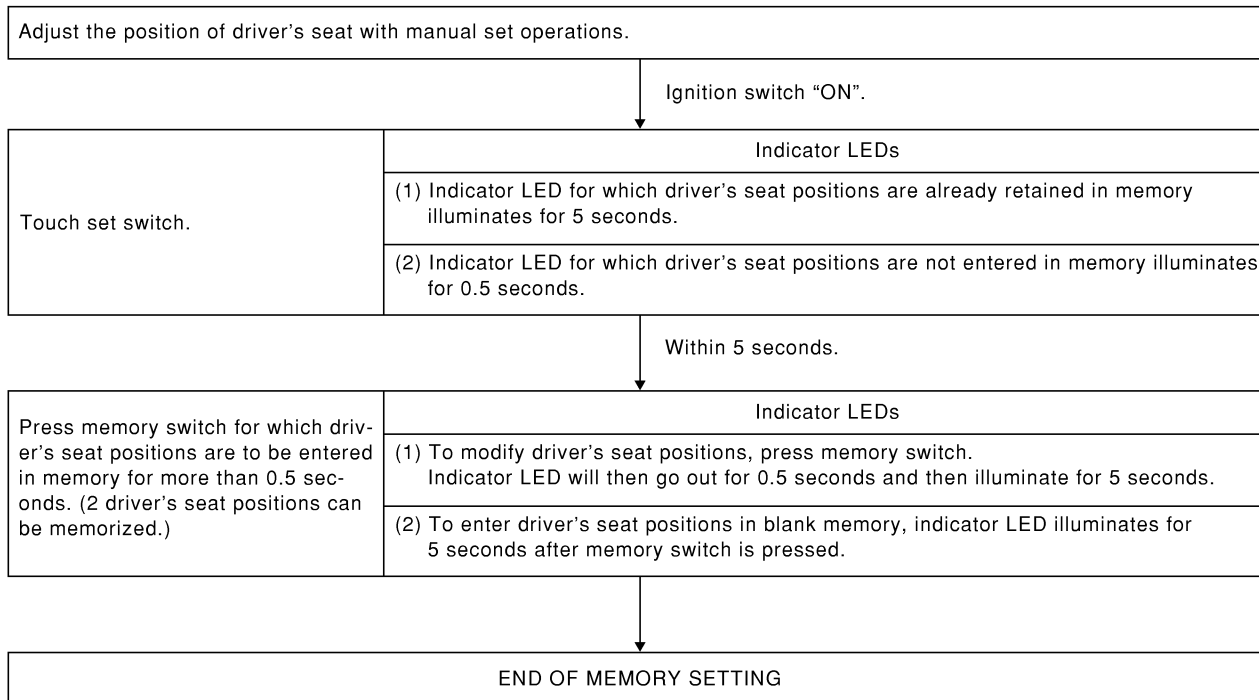

SEL592W

NOTE:

- When memory switch for which driver's seat positions are already retained in memory is pressed, new seat positions will be retained in memory in place of the previously set positions.
- Drive position is erased from the memory when battery cable is disconnected more than 30 seconds. After connecting battery cable, perform initialization procedures.

SELECTING THE MEMORIZED POSITION

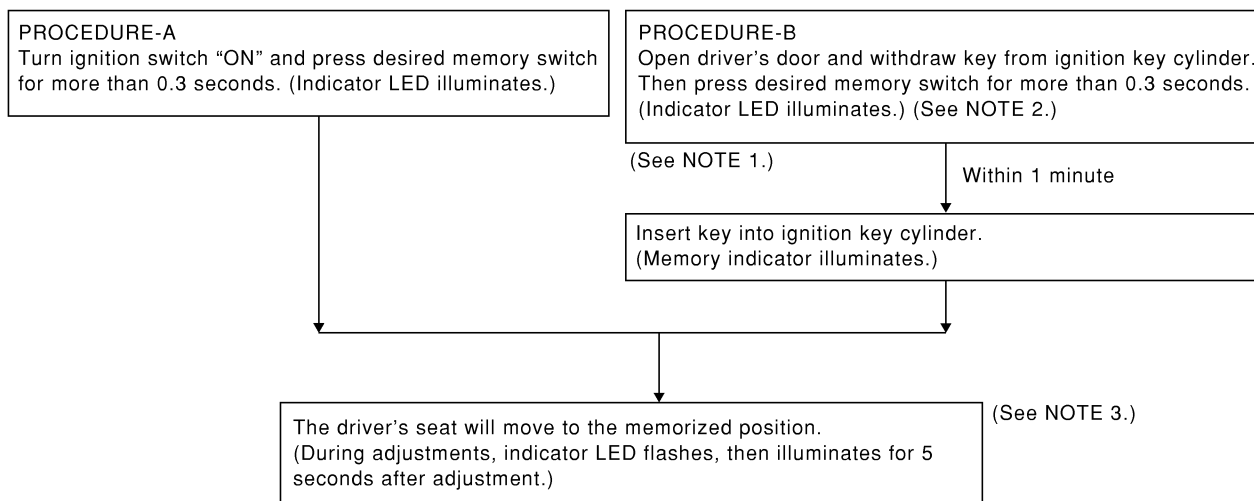

SEL593W

AUTOMATIC DRIVE POSITIONER

System Description (Cont'd)

NOTE:

- 1) Do not keep cancel switch pressed as it will not operate.
- 2) Automatic exiting setting will be performed.
- 3) The driver's seat position (see the following Table) operates in the order of priority.

The order of priority	Operated portion
1	Seat sliding
2	Seat reclining
3	Seat front lifting
4	Seat rear lifting

AUTOMATIC EXITING SETTING

NBEL0210S06

"Exiting" positions:

Driver's seat ... Slides about 40 mm (1.57 in) rear from normal sitting position.

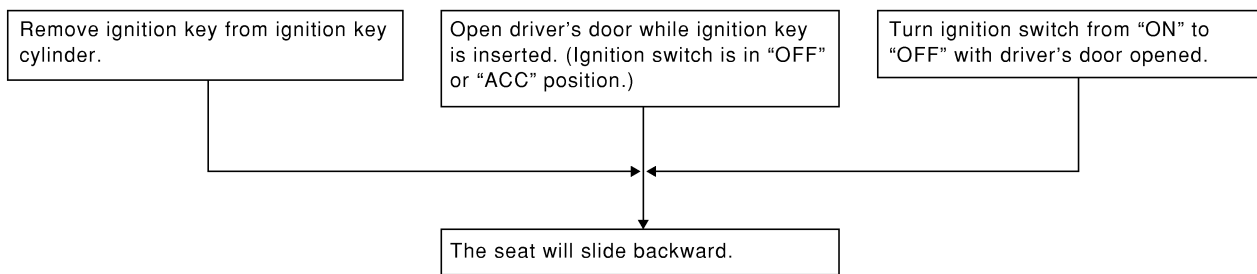

SEL594W

AUTOMATIC SET RETURN

NBEL0210S07

With driver's seat set to the "exiting" position, operating one of the following procedures moves it to the position previously retained in memory.

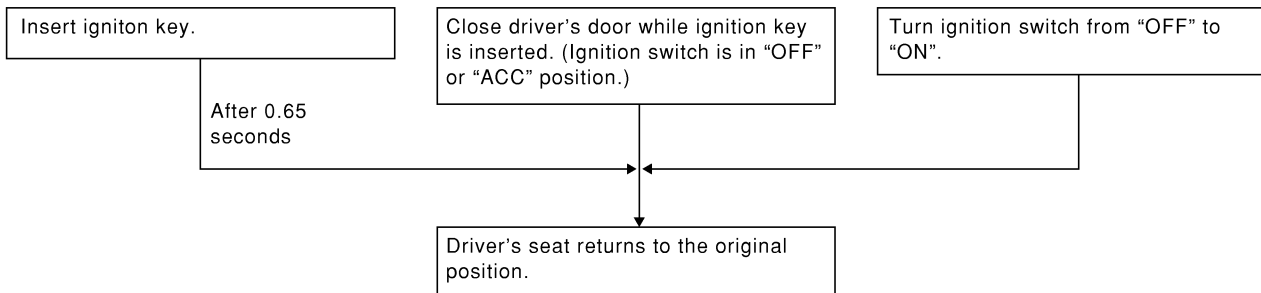

SEL595W

GI
MA
EM
LC
EC
FE
AT
TF
PD
AX
SU
BR
ST
RS
BT
HA
SC
EL
IDX

AUTOMATIC DRIVE POSITIONER

Schematic

Schematic

NBEL0211

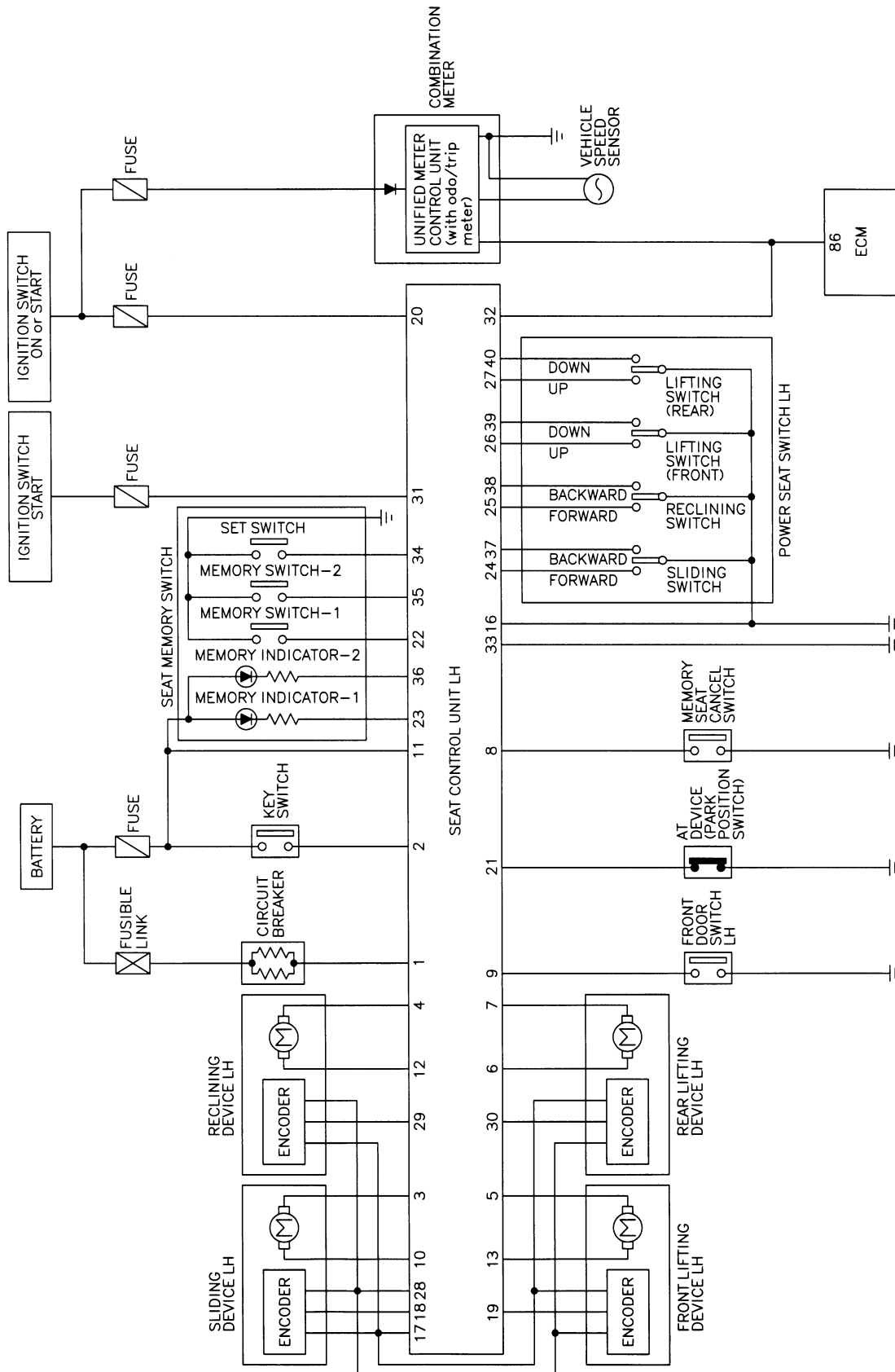

MEL833L

AUTOMATIC DRIVE POSITIONER

Wiring Diagram — AUT/DP —

Wiring Diagram — AUT/DP —

NBEL0212

EL-AUT/DP-01

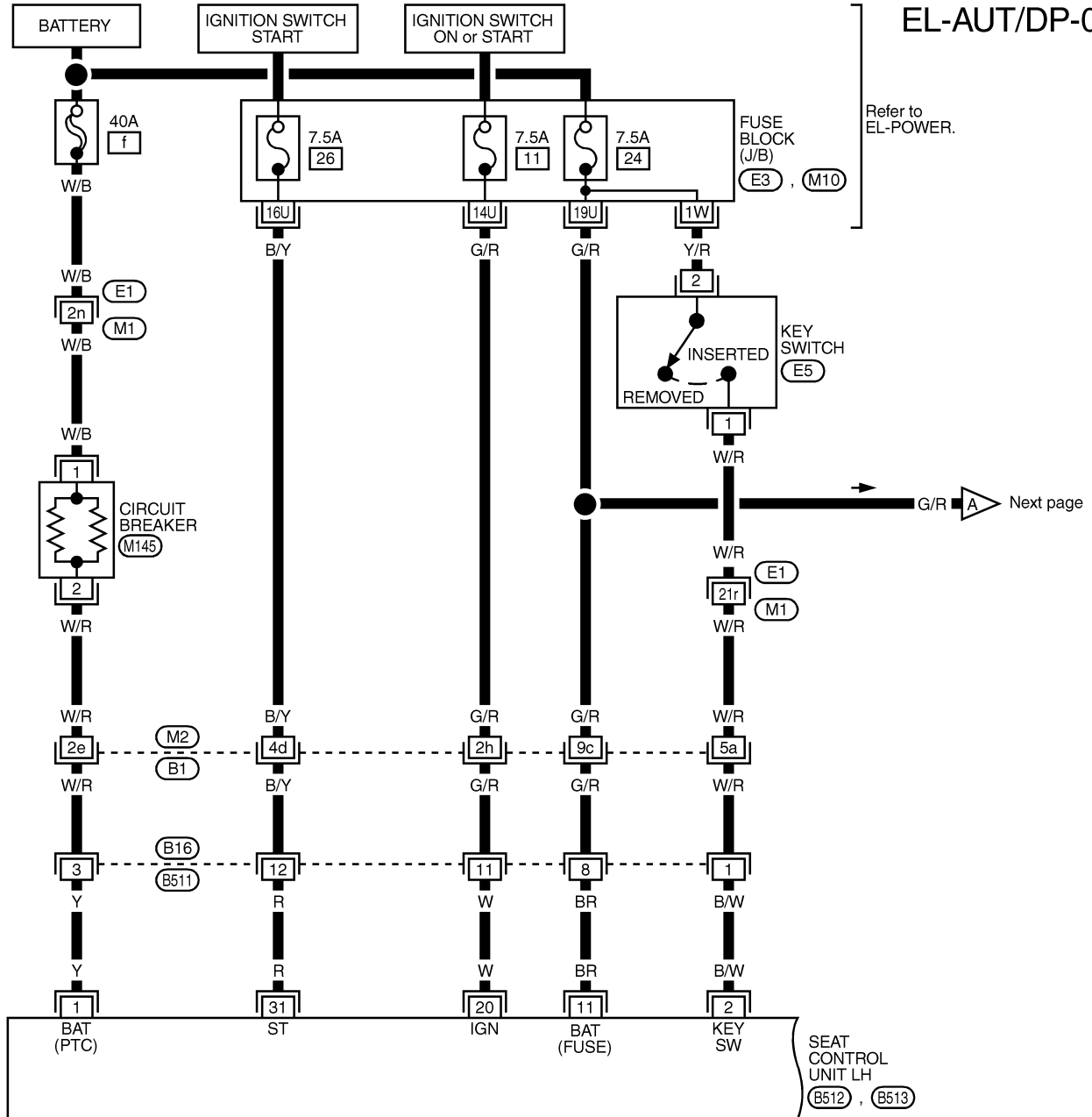

GI
MA
EM
LC
EC
FE
AT
TF
PD
AX
SU
BR
ST
RS
BT

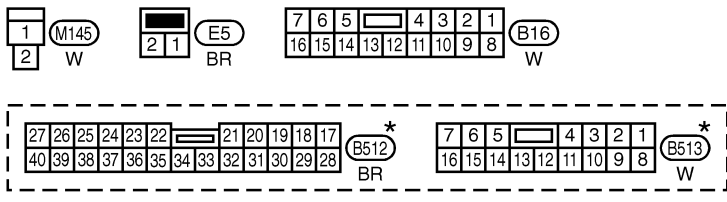

REFER TO THE FOLLOWING.
 (E1), (B1) -SUPER
 MULTIPLE JUNCTION (SMJ)
 (M10), (E3) -FUSE BLOCK-
 JUNCTION BOX (J/B)

HA
SC
EL
IDX

* : This connector is not shown in "HARNES LAYOUT", EL section.

AUTOMATIC DRIVE POSITIONER

Wiring Diagram — AUT/DP — (Cont'd)

EL-AUT/DP-02

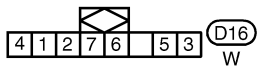
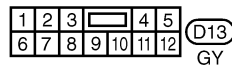
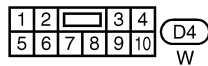
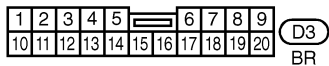
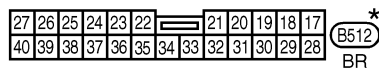
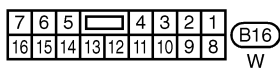
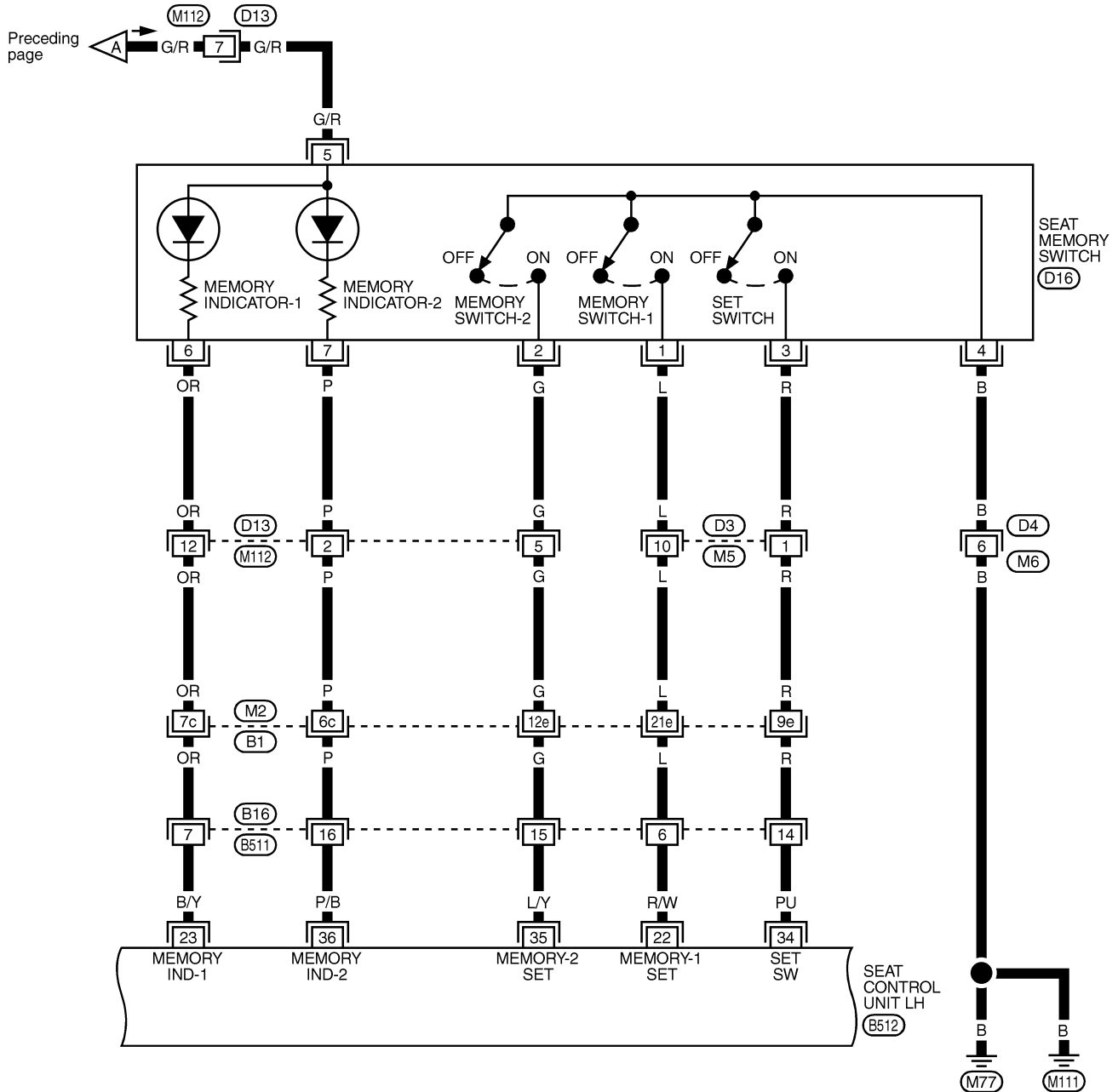

* : This connector is not shown in "HARNES LAYOUT", EL section.

REFER TO THE FOLLOWING.

- (B1) -SUPER
- MULTIPLE JUNCTION (SMJ)

MEL835L

AUTOMATIC DRIVE POSITIONER

Wiring Diagram — AUT/DP — (Cont'd)

EL-AUT/DP-03

GI
MA
EM
LC
EC
FE
AT
TF
PD
AX
SU
BR
ST
RS
BT
HA
SC
EL
IDX

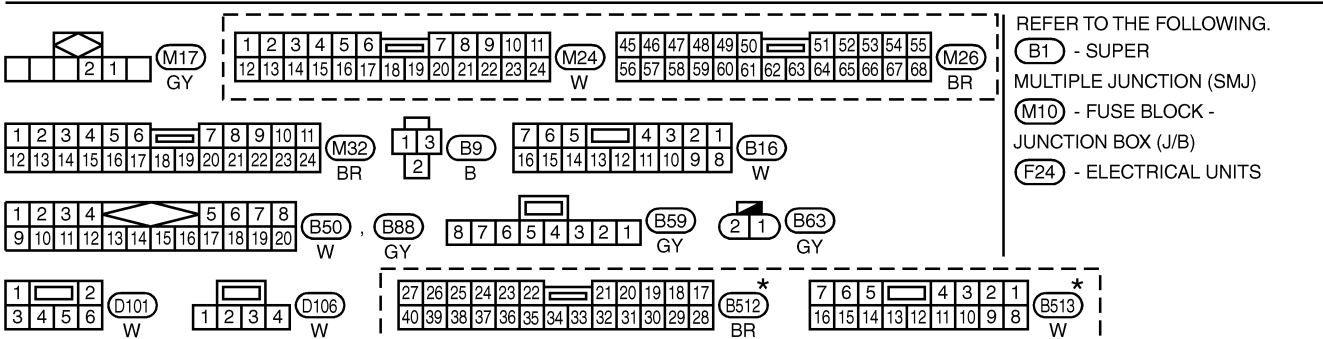
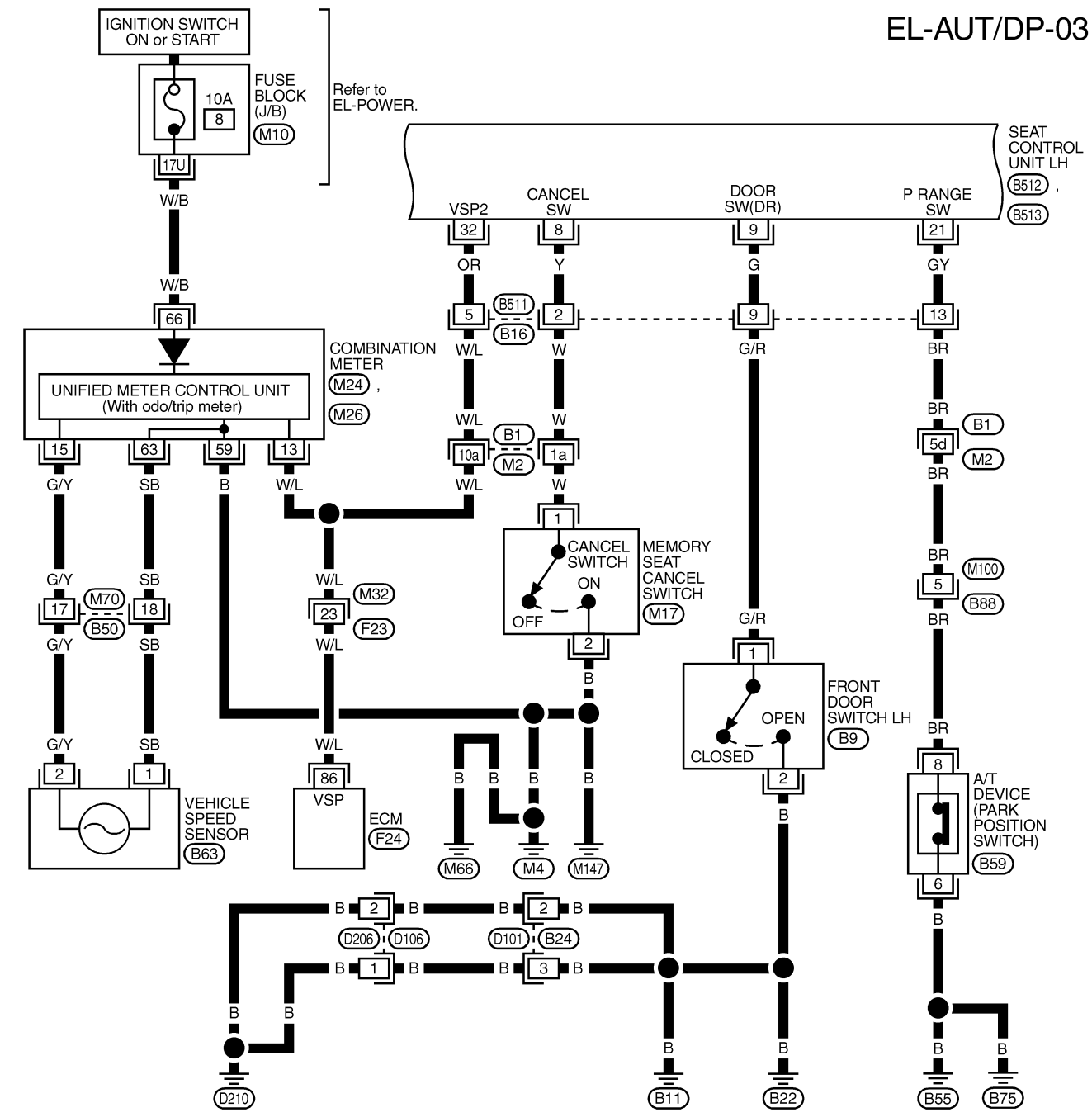

* : This connector is not shown in "HARNESS LAYOUT", EL section.

MEL836L

AUTOMATIC DRIVE POSITIONER

Wiring Diagram — AUT/DP — (Cont'd)

EL-AUT/DP-04

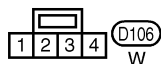
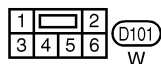
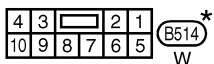
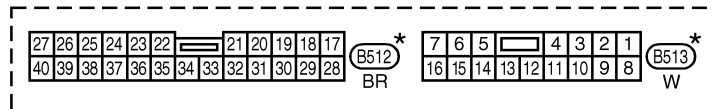
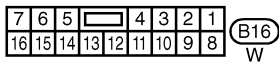
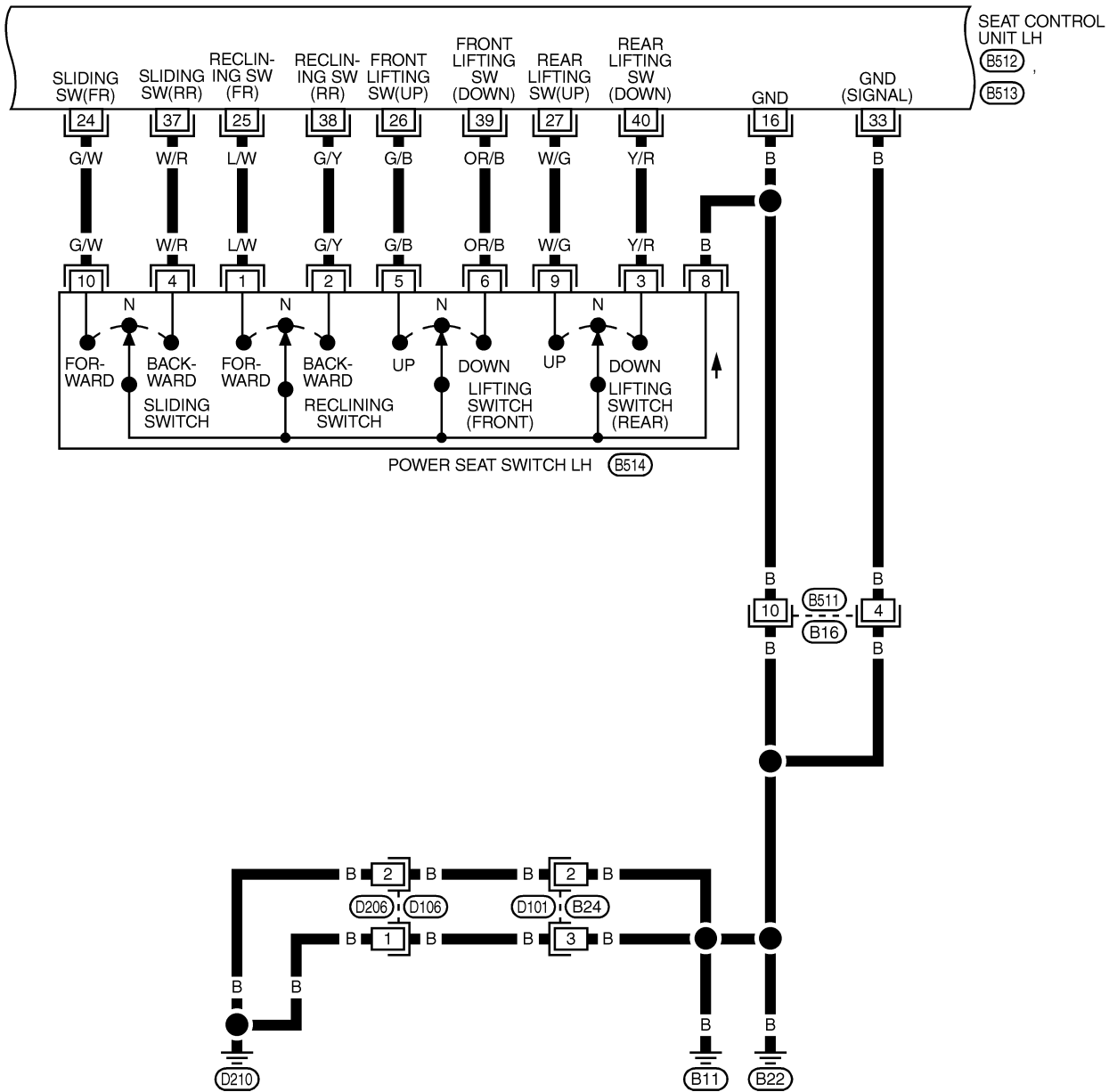

* : This connector is not shown in "HARNESS LAYOUT", EL section.

MEL186M

AUTOMATIC DRIVE POSITIONER

Wiring Diagram — AUT/DP — (Cont'd)

EL-AUT/DP-05

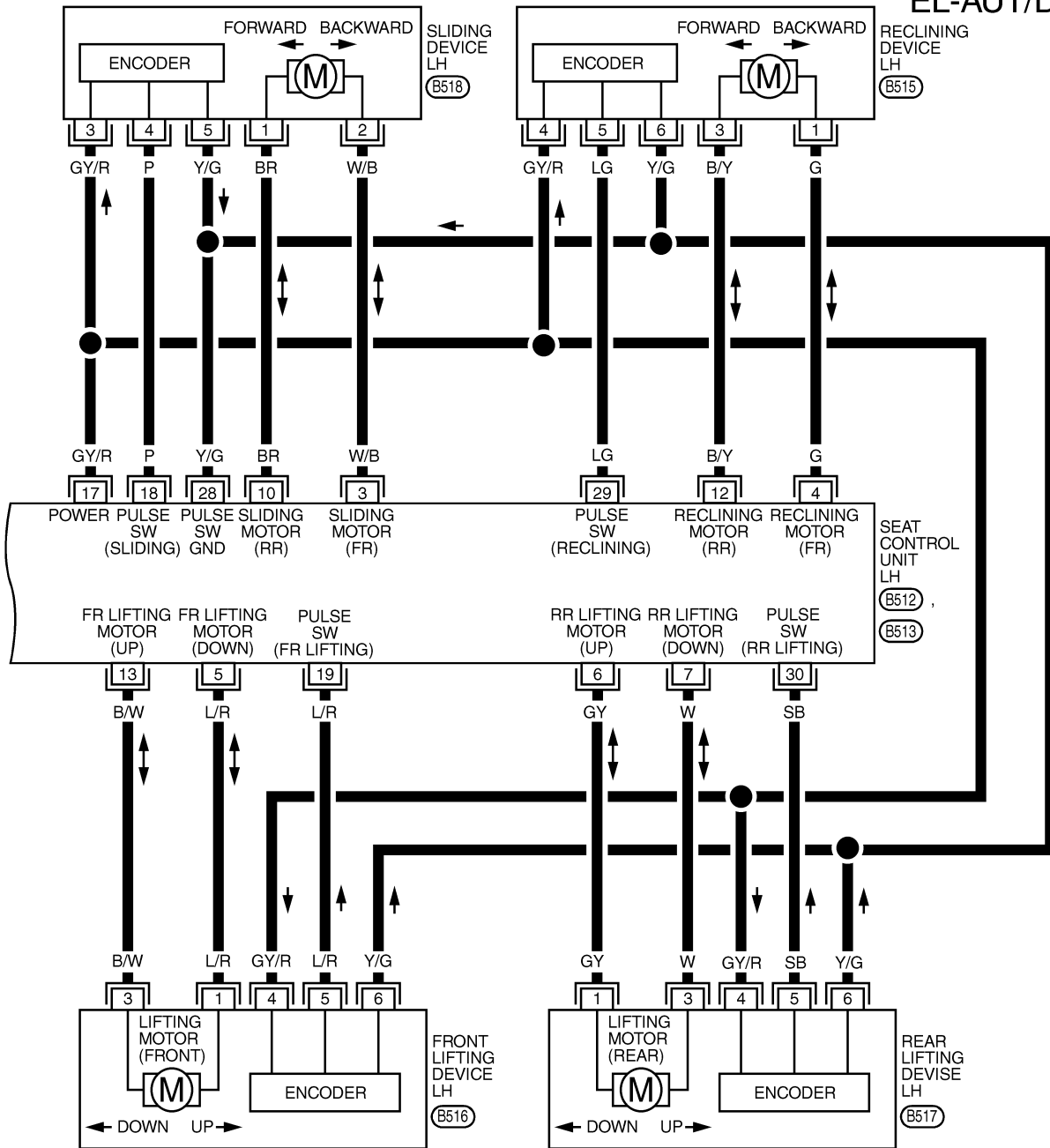

GI
 MA
 EM
 LC
 EC
 FE
 AT
 TF
 PD
 AX
 SU
 BR
 ST
 RS
 BT
 HA
 SC
 EL
 IDX

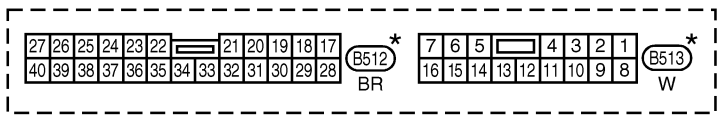

* : This connector is not shown in "HARNESS LAYOUT", EL section.

AUTOMATIC DRIVE POSITIONER

On Board Diagnosis

On Board Diagnosis

NBEL0213

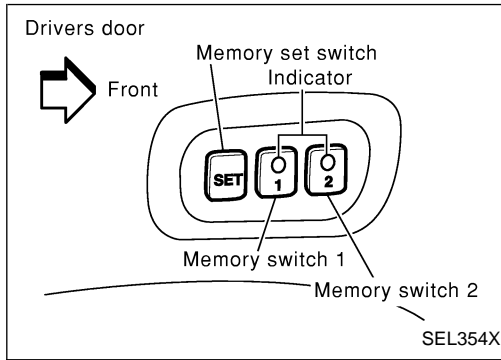

HOW TO PERFORM SELF-DIAGNOSIS

NBEL0213S01

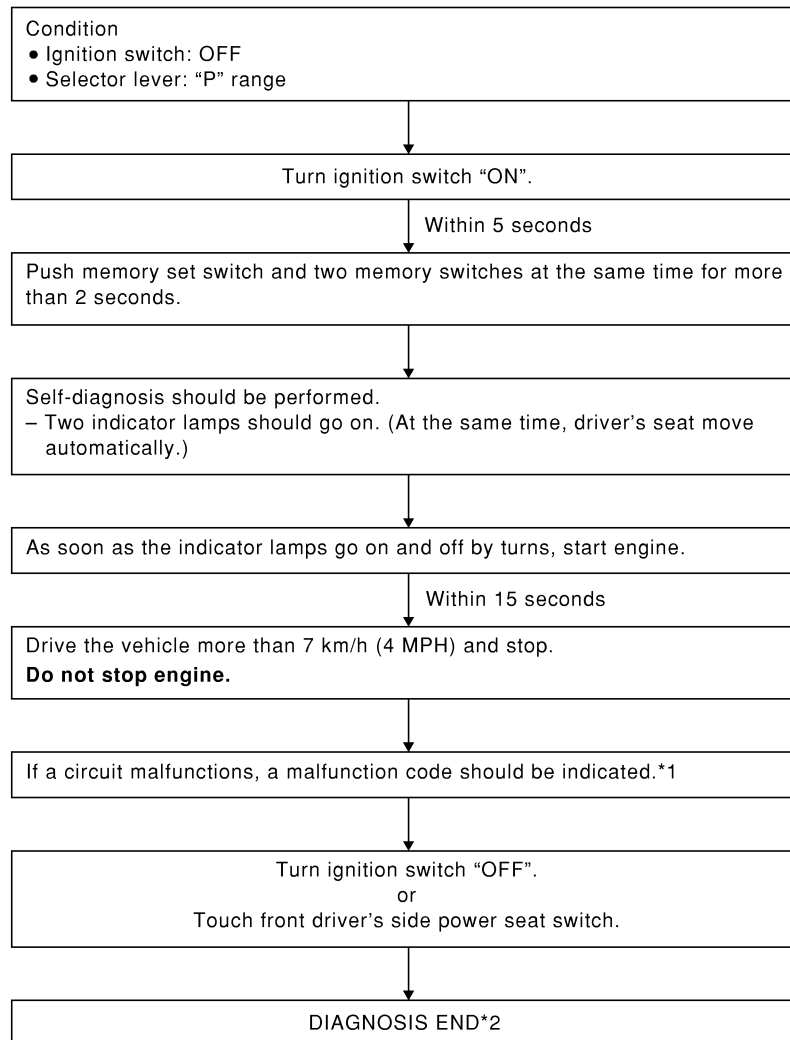

SEL596W

*1: If no malfunction is indicated, self-diagnosis will end after the vehicle speed sensor diagnosis is performed.

*2: Diagnosis ends after self-diagnostic results have been indicated for 10 minutes if left unattended.



AUTOMATIC DRIVE POSITIONER

On Board Diagnosis (Cont'd)

MALFUNCTION CODE TABLE

=NBEL0213S02

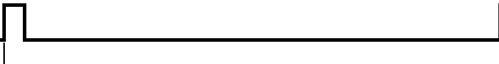
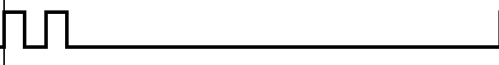
In this mode, a malfunction code is indicated by the number of flashes from the automatic drive positioner indicator lamps (indicator lamp 1, indicator lamp 2) as shown below.

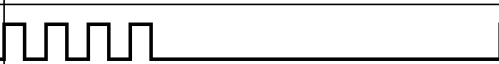
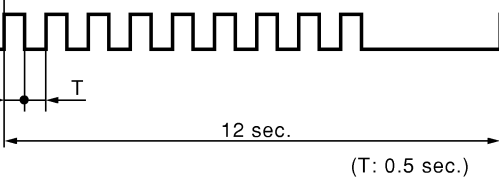
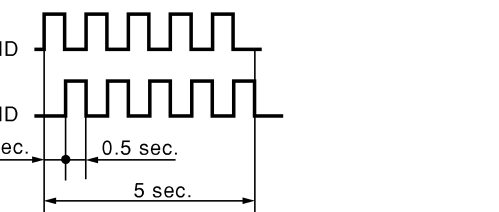
Code No.	Detected items	Indication of seat memory switches 1 and 2	Explanation
1	Seat sliding	IND1, IND2 	While the seat motors are moving for 2.5 seconds, if the number of seat sliding/reclining/lifting encoder pulses changes 2 times or less, the seat device is determined to be malfunctioning.
2	Seat reclining	IND1, IND2 	
3	Seat lifting front	IND1, IND2 	
4	Seat lifting rear	IND1, IND2 	
9	Vehicle speed sensor circuit	IND1, IND2 	If the vehicle speed sensor output of less than 7 km/h (4 MPH) is detected, the vehicle speed sensor is determined to be malfunctioning.
-	No malfunction in the above items	SW1 IND 	—

SEL597W

Code No.	Detected items	Diagnostic procedure	Reference page	Code No.	Detected items	Diagnostic procedure	Reference page
1	Seat sliding	PROCEDURE 2 (Sliding encoder check) PROCEDURE 6 (Sliding motor check)	EL-203 EL-211	4	Seat lifting rear	PROCEDURE 5 [Lifting encoder (rear) check] PROCEDURE 9 [Lifting motor (rear) check]	EL-209 EL-214
2	Seat reclining	PROCEDURE 3 (Reclining encoder check) PROCEDURE 7 (Reclining motor check)	EL-205 EL-212	9	Vehicle speed sensor	PROCEDURE 12 (Vehicle speed sensor check)	EL-217
3	Seat lifting front	PROCEDURE 4 [Lifting encoder (front) check] PROCEDURE 8 [Lifting motor (front) check]	EL-207 EL-213				

AUTOMATIC DRIVE POSITIONER

Trouble Diagnoses WORK FLOW

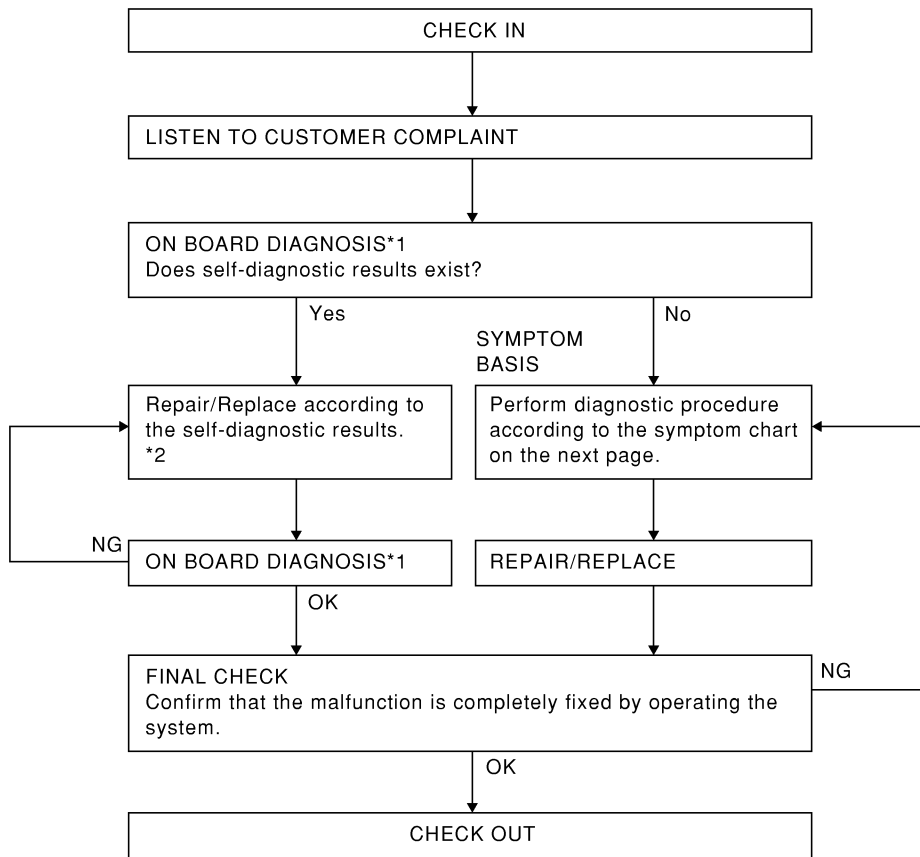

*1 EL-196

*2 EL-197

PRELIMINARY CHECK

NBEL0214S02

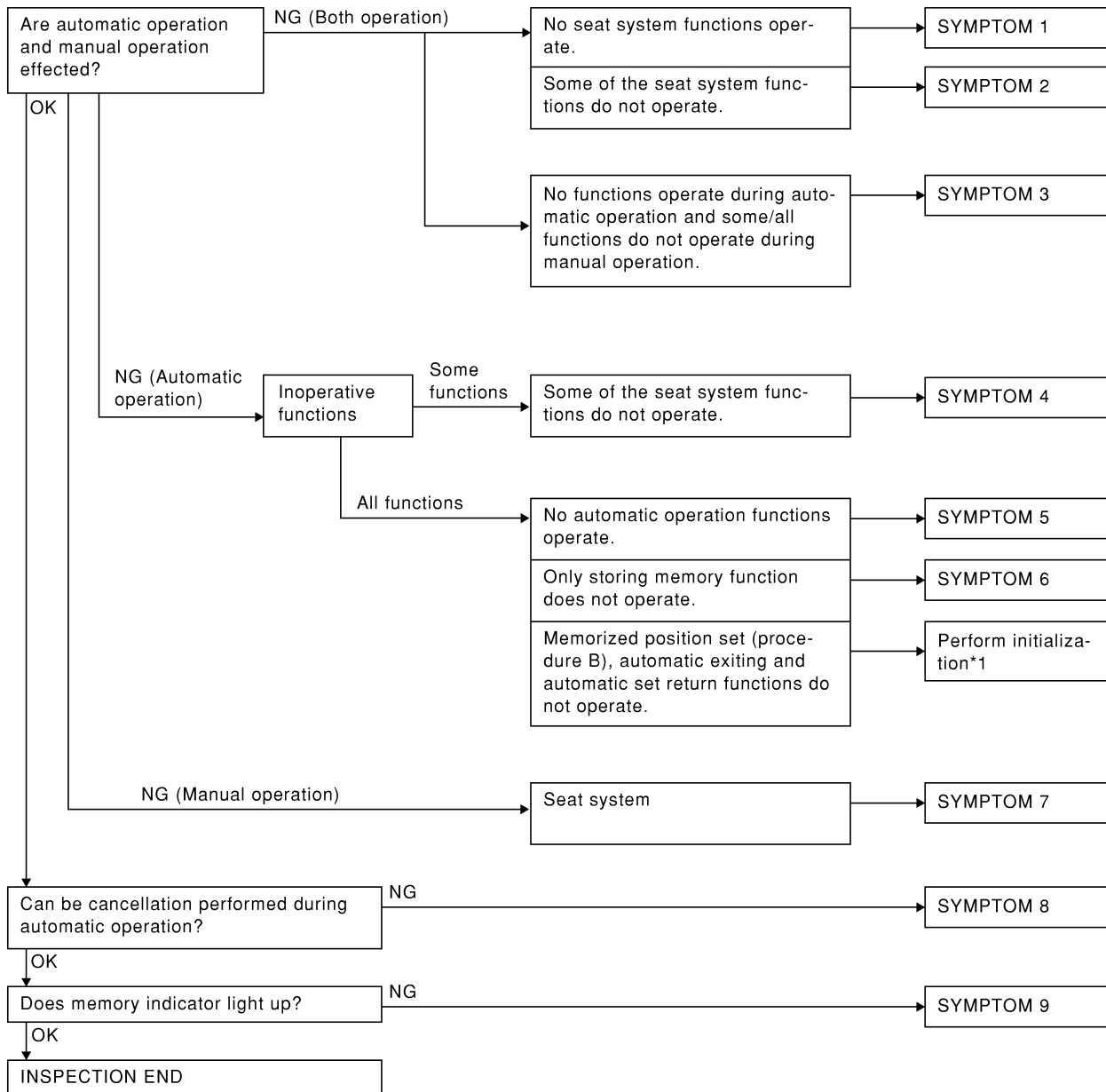

GI
 MA
 EM
 LC
 EC
 FE
 AT
 TF
 PD
 AX
 SU
 BR
 ST
 RS
 BT

SEL600W

HA

*1: After reconnecting battery cable, perform initialization procedure A or B.
 If initialization has not been performed, automatic drive positioner will not operate.

PROCEDURE A

- 1) Insert key in the ignition key cylinder. (Ignition switch is in "OFF" position.)
- 2) Open → close → open driver side door. (Do not perform with the door switch operation.)
- 3) End

PROCEDURE B

- 1) Drive the vehicle at more than 30 km/h (19 MPH).

EL

IDX

AUTOMATIC DRIVE POSITIONER

Trouble Diagnoses (Cont'd)

2) End

After performing preliminary check, go to symptom chart below.

Before starting trouble diagnoses below, perform preliminary check, EL-199. Symptom numbers in the symptom chart correspond with those of preliminary check.

SYMPTOM CHART

NBEL0214S03

PROCEDURE		Diagnostic procedure						
REFERENCE PAGE (EL-)		202	203	205	207	209	211	212
SYMPTOM		DIAGNOSTIC PROCEDURE 1 (Power supply and ground circuit for Driver's seat control unit)	DIAGNOSTIC PROCEDURE 2 (Sliding encoder check)	DIAGNOSTIC PROCEDURE 3 (Reclining encoder check)	DIAGNOSTIC PROCEDURE 4 [Lifting encoder (front) check]	DIAGNOSTIC PROCEDURE 5 [Lifting encoder (rear) check]	DIAGNOSTIC PROCEDURE 6 (Sliding motor check)	DIAGNOSTIC PROCEDURE 7 (Reclining motor check)
1	No seat system functions operate.	X						
2	Some of the seat system functions do not operate during automatic/manual operation.	Sliding					X	
		Reclining						X
		Lifting (Front)						
		Lifting (Rear)						
3	No functions operate during automatic operation, and some/all functions do not during manual operation.							
4	Some of the seat system functions do not operate during automatic operation.	Sliding		X				
		Reclining			X			
		Lifting (Front)				X		
		Lifting (Rear)					X	
5	No automatic operation functions operate.							
6	Drive position cannot be retained in the memory.							
7	Does not operate during manual operation. (Operates during automatic operation.)	Sliding						
		Reclining						
		Lifting (Front)						
		Lifting (Rear)						
8	Automatic operation cannot be canceled.							
9	Memory indicator does not light up.							

X : Applicable

AUTOMATIC DRIVE POSITIONER

Trouble Diagnoses (Cont'd)

PROCEDURE		Diagnostic procedure							
REFERENCE PAGE (EL-)		213	214	215	216	217	220	220	
SYMPTOM		DIAGNOSTIC PROCEDURE 8 [Lifting motor (front) check]	DIAGNOSTIC PROCEDURE 9 [Lifting motor (rear) check]	DIAGNOSTIC PROCEDURE 10 (Power seat switch check)	DIAGNOSTIC PROCEDURE 11 (Cancel switch check)	DIAGNOSTIC PROCEDURE 12 (Key, park position, door switch and vehicle speed sensor check)	DIAGNOSTIC PROCEDURE 13 (Seat memory switch check)	DIAGNOSTIC PROCEDURE 14 (Memory indicator check)	
1	No seat system functions operate.								GI
2	Some of the seat system functions do not operate during automatic/manual operation.	Sliding							FE
		Reclining							AT
		Lifting (Front)	X						TF
		Lifting (Rear)		X					PD
3	No functions operate during automatic operation, and some/all functions do not during manual operation.			X		X (ACC, ON START signal)			AX
4	Some of the seat system functions do not operate during automatic operation.	Sliding							SU
		Reclining							BR
		Lifting (Front)							ST
		Lifting (Rear)							RS
5	No automatic operation functions operate.				X	X			BT
6	Drive position cannot be retained in the memory.					X (IGN ON signal)	X		HA
7	Does not operate during manual operation. (Operates during automatic operation.)	Sliding		X					SC
		Reclining			X				
		Lifting (Front)			X				
		Lifting (Rear)			X				
8	Automatic operation cannot be canceled.				X				EL
9	Memory indicator does not light up.							X	IDX

X : Applicable

AUTOMATIC DRIVE POSITIONER

Trouble Diagnoses (Cont'd)

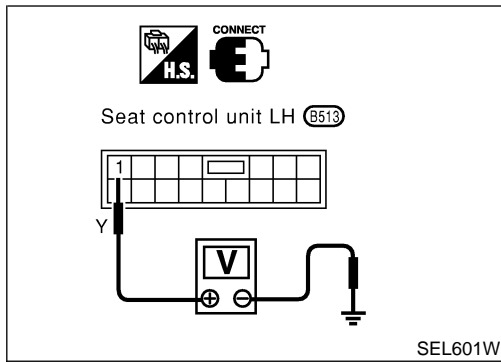

DIAGNOSTIC PROCEDURE 1

(Power supply and ground circuit for driver's seat control unit) =NBEL0214S04

Power Supply Circuit Check

Check voltage between seat control unit LH terminal 1 and ground. NBEL0214S0401

Terminals	Ignition switch position			
	OFF	ACC	ON	START
1 - Ground	Battery voltage			

If NG, check the following.

- 40A fusible link (letter f, located in the fuse and fusible link box)
- Circuit breaker
- Harness for open or short between circuit breaker and seat control unit LH

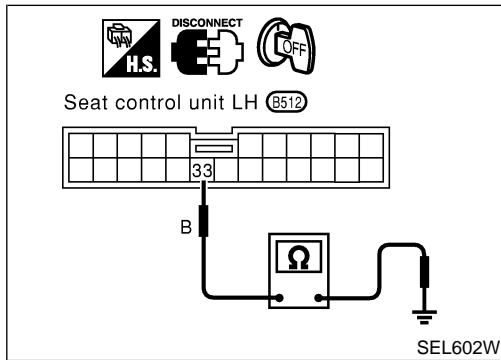

Ground Circuit Check

Check continuity between seat control unit LH terminal 33 and ground. NBEL0214S0402

Terminals	Continuity
33 - Ground	Yes

DIAGNOSTIC PROCEDURE 2 (Sliding encoder check)

=NBEL0214S05

1	CHECK SLIDING ENCODER OUTPUT SIGNAL	<p>Measure voltage between seat control unit LH terminal 18 and ground with CONSULT-II or oscilloscope when power seat slide is operated.</p> <div style="display: flex; justify-content: space-around; align-items: flex-start;"> <div style="text-align: center;"> <p>Seat control unit LH (8512)</p> </div> <div style="text-align: center;"> <p>HI: Approx. 5V LO: Approx. 0V</p> </div> </div> <p style="text-align: right;">SEL603W</p>
OK or NG		

OK	▶	Sliding encoder is OK.
NG	▶	GO TO 2.

2	CHECK SLIDING ENCODER INPUT SIGNAL	<p>Check voltage between seat control unit LH terminal 17 and ground.</p> <div style="display: flex; justify-content: space-around; align-items: flex-start;"> <div style="text-align: center;"> <p>Seat control unit LH (8512)</p> </div> <div style="text-align: center;"> <p>Battery voltage should exist.</p> </div> </div> <p style="text-align: right;">SEL604W</p>
OK or NG		

OK	▶	GO TO 3.
NG	▶	Replace seat control unit LH.

GI
MA
EM
LC
EC
FE
AT
TF
PD
AX
SU
BR
ST
RS
BT
HA
SC
EL
IDX

AUTOMATIC DRIVE POSITIONER

Trouble Diagnoses (Cont'd)

3	CHECK SLIDING ENCODER OPEN CIRCUIT												
<p>1. Disconnect seat control unit LH connector and sliding device LH connector.</p> <p>2. Check harness continuity between seat control unit LH connector and sliding device LH connector.</p>													
<table border="1" style="margin-left: auto; margin-right: 0;"> <thead> <tr> <th colspan="2">Terminals</th> <th rowspan="2">Continuity</th> </tr> <tr> <th>Seat control unit LH</th> <th>Sliding device LH (Sliding encoder)</th> </tr> </thead> <tbody> <tr> <td>17</td> <td>3</td> <td rowspan="3" style="text-align: center;">Yes</td> </tr> <tr> <td>18</td> <td>4</td> </tr> <tr> <td>28</td> <td>5</td> </tr> </tbody> </table>		Terminals		Continuity	Seat control unit LH	Sliding device LH (Sliding encoder)	17	3	Yes	18	4	28	5
Terminals		Continuity											
Seat control unit LH	Sliding device LH (Sliding encoder)												
17	3	Yes											
18	4												
28	5												
SEL605WA													
OK or NG													
OK	▶	GO TO 4.											
NG	▶	Repair harness.											

4	CHECK SLIDING ENCODER SHORT CIRCUIT						
Check harness continuity between seat control unit LH connector and ground.							
<table border="1" style="margin-left: auto; margin-right: 0;"> <thead> <tr> <th>Terminals</th> <th>Continuity</th> </tr> </thead> <tbody> <tr> <td>17 - Ground</td> <td rowspan="3" style="text-align: center;">No</td> </tr> <tr> <td>18 - Ground</td> </tr> <tr> <td>28 - Ground</td> </tr> </tbody> </table>		Terminals	Continuity	17 - Ground	No	18 - Ground	28 - Ground
Terminals	Continuity						
17 - Ground	No						
18 - Ground							
28 - Ground							
SEL606W							
OK or NG							
OK	▶	Replace sliding encoder.					
NG	▶	Repair harness.					

DIAGNOSTIC PROCEDURE 3 (Reclining encoder check)

=NBEL0214S06

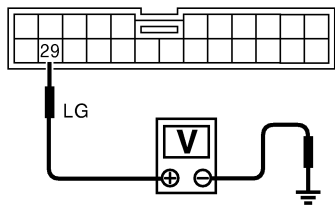
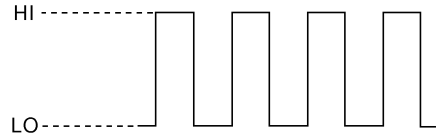
1	CHECK RECLINING ENCODER OUTPUT SIGNAL	<p>Measure voltage between seat control unit LH terminal 29 and ground with CONSULT-II or oscilloscope when power seat reclining is operated.</p> <div style="display: flex; justify-content: space-between; align-items: flex-start;"> <div style="text-align: center;">  <p>Seat control unit LH (B512)</p>  </div> <div style="text-align: center;">  <p>HI: Approx. 5V LO: Approx. 0V</p> </div> </div> <p style="text-align: right;">SEL607W</p> <p style="text-align: center;">OK or NG</p>	GI MA EM LC EC FE
OK	▶	Reclining encoder is OK.	AT
NG	▶	GO TO 2.	TF

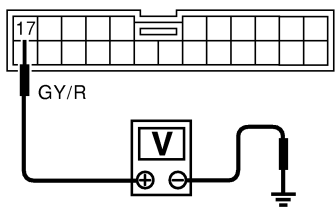
2	CHECK RECLINING ENCODER INPUT SIGNAL	<p>Check voltage between seat control unit LH terminal 17 and ground.</p> <div style="display: flex; justify-content: space-between; align-items: flex-start;"> <div style="text-align: center;">  <p>Seat control unit LH (B512)</p>  </div> <div style="text-align: center;"> <p>Battery voltage should exist.</p> </div> </div> <p style="text-align: right;">SEL608W</p> <p style="text-align: center;">OK or NG</p>	PD AX SU BR ST
OK	▶	GO TO 3.	RS
NG	▶	Replace seat control unit LH.	BT HA SC

GI
MA
EM
LC
EC
FE
AT
TF
PD
AX
SU
BR
ST
RS
BT
HA
SC
EL
IDX

AUTOMATIC DRIVE POSITIONER

Trouble Diagnoses (Cont'd)

3	CHECK RECLINING ENCODER OPEN CIRCUIT	
<p>1. Disconnect seat control unit LH connector and reclining device LH connector.</p> <p>2. Check harness continuity between seat control unit LH connector and reclining LH connector.</p>		
SEL609WA		
OK or NG		
OK	▶	GO TO 4.
NG	▶	Repair harness.

4	CHECK RECLINING ENCODER SHORT CIRCUIT	
<p>Check harness continuity between seat control unit LH connector and ground.</p>		
SEL610W		
OK or NG		
OK	▶	Replace reclining encoder.
NG	▶	Repair harness.

AUTOMATIC DRIVE POSITIONER

Trouble Diagnoses (Cont'd)

DIAGNOSTIC PROCEDURE 4

[Lifting encoder (front) check]

=NBEL0214S07

1	CHECK LIFTING ENCODER (FRONT) OUTPUT SIGNAL	
<p>Measure voltage between seat control unit LH terminal 19 and ground with CONSULT-II or oscilloscope when power seat lifting (front) is operated.</p>		
SEL611W		
OK or NG		
OK	▶	Lifting encoder (front) is OK.
NG	▶	GO TO 2.

2	CHECK LIFTING ENCODER (FRONT) INPUT SIGNAL	
<p>Check voltage between seat control unit LH terminal 17 and ground.</p>		
SEL612W		
OK or NG		
OK	▶	GO TO 3.
NG	▶	Replace seat control unit LH.

GI
 MA
 EM
 LC
 EC
 FE
 AT
 TF
 PD
 AX
 SU
 BR
 ST
 RS
 BT
 HA
 SC
 EL
 IDX

AUTOMATIC DRIVE POSITIONER

Trouble Diagnoses (Cont'd)

3	CHECK LIFTING ENCODER (FRONT) OPEN CIRCUIT													
<p>1. Disconnect seat control unit LH connector and front lifting device LH connector.</p> <p>2. Check harness continuity between seat control unit LH connector and front lifting device LH connector.</p>														
<table border="1" style="margin-left: auto; margin-right: auto;"> <thead> <tr> <th colspan="2">Terminals</th> <th rowspan="2">Continuity</th> </tr> <tr> <th>Seat control unit LH</th> <th>Front lifting device LH Lifting encoder (front)</th> </tr> </thead> <tbody> <tr> <td style="text-align: center;">17</td> <td style="text-align: center;">4</td> <td rowspan="3" style="text-align: center;">Yes</td> </tr> <tr> <td style="text-align: center;">19</td> <td style="text-align: center;">5</td> </tr> <tr> <td style="text-align: center;">28</td> <td style="text-align: center;">6</td> </tr> </tbody> </table>		Terminals		Continuity	Seat control unit LH	Front lifting device LH Lifting encoder (front)	17	4	Yes	19	5	28	6	
Terminals		Continuity												
Seat control unit LH	Front lifting device LH Lifting encoder (front)													
17	4	Yes												
19	5													
28	6													
SEL613WA														
OK or NG														
OK	▶	GO TO 4.												
NG	▶	Repair harness.												

4	CHECK LIFTING ENCODER (FRONT) SHORT CIRCUIT							
<p>Check harness continuity between seat control unit LH connector and ground.</p>								
<table border="1" style="margin-left: auto; margin-right: auto;"> <thead> <tr> <th>Terminals</th> <th>Continuity</th> </tr> </thead> <tbody> <tr> <td>17 - Ground</td> <td rowspan="3" style="text-align: center;">No</td> </tr> <tr> <td>19 - Ground</td> </tr> <tr> <td>28 - Ground</td> </tr> </tbody> </table>		Terminals	Continuity	17 - Ground	No	19 - Ground	28 - Ground	
Terminals	Continuity							
17 - Ground	No							
19 - Ground								
28 - Ground								
SEL614W								
OK or NG								
OK	▶	Replace lifting encoder (front).						
NG	▶	Repair harness.						

DIAGNOSTIC PROCEDURE 5 [Lifting encoder (rear) check]

=NBEL0214S08

1	CHECK LIFTING ENCODER (REAR) OUTPUT SIGNAL	<p>Measure voltage between seat control unit LH terminal 30 and ground with CONSULT-II or oscilloscope when power seat lifting (rear) is operated.</p> <div style="display: flex; justify-content: space-around; align-items: flex-start;"> <div style="text-align: center;"> <p>Seat control unit LH (E512)</p> </div> <div style="text-align: center;"> <p>HI: Approx. 5V LO: Approx. 0V</p> </div> </div> <p style="text-align: right;">SEL615W</p> <p style="text-align: center;">OK or NG</p> <table border="1" style="width: 100%; border-collapse: collapse;"> <tr> <td style="width: 15%;">OK</td> <td style="width: 10%; text-align: center;">▶</td> <td>Lifting encoder (rear) is OK.</td> </tr> <tr> <td>NG</td> <td style="text-align: center;">▶</td> <td>GO TO 2.</td> </tr> </table>		OK	▶	Lifting encoder (rear) is OK.	NG	▶	GO TO 2.
OK	▶	Lifting encoder (rear) is OK.							
NG	▶	GO TO 2.							

2	CHECK LIFTING ENCODER (REAR) INPUT SIGNAL	<p>Check voltage between seat control unit LH terminal 17 and ground.</p> <div style="display: flex; justify-content: space-around; align-items: flex-start;"> <div style="text-align: center;"> <p>Seat control unit LH (E512)</p> </div> <div style="text-align: center;"> <p>Battery voltage should exist.</p> </div> </div> <p style="text-align: right;">SEL616W</p> <p style="text-align: center;">OK or NG</p> <table border="1" style="width: 100%; border-collapse: collapse;"> <tr> <td style="width: 15%;">OK</td> <td style="width: 10%; text-align: center;">▶</td> <td>GO TO 3.</td> </tr> <tr> <td>NG</td> <td style="text-align: center;">▶</td> <td>Replace seat control unit LH.</td> </tr> </table>		OK	▶	GO TO 3.	NG	▶	Replace seat control unit LH.
OK	▶	GO TO 3.							
NG	▶	Replace seat control unit LH.							

GI
MA
EM
LC
EC
FE
AT
TF
PD
AX
SU
BR
ST
RS
BT
HA
SC
EL
IDX

AUTOMATIC DRIVE POSITIONER

Trouble Diagnoses (Cont'd)

3	CHECK LIFTING ENCODER (REAR) OPEN CIRCUIT	
<p>1. Disconnect seat control unit LH connector and rear lifting device LH connector.</p> <p>2. Check harness continuity between seat control unit LH connector and rear lifting device LH connector.</p>		
		SEL617WA
OK or NG		
OK	▶	GO TO 4.
NG	▶	Repair harness.

Terminals		Continuity
Seat control unit LH	Rear lifting device LH Lifting encoder (rear)	
17	4	Yes
28	6	
30	5	

4	CHECK LIFTING ENCODER (REAR) SHORT CIRCUIT	
<p>Check harness continuity between seat control unit LH connector and ground.</p>		
		SEL618W
OK or NG		
OK	▶	Replace lifting encoder (rear).
NG	▶	Repair harness.

Terminals	Continuity
17 - Ground	No
28 - Ground	
30 - Ground	

AUTOMATIC DRIVE POSITIONER

Trouble Diagnoses (Cont'd)

DIAGNOSTIC PROCEDURE 6 (Sliding motor check)

=NBEL0214S09

1	CHECK OUTPUT SIGNAL TO SLIDING MOTOR																
<p>Check voltage between seat control unit LH terminals 3 or 10 and ground.</p>																	
<p>Seat control unit LH (B513)</p>		<table border="1" style="width: 100%; border-collapse: collapse;"> <thead> <tr> <th rowspan="2">Condition of sliding switch</th> <th colspan="2">Terminals</th> <th rowspan="2">Voltage [V]</th> </tr> <tr> <th>+</th> <th>-</th> </tr> </thead> <tbody> <tr> <td>Forward</td> <td>3</td> <td>Ground</td> <td>Approx. 12</td> </tr> <tr> <td>Backward</td> <td>10</td> <td>Ground</td> <td>Approx. 12</td> </tr> </tbody> </table>		Condition of sliding switch	Terminals		Voltage [V]	+	-	Forward	3	Ground	Approx. 12	Backward	10	Ground	Approx. 12
Condition of sliding switch	Terminals		Voltage [V]														
	+	-															
Forward	3	Ground	Approx. 12														
Backward	10	Ground	Approx. 12														
SEL619W																	
OK or NG																	
OK	▶	GO TO 2.															
NG	▶	Replace seat control unit LH.															

2	CHECK SLIDING MOTOR													
<p>1. Disconnect sliding device LH connector. 2. Apply 12V DC direct current to motor and check operation.</p>														
<p>Sliding device LH (B518)</p>		<table border="1" style="width: 100%; border-collapse: collapse;"> <thead> <tr> <th colspan="2">Terminals</th> <th rowspan="2">Operation</th> </tr> <tr> <th>+</th> <th>-</th> </tr> </thead> <tbody> <tr> <td>2</td> <td>1</td> <td>Forward</td> </tr> <tr> <td>1</td> <td>2</td> <td>Backward</td> </tr> </tbody> </table>		Terminals		Operation	+	-	2	1	Forward	1	2	Backward
Terminals		Operation												
+	-													
2	1	Forward												
1	2	Backward												
SEL620WA														
OK or NG														
OK	▶	Check harness for operation between seat control unit LH and sliding motor.												
NG	▶	Replace sliding motor.												



GI
MA
EM
LC
EC
FE
AT
TF
PD
AX
SU
BR
ST
RS
BT
HA
SC
EL
IDX

AUTOMATIC DRIVE POSITIONER

Trouble Diagnoses (Cont'd)

DIAGNOSTIC PROCEDURE 7 (Reclining motor check)

=NBEL0214S10

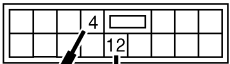
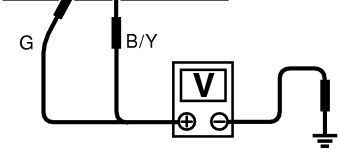
1	CHECK OUTPUT SIGNAL TO RECLINING MOTOR	<p>Check voltage between seat control unit LH terminals 4 or 12 and ground.</p> <div style="display: flex; justify-content: space-around; align-items: flex-start;"> <div style="text-align: center;">  <p>CONNECT</p>  </div> <div style="text-align: center;">  <p>Seat control unit LH (8513)</p> </div> </div>  <table border="1" style="margin-left: auto; margin-right: auto; border-collapse: collapse;"> <thead> <tr> <th rowspan="2">Condition of reclining switch</th> <th colspan="2">Terminals</th> <th rowspan="2">Voltage [V]</th> </tr> <tr> <th>+</th> <th>-</th> </tr> </thead> <tbody> <tr> <td>Forward</td> <td>4</td> <td>Ground</td> <td>Approx. 12</td> </tr> <tr> <td>Backward</td> <td>12</td> <td>Ground</td> <td>Approx. 12</td> </tr> </tbody> </table>			Condition of reclining switch	Terminals		Voltage [V]	+	-	Forward	4	Ground	Approx. 12	Backward	12	Ground	Approx. 12
Condition of reclining switch	Terminals		Voltage [V]															
	+	-																
Forward	4	Ground	Approx. 12															
Backward	12	Ground	Approx. 12															
OK or NG																		
OK	▶	GO TO 2.																
NG	▶	Replace seat control unit LH.																

SEL621W

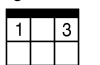
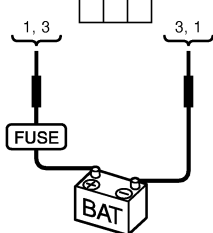
2	CHECK RECLINING MOTOR	<p>1. Disconnect reclining device LH connector. 2. Apply 12V DC direct current to motor and check operation.</p> <div style="display: flex; justify-content: space-around; align-items: flex-start;"> <div style="text-align: center;">  <p>DISCONNECT</p>  </div> <div style="text-align: center;"> <p>Reclining device LH (8515)</p>  </div> </div> <table border="1" style="margin-left: auto; margin-right: auto; border-collapse: collapse;"> <thead> <tr> <th colspan="2">Terminals</th> <th rowspan="2">Operation</th> </tr> <tr> <th>+</th> <th>-</th> </tr> </thead> <tbody> <tr> <td>1</td> <td>3</td> <td>Forward</td> </tr> <tr> <td>3</td> <td>1</td> <td>Backward</td> </tr> </tbody> </table>			Terminals		Operation	+	-	1	3	Forward	3	1	Backward
Terminals		Operation													
+	-														
1	3	Forward													
3	1	Backward													
OK or NG															
OK	▶	Check harness for operation between seat control unit LH and reclining motor.													
NG	▶	Replace reclining motor.													

SEL622WA

AUTOMATIC DRIVE POSITIONER

Trouble Diagnoses (Cont'd)

DIAGNOSTIC PROCEDURE 8

[Lifting motor (front) check]

=NBEL0214S11

1	CHECK OUTPUT SIGNAL TO LIFTING MOTOR (FRONT)																
<p>Check voltage between seat control unit LH terminals 5 or 13 and ground.</p>																	
<p>Seat control unit LH (BS13)</p>		<table border="1" style="width: 100%; border-collapse: collapse;"> <thead> <tr> <th rowspan="2">Condition of lifting switch (front)</th> <th colspan="2">Terminals</th> <th rowspan="2">Voltage [V]</th> </tr> <tr> <th>+</th> <th>-</th> </tr> </thead> <tbody> <tr> <td>Up</td> <td>13</td> <td>Ground</td> <td>Approx. 12</td> </tr> <tr> <td>Down</td> <td>5</td> <td>Ground</td> <td>Approx. 12</td> </tr> </tbody> </table>		Condition of lifting switch (front)	Terminals		Voltage [V]	+	-	Up	13	Ground	Approx. 12	Down	5	Ground	Approx. 12
Condition of lifting switch (front)	Terminals		Voltage [V]														
	+	-															
Up	13	Ground	Approx. 12														
Down	5	Ground	Approx. 12														
SEL623W																	
OK or NG																	
OK	▶	GO TO 2.															
NG	▶	Replace seat control unit LH.															

2	CHECK LIFTING MOTOR (FRONT)													
<p>1. Disconnect front lifting device LH connector. 2. Apply 12V DC direct current to motor and check operation.</p>														
<p>Front lifting device LH (BS18)</p>		<table border="1" style="width: 100%; border-collapse: collapse;"> <thead> <tr> <th colspan="2">Terminals</th> <th rowspan="2">Operation</th> </tr> <tr> <th>+</th> <th>-</th> </tr> </thead> <tbody> <tr> <td>3</td> <td>1</td> <td>Up</td> </tr> <tr> <td>1</td> <td>3</td> <td>Down</td> </tr> </tbody> </table>		Terminals		Operation	+	-	3	1	Up	1	3	Down
Terminals		Operation												
+	-													
3	1	Up												
1	3	Down												
SEL624WA														
OK or NG														
OK	▶	Check harness for operation between seat control unit LH and lifting motor (front).												
NG	▶	Replace lifting motor (front).												

GI
 MA
 EM
 LC
 EC
 FE
 AT
 TF
 PD
 AX
 SU
 BR
 ST
 RS
 BT
 HA
 SC
 EL
 IDX

AUTOMATIC DRIVE POSITIONER

Trouble Diagnoses (Cont'd)

DIAGNOSTIC PROCEDURE 9

[Lifting motor (rear) check]

=NBEL0214S12

1	CHECK OUTPUT SIGNAL TO LIFTING MOTOR (REAR)	
<p>Check voltage between seat control unit LH terminals 6 or 7 and ground.</p>		
SEL625W		
OK or NG		
OK	▶	GO TO 2.
NG	▶	Replace seat control unit LH.

2	CHECK LIFTING MOTOR (REAR)	
<p>1. Disconnect rear lifting device LH connector. 2. Apply 12V DC direct current to motor and check operation.</p>		
SEL626WA		
OK or NG		
OK	▶	Check harness for operation between seat control unit LH and lifting motor (rear).
NG	▶	Replace lifting motor (rear).

AUTOMATIC DRIVE POSITIONER

Trouble Diagnoses (Cont'd)

DIAGNOSTIC PROCEDURE 10 (Power seat switch check)

=NBEL0214S13

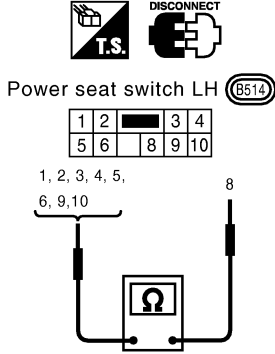
1	CHECK POWER SEAT SWITCH																																																																																																																																																			
<p>1. Disconnect power seat switch LH connector. 2. Check continuity between power seat switch terminals.</p>																																																																																																																																																				
																																																																																																																																																				
<table border="1" style="display: inline-table; border-collapse: collapse;"> <thead> <tr> <th rowspan="2">Switch</th> <th rowspan="2">Condition</th> <th colspan="10">Terminals</th> </tr> <tr> <th>8</th> <th>1</th> <th>2</th> <th>3</th> <th>4</th> <th>5</th> <th>6</th> <th>9</th> <th>10</th> </tr> </thead> <tbody> <tr> <td rowspan="2">Sliding</td> <td>Forward</td> <td>○</td> <td></td> <td></td> <td></td> <td></td> <td></td> <td></td> <td></td> <td></td> <td></td> <td></td> <td></td> <td></td> <td>○</td> </tr> <tr> <td>Backward</td> <td>○</td> <td></td> <td></td> <td></td> <td></td> <td>○</td> <td></td> <td></td> <td></td> <td></td> <td></td> <td></td> <td></td> <td></td> </tr> <tr> <td rowspan="2">Reclining</td> <td>Forward</td> <td>○</td> <td>○</td> <td></td> <td></td> <td></td> <td></td> <td></td> <td></td> <td></td> <td></td> <td></td> <td></td> <td></td> <td></td> </tr> <tr> <td>Backward</td> <td>○</td> <td></td> <td>○</td> <td></td> <td></td> <td></td> <td></td> <td></td> <td></td> <td></td> <td></td> <td></td> <td></td> <td></td> </tr> <tr> <td rowspan="2">Lifting (Front)</td> <td>Up</td> <td>○</td> <td></td> <td></td> <td></td> <td></td> <td></td> <td></td> <td></td> <td>○</td> <td></td> <td></td> <td></td> <td></td> <td></td> </tr> <tr> <td>Down</td> <td>○</td> <td></td> <td></td> <td></td> <td></td> <td></td> <td></td> <td></td> <td></td> <td></td> <td>○</td> <td></td> <td></td> <td></td> </tr> <tr> <td rowspan="2">Lifting (Rear)</td> <td>Up</td> <td>○</td> <td></td> <td></td> <td></td> <td></td> <td></td> <td></td> <td></td> <td></td> <td></td> <td></td> <td></td> <td>○</td> <td></td> </tr> <tr> <td>Down</td> <td>○</td> <td></td> <td></td> <td></td> <td>○</td> <td></td> <td></td> <td></td> <td></td> <td></td> <td></td> <td></td> <td></td> <td></td> </tr> </tbody> </table>				Switch	Condition	Terminals										8	1	2	3	4	5	6	9	10	Sliding	Forward	○													○	Backward	○					○									Reclining	Forward	○	○													Backward	○		○												Lifting (Front)	Up	○								○						Down	○										○				Lifting (Rear)	Up	○												○		Down	○				○									
Switch	Condition	Terminals																																																																																																																																																		
		8	1	2	3	4	5	6	9	10																																																																																																																																										
Sliding	Forward	○													○																																																																																																																																					
	Backward	○					○																																																																																																																																													
Reclining	Forward	○	○																																																																																																																																																	
	Backward	○		○																																																																																																																																																
Lifting (Front)	Up	○								○																																																																																																																																										
	Down	○										○																																																																																																																																								
Lifting (Rear)	Up	○												○																																																																																																																																						
	Down	○				○																																																																																																																																														
SEL569X																																																																																																																																																				
OK or NG																																																																																																																																																				
OK	▶	<p>Check the following.</p> <ul style="list-style-type: none"> ● Ground circuit for power seat switch ● Harness for open or short between seat control unit LH and power seat switch 																																																																																																																																																		
NG	▶	Replace power seat switch.																																																																																																																																																		

GI
MA
EM
LC
EC
FE
AT
TF
PD
AX
SU
BR
ST
RS
BT
HA
SC
EL
IDX

AUTOMATIC DRIVE POSITIONER

Trouble Diagnoses (Cont'd)

DIAGNOSTIC PROCEDURE 11 (Cancel switch check)

=NBEL0214S14

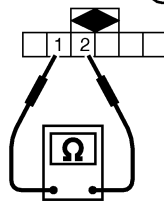
1	CHECK CANCEL SWITCH										
<p>1. Disconnect cancel switch connector. 2. Check continuity between cancel switch terminals.</p> <div style="display: flex; justify-content: space-around; align-items: flex-start;"> <div style="text-align: center;">  <p>Cancel switch (M17)</p>  </div> <div style="border: 1px solid black; padding: 5px;"> <table border="1" style="width: 100%; border-collapse: collapse; text-align: center;"> <thead> <tr> <th style="width: 25%;">Terminals</th> <th style="width: 25%;">Cancel switch condition</th> <th style="width: 50%;">Continuity</th> </tr> </thead> <tbody> <tr> <td rowspan="2">1-2</td> <td>ON</td> <td>Yes</td> </tr> <tr> <td>OFF</td> <td>No</td> </tr> </tbody> </table> </div> </div>				Terminals	Cancel switch condition	Continuity	1-2	ON	Yes	OFF	No
Terminals	Cancel switch condition	Continuity									
1-2	ON	Yes									
	OFF	No									
SEL628WA											
OK or NG											
OK	▶	<p>Check the following.</p> <ul style="list-style-type: none"> ● Ground circuit for cancel switch ● Harness for open or short between seat control unit LH and cancel switch 									
NG	▶	Replace cancel switch.									

AUTOMATIC DRIVE POSITIONER

Trouble Diagnoses (Cont'd)

DIAGNOSTIC PROCEDURE 12

(Key, detention, door switch and vehicle speed sensor check) =NBEL0214S15

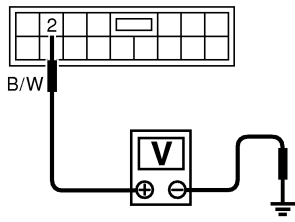
1	CHECK KEY SWITCH INPUT SIGNAL							
Check voltage between seat control unit LH terminal 2 and ground.								
<div style="display: flex; justify-content: space-between; align-items: flex-start;"> <div style="text-align: center;">  <p>Seat control unit LH (6513)</p>  </div> <table border="1" style="margin-left: auto; margin-right: auto;"> <thead> <tr> <th>Condition</th> <th>Voltage [V]</th> </tr> </thead> <tbody> <tr> <td>Key is inserted</td> <td>Approx. 12</td> </tr> <tr> <td>Key is removed</td> <td>0</td> </tr> </tbody> </table> </div>			Condition	Voltage [V]	Key is inserted	Approx. 12	Key is removed	0
Condition	Voltage [V]							
Key is inserted	Approx. 12							
Key is removed	0							
SEL629W								
OK or NG								
OK	▶	GO TO 2.						
NG	▶	Check the following. <ul style="list-style-type: none"> ● 7.5A fuse [No. 24, located in fuse block (J/B)] ● Key switch ● Harness for open or short between key switch and fuse ● Harness for open or short between seat control unit LH and key switch 						

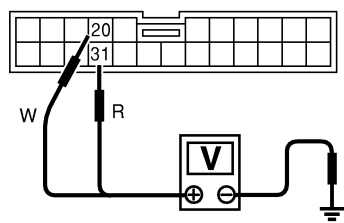
2	CHECK IGNITION SWITCH INPUT SIGNAL (ON AND START)																					
Check voltage between seat control unit LH terminals and ground.																						
<div style="display: flex; justify-content: space-between; align-items: flex-start;"> <div style="text-align: center;">  <p>Seat control unit LH (6512)</p>  </div> <table border="1" style="margin-left: auto; margin-right: auto;"> <thead> <tr> <th colspan="2">Terminals</th> <th colspan="3">Ignition switch position</th> </tr> <tr> <th>+</th> <th>-</th> <th>OFF</th> <th>ON</th> <th>START</th> </tr> </thead> <tbody> <tr> <td>20</td> <td>Ground</td> <td>Approx. 0V</td> <td colspan="2">Battery voltage</td> </tr> <tr> <td>31</td> <td>Ground</td> <td colspan="2">Approx. 0V</td> <td>Battery voltage</td> </tr> </tbody> </table> </div>			Terminals		Ignition switch position			+	-	OFF	ON	START	20	Ground	Approx. 0V	Battery voltage		31	Ground	Approx. 0V		Battery voltage
Terminals		Ignition switch position																				
+	-	OFF	ON	START																		
20	Ground	Approx. 0V	Battery voltage																			
31	Ground	Approx. 0V		Battery voltage																		
SEL630W																						
OK or NG																						
OK	▶	GO TO 3.																				
NG	▶	Check the following. <ul style="list-style-type: none"> ● 7.5A fuse [No. 11, located in fuse block (J/B)] ● 7.5A fuse [No. 26, located in fuse block (J/B)] ● Harness for open or short between seat control unit LH and fuse 																				

GI
MA
EM
LC
EC
FE
AT
TF
PD
AX
SU
BR
ST
RS
BT
HA
SC
EL
IDX

AUTOMATIC DRIVE POSITIONER

Trouble Diagnoses (Cont'd)

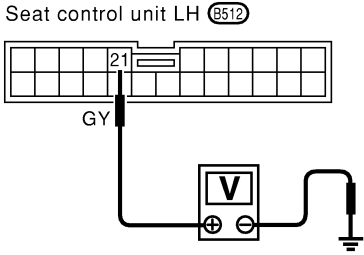
3	CHECK PARK POSITION SWITCH INPUT SIGNAL							
<p>Check voltage between seat control unit LH terminal 21 and ground.</p> <div style="display: flex; justify-content: space-between; align-items: flex-start;"> <div style="text-align: center;">  <p>Seat control unit LH (8512)</p>  </div> <table border="1" style="border-collapse: collapse;"> <thead> <tr> <th style="text-align: center;">Condition</th> <th style="text-align: center;">Voltage [V]</th> </tr> </thead> <tbody> <tr> <td style="text-align: center;">Selector lever is in "P" position</td> <td style="text-align: center;">0</td> </tr> <tr> <td style="text-align: center;">Except above</td> <td style="text-align: center;">Approx. 12</td> </tr> </tbody> </table> </div>			Condition	Voltage [V]	Selector lever is in "P" position	0	Except above	Approx. 12
Condition	Voltage [V]							
Selector lever is in "P" position	0							
Except above	Approx. 12							
SEL631W								
OK or NG								
OK	▶	GO TO 4.						
NG	▶	<p>Check the following.</p> <ul style="list-style-type: none"> ● Park position switch ● Park position switch ground circuit ● Harness for open or short between seat control unit LH and park position switch 						

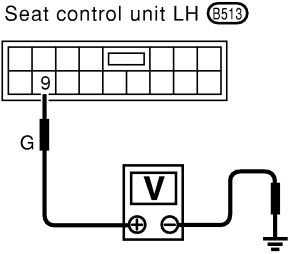
4	CHECK DRIVER DOOR SWITCH INPUT SIGNAL							
<p>Check voltage between seat control unit LH terminal 9 and ground.</p> <div style="display: flex; justify-content: space-between; align-items: flex-start;"> <div style="text-align: center;">  <p>Seat control unit LH (8513)</p>  </div> <table border="1" style="border-collapse: collapse;"> <thead> <tr> <th style="text-align: center;">Condition</th> <th style="text-align: center;">Voltage [V]</th> </tr> </thead> <tbody> <tr> <td style="text-align: center;">Driver's door is open</td> <td style="text-align: center;">0</td> </tr> <tr> <td style="text-align: center;">Driver's door is closed</td> <td style="text-align: center;">Approx. 12</td> </tr> </tbody> </table> </div>			Condition	Voltage [V]	Driver's door is open	0	Driver's door is closed	Approx. 12
Condition	Voltage [V]							
Driver's door is open	0							
Driver's door is closed	Approx. 12							
SEL632W								
OK or NG								
OK	▶	GO TO 5.						
NG	▶	<p>Check the following.</p> <ul style="list-style-type: none"> ● Driver door switch ● Driver door switch ground circuit ● Harness for open or short between seat control unit LH and driver door switch 						

5	CHECK VEHICLE SPEED SENSOR	
<p>Does speedometer operate normally?</p> <p style="text-align: center;">Yes or No</p>		
OK	▶	GO TO 6.
NG	▶	Check speedometer and vehicle speed sensor circuit. Refer to EL-104.

AUTOMATIC DRIVE POSITIONER

Trouble Diagnoses (Cont'd)

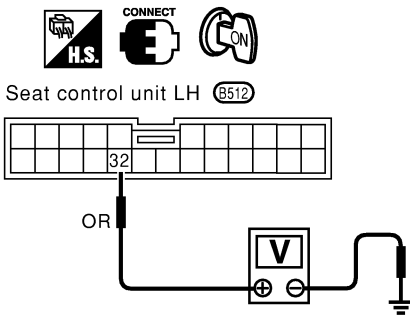
6	CHECK VEHICLE SPEED SENSOR PULL UP VOLTAGE	
<p>1. Turn ignition switch "ON". 2. Check voltage between seat control unit LH terminal 32 and ground.</p>		
<div style="display: flex; justify-content: space-between; align-items: center;"> <div style="text-align: center;">  <p>Seat control unit LH (B512)</p> <p>OR</p> <p>OK or NG</p> </div> <div style="text-align: right;"> <p>Approx. 5V should exist.</p> <p>SEL633W</p> </div> </div>		
OK	▶	Harness for open or short between seat control unit LH and combination meter.
NG	▶	Repair harness.

GI
 MA
 EM
 LC
 EC
 FE
 AT
 TF
 PD
 AX
 SU
 BR
 ST
 RS
 BT
 HA
 SC
EL
 IDX

AUTOMATIC DRIVE POSITIONER

Trouble Diagnoses (Cont'd)

DIAGNOSTIC PROCEDURE 13 (Seat memory switch check)

=NBEL0214S16

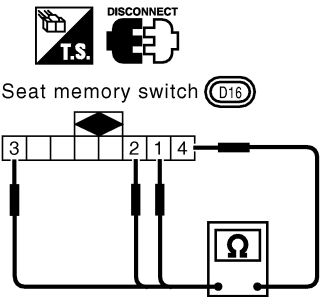
1	CHECK SEAT MEMORY SWITCH																													
<p>1. Disconnect seat memory switch connector. 2. Check continuity between seat memory switch terminals.</p>																														
																														
<table border="1" style="margin-left: auto; margin-right: 0;"> <thead> <tr> <th rowspan="2">Switch</th> <th rowspan="2">Condition</th> <th colspan="4">Terminals</th> </tr> <tr> <th>1</th> <th>2</th> <th>3</th> <th>4</th> </tr> </thead> <tbody> <tr> <td>Memory-1</td> <td>ON</td> <td style="text-align: center;">○</td> <td></td> <td></td> <td style="text-align: center;">○</td> </tr> <tr> <td>Memory-2</td> <td>ON</td> <td></td> <td style="text-align: center;">○</td> <td></td> <td style="text-align: center;">○</td> </tr> <tr> <td>Set</td> <td>ON</td> <td></td> <td></td> <td style="text-align: center;">○</td> <td style="text-align: center;">○</td> </tr> </tbody> </table>			Switch	Condition	Terminals				1	2	3	4	Memory-1	ON	○			○	Memory-2	ON		○		○	Set	ON			○	○
Switch	Condition	Terminals																												
		1	2	3	4																									
Memory-1	ON	○			○																									
Memory-2	ON		○		○																									
Set	ON			○	○																									
SEL634WA																														
OK or NG																														
OK	▶	<p>Check the following.</p> <ul style="list-style-type: none"> ● Ground circuit for seat memory switch ● Harness for open or short between seat control unit LH and seat memory switch 																												
NG	▶	Replace seat memory switch.																												

DIAGNOSTIC PROCEDURE 14 (Memory indicator check)

NBEL0214S17

1	CHECK INDICATOR LAMP	
Check indicator lamp illumination.		
OK or NG		
OK	▶	GO TO 2.
NG	▶	Replace seat memory switch (indicator lamp).

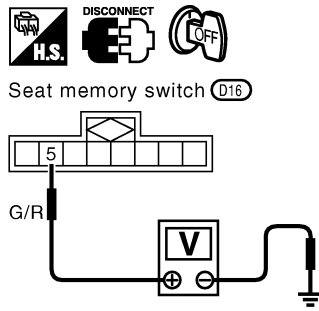
2	CHECK POWER SUPPLY CIRCUIT FOR INDICATOR LAMP	
<p>1. Disconnect seat memory switch connector. 2. Check voltage between seat memory switch terminal and ground.</p>		
		
Battery voltage should exist.		
SEL635WA		
OK or NG		
OK	▶	Check harness for open or short between seat control unit LH and seat memory switch
NG	▶	<p>Check the following.</p> <ul style="list-style-type: none"> ● 7.5A fuse [No. 24 located in the fuse block (J/B)] ● Harness for open or short between fuse and indicator lamp

AUTOMATIC SPEED CONTROL DEVICE (ASCD)

Component Parts and Harness Connector Location

Component Parts and Harness Connector Location

NBEL0094

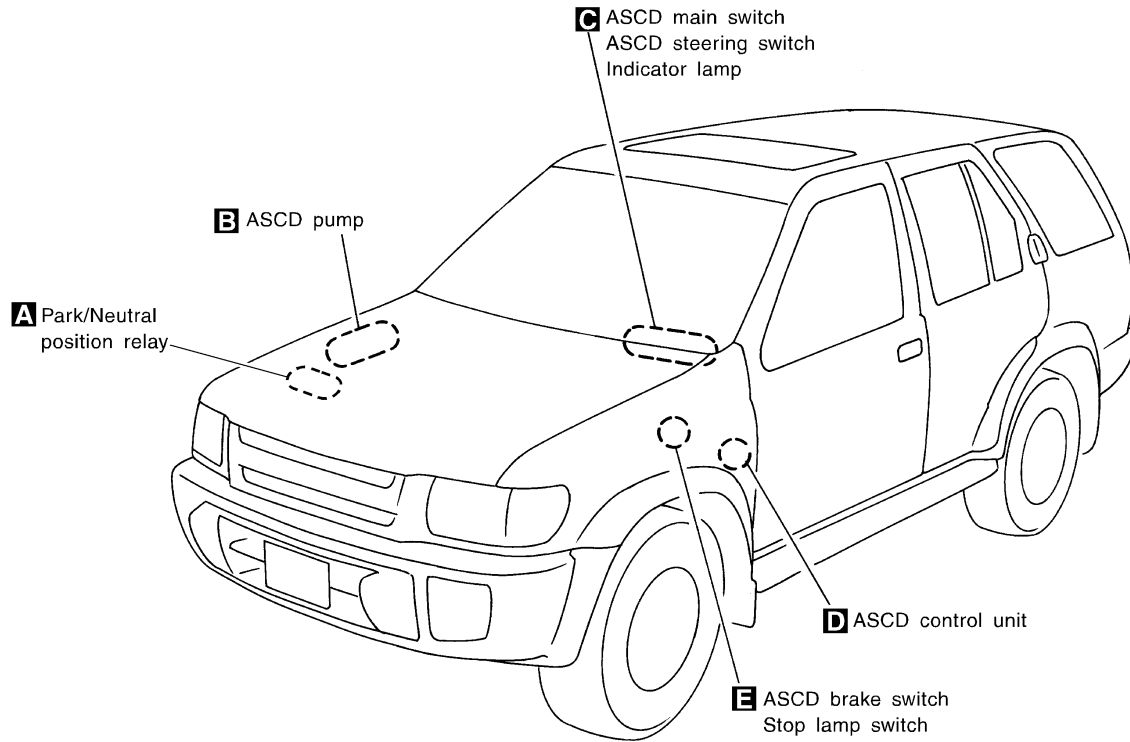

Fuse block (J/B)

1	2	3	4	5
6	7	8	9	10
11	12	13	14	15
16	17	18	19	20
21	22	23		
24	25	26		
27	28	29		

Front

Fuse and fusible link box

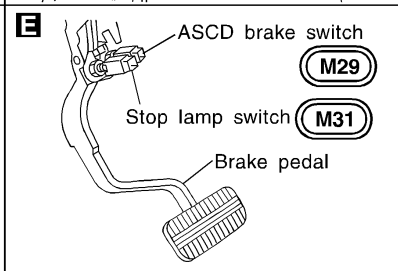
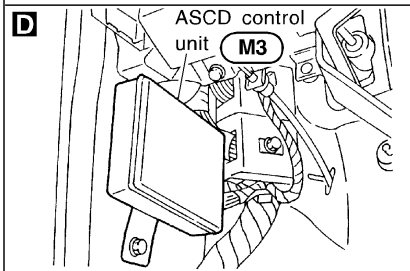
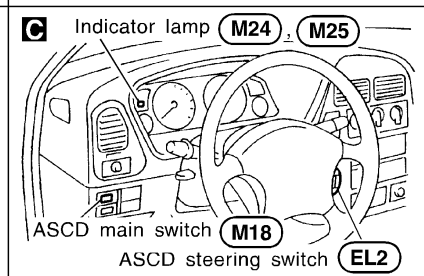
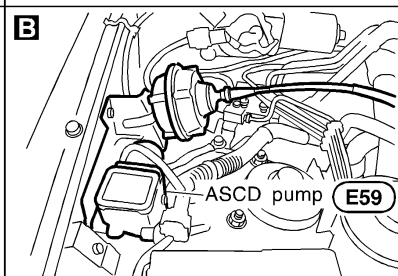
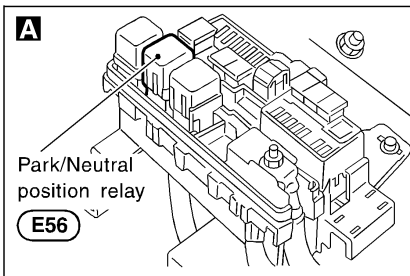
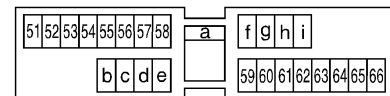

GI
MA
EM
LC
EC
FE
AT
TF
PD
AX
SU
BR
ST
RS
BT
HA
SC
EL
IDX

AUTOMATIC SPEED CONTROL DEVICE (ASCD)

System Description

System Description

NBEL0216

Refer to Owner's Manual for ASCD operating instructions.

POWER SUPPLY AND GROUND

NBEL0216S01

Power is supplied at all times:

- through 10A fuse [No. 14, located in the fuse block (J/B)]
- to the stop lamp switch terminal 1, and
- through 7.5A fuse (No. 52, located in fuse and fusible link box)
- to the horn relay terminals 1 and 3.

When ignition switch is in the ON or START position, power is supplied:

- through 7.5A fuse [No. 11, located in the fuse block (J/B)]
- to ASCD brake switch terminal 1 and
- to ASCD control unit terminal 5,
- through 10A fuse [No. 18, located in the fuse block (J/B)]
- to park/neutral position relay terminal 1,
- through 10A fuse [No. 8, located in the fuse block (J/B)]
- to combination meter terminal 66, and

When park/neutral position switch is in the P or N position, ground is supplied:

- to park/neutral position relay terminal 2
- through park/neutral position switch and body grounds B55 and B75.

When ASCD main switch is depressed (ON), ground is supplied:

- to ASCD control unit terminal 9
- from ASCD steering switch terminal 4
- to ASCD steering switch terminal 5
- through body grounds M4, M66 and M147

then ASCD control unit holds CRUISE condition and illuminates CRUISE indicator.

Ground is supplied:

- from ASCD control unit terminal 15
- to combination meter terminal 46.

OPERATION

NBEL0216S02

Set Operation

NBEL0216S0201

To activate the ASCD, all following conditions must exist.

- Ground supply to ASCD control unit terminal 9 (Main switch is in ON position.)
- Power supply to ASCD control unit terminal 8 (Brake pedal is released and A/T selector lever is in other than P and N position.)
- Vehicle speed is between 40 km/h (25 MPH) and 144 km/h (89 MPH). (Signal from combination meter)

When the SET/COAST switch is depressed, power is supplied:

- from ASCD steering switch terminal 2
- to ASCD control unit terminal 11.

And then ASCD pump is activated to control throttle wire and ASCD control unit supply ground

- to combination meter terminals 51 to illuminate SET indicator.

A/T Overdrive Control during Cruise Control Driving

NBEL0216S0202

When the vehicle speed is approximately 3 km/h (2 MPH) below set speed, a signal is sent

- from ASCD control unit terminal 10
- to TCM (transmission control module) terminal 24.

When this occurs, the TCM (transmission control module) cancels overdrive.

After vehicle speed is approximately 1 km/h (1 MPH) below set speed, overdrive is reactivated.

ASCD Shifting Control

NBEL0216S0203

During ASCD cruise, ASCD control unit controls A/T shifting to avoid uncomfortable shifting.

This is used to control the signals below.

- Throttle position sensor from ECM

AUTOMATIC SPEED CONTROL DEVICE (ASCD)

System Description (Cont'd)

- A/T shift solenoid valve A

Coast Operation

When the SET/COAST switch is depressed during cruise control driving, ASCD actuator returns the throttle cable to decrease vehicle set speed until the switch is released. And then ASCD will keep the new set speed.

NBEL0216S0204

Accel Operation

When the RESUME/ACCEL switch is depressed, power is supplied

NBEL0216S0205

- from ASCD steering switch terminal 3
- to ASCD control unit terminal 24.

If the RESUME/ACCEL switch is depressed during cruise control driving, ASCD actuator pulls the throttle cable to increase the vehicle speed until the switch is released or vehicle speed is reached to maximum controlled speed by the system. And then ASCD will keep the new set speed.

Cancel Operation

When any of following condition exists, cruise operation will be canceled.

NBEL0216S0206

- CANCEL switch is depressed. (Power supply to ASCD control unit terminals 11 and 24)
- Brake pedal is depressed. (Power supply to ASCD control unit terminal 23 from stop lamp switch)
- Brake pedal is depressed or A/T selector lever is shifted to P or N position. (Power supply to ASCD control unit terminal 8 is interrupted.)

If MAIN switch is turned to OFF during ASCD is activated, all of ASCD operation will be canceled and vehicle speed memory will be erased.

Resume Operation

When the RESUME/ACCEL switch is depressed after cancel operation other than depressing MAIN switch is performed, vehicle speed will return to last set speed. To resume vehicle set speed, vehicle condition must meet following conditions.

NBEL0216S0207

- Brake pedal is released.
- A/T selector lever is in other than P and N position.
- Vehicle speed is between 40 km/h (25 MPH) and 144 km/h (89 MPH).

ASCD PUMP OPERATION

The ASCD pump consists of a vacuum motor, an air valve and a release valve. When the ASCD activates, power is supplied

NBEL0216S03

- from terminal 12 of ASCD control unit
- to ASCD pump terminal 1.

Ground is supplied to vacuum motor, air valve and release valve from ASCD control unit depending on the operated condition as shown in the below table.

The pump is connected to ASCD actuator by vacuum hose. When the ASCD pump is activated, the ASCD pump vacuum the diaphragm of ASCD actuator to control throttle cable.

		Air valve (*1)	Release valve (*1)	Vacuum motor	Actuator inner pressure
ASCD not operating		Open	Open	Stopped	Atmosphere
ASCD operating	Releasing throttle cable	Open	Closed	Stopped	Vacuum
	Holding throttle position	Closed	Closed	Stopped	Vacuum (*2)
	Pulling throttle cable	Closed	Closed	Operated	Vacuum

*1: When power and ground is supplied, valve is closed.

*2: Set position held.

AUTOMATIC SPEED CONTROL DEVICE (ASCD)

Schematic

Schematic

NBEL0096

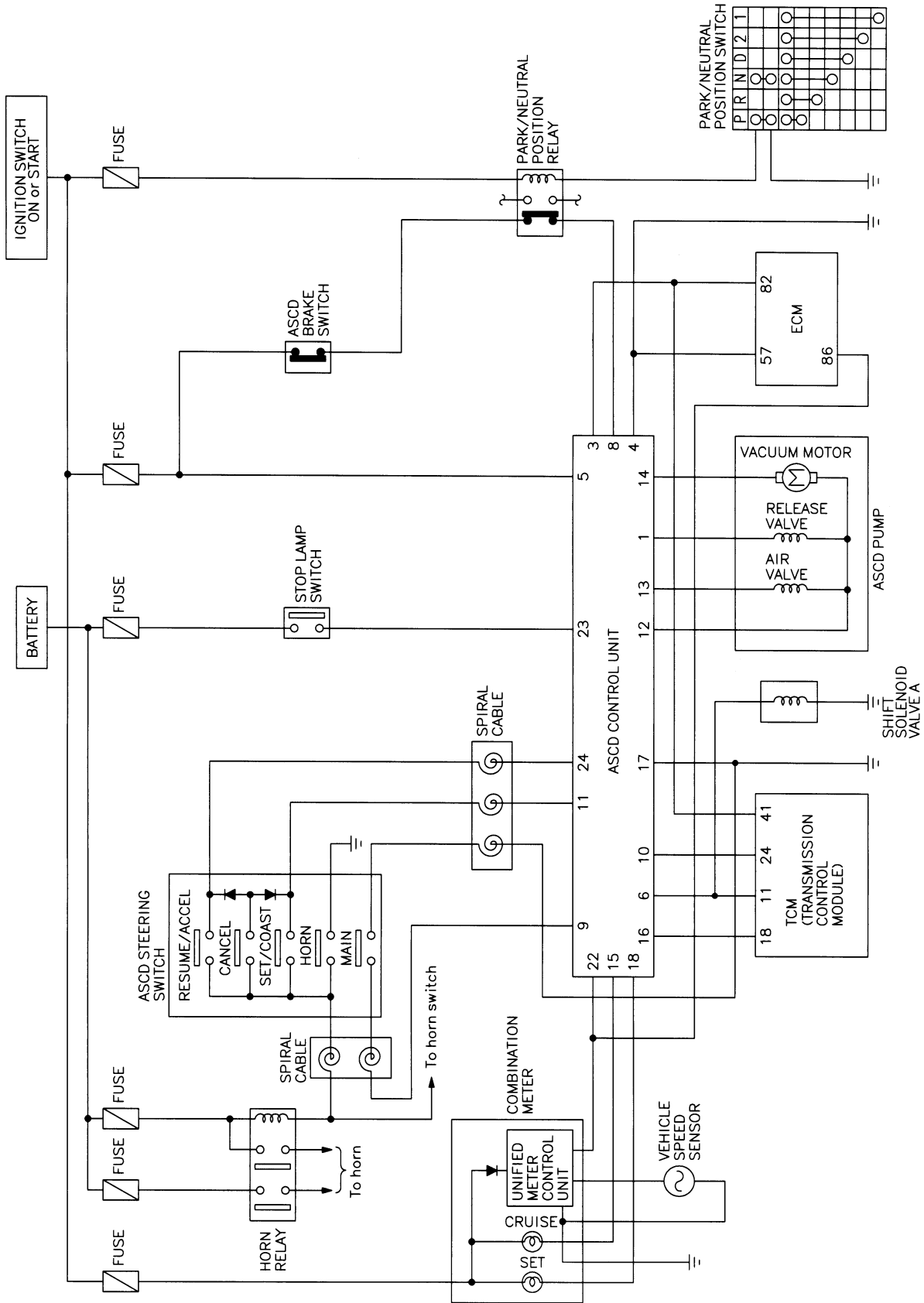

MEL837L

AUTOMATIC SPEED CONTROL DEVICE (ASCD)

Wiring Diagram — ASCD —

Wiring Diagram — ASCD —

NBEL0097

NBEL0097S01

FIG. 1

EL-ASCD-01

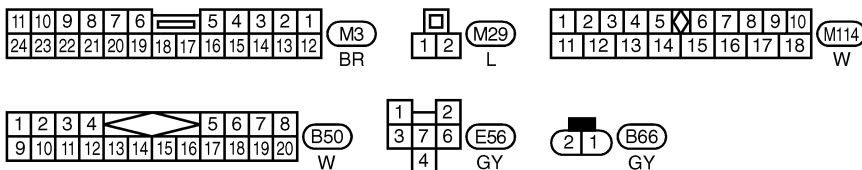
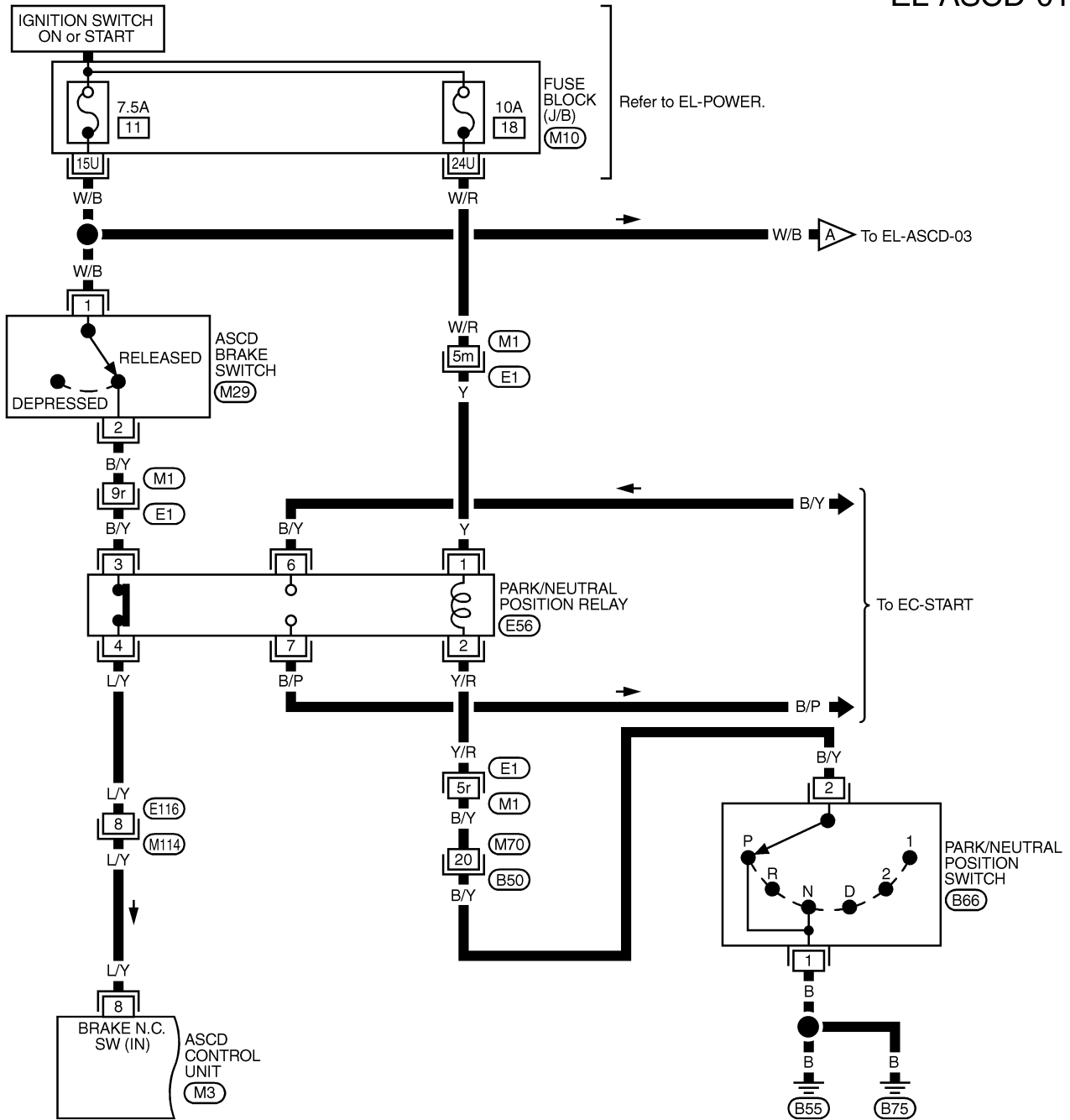

REFER TO THE FOLLOWING.

- (E1) -SUPER
- MULTIPLE JUNCTION (SMJ)
- (M10) -FUSE BLOCK-JUNCTION BOX (J/B)

GI
MA
EM
LC
EC
FE
AT
TF
PD
AX
SU
BR
ST
RS
BT
HA

SC
EL
IDX

AUTOMATIC SPEED CONTROL DEVICE (ASCD)

Wiring Diagram — ASCD — (Cont'd)

NBEL0097S02

FIG. 2

EL-ASCD-02

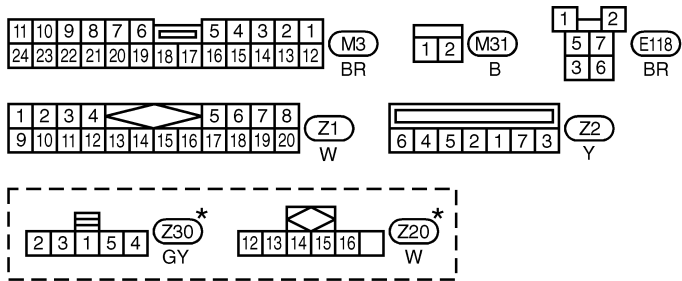
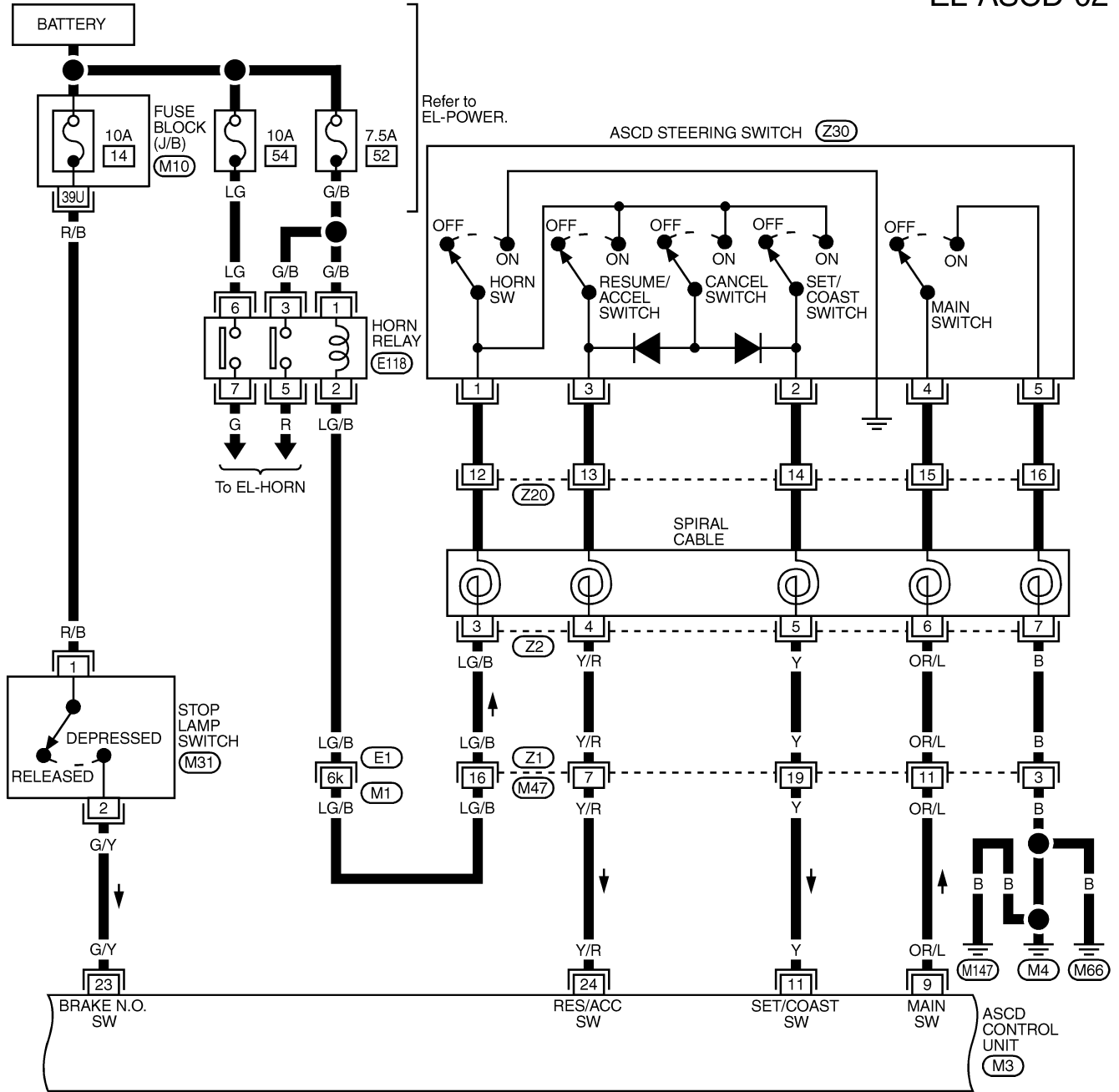

* : This connector is not shown in "HARNESS LAYOUT", EL section.

REFER TO THE FOLLOWING.

- (E1) -SUPER
- MULTIPLE JUNCTION (SMJ)
- (M10) -FUSE BLOCK-
- JUNCTION BOX (J/B)

MEL839L

AUTOMATIC SPEED CONTROL DEVICE (ASCD)

Wiring Diagram — ASCD — (Cont'd)

FIG. 3

NBEL0097S03

EL-ASCD-03

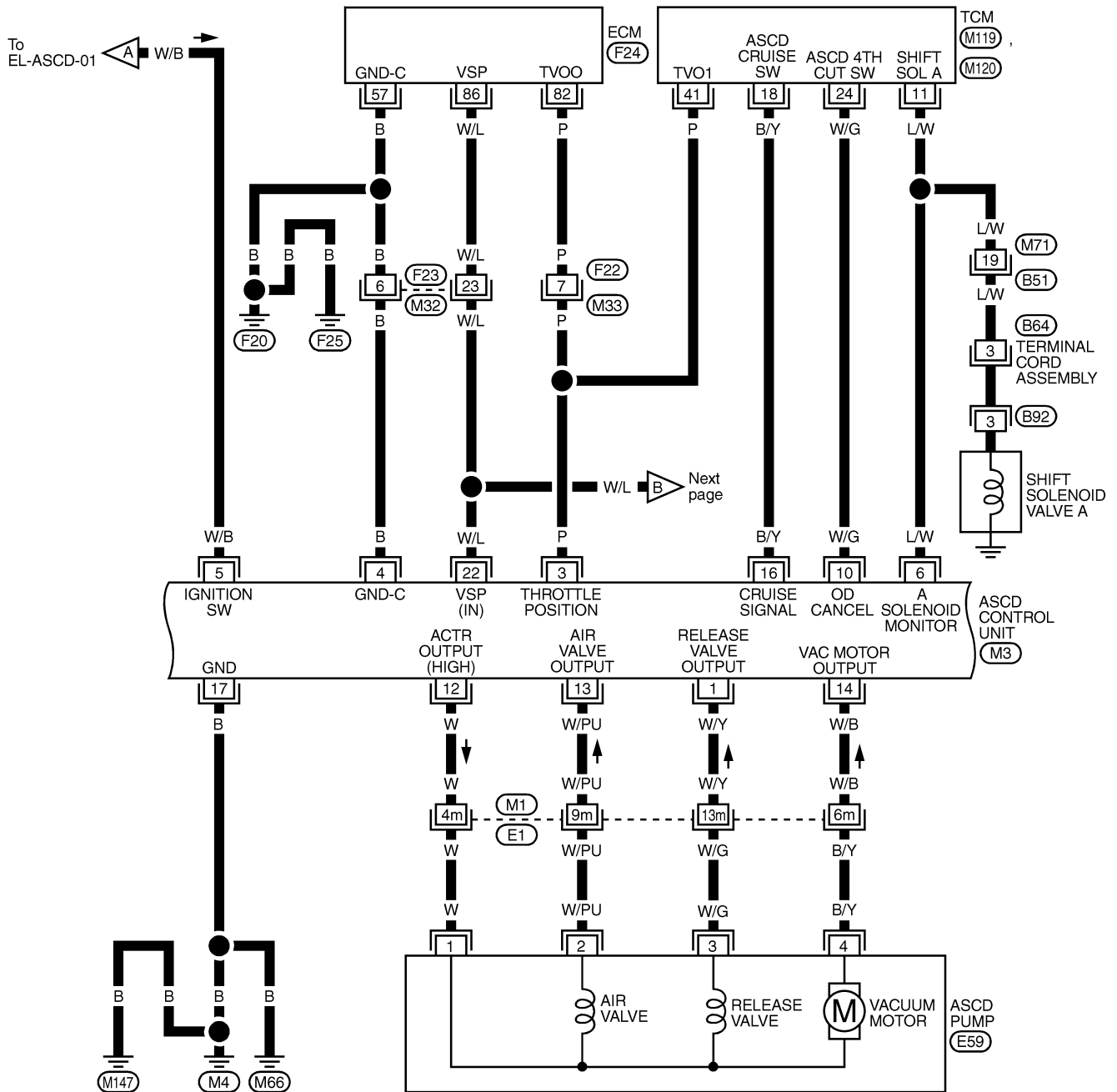

GI
MA
EM
LC
EC
FE
AT
TF
PD
AX
SU
BR
ST
RS
BT
HA
SC
EL
IDX

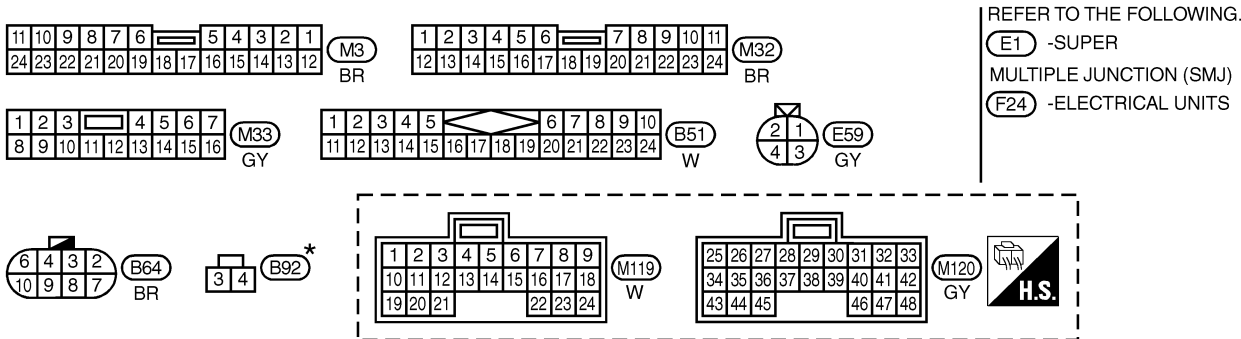

* : This connector is not shown in "HARNESS LAYOUT", EL section.

MEL840L

AUTOMATIC SPEED CONTROL DEVICE (ASCD)

Wiring Diagram — ASCD — (Cont'd)

NBEL0097S04

FIG. 4

EL-ASCD-04

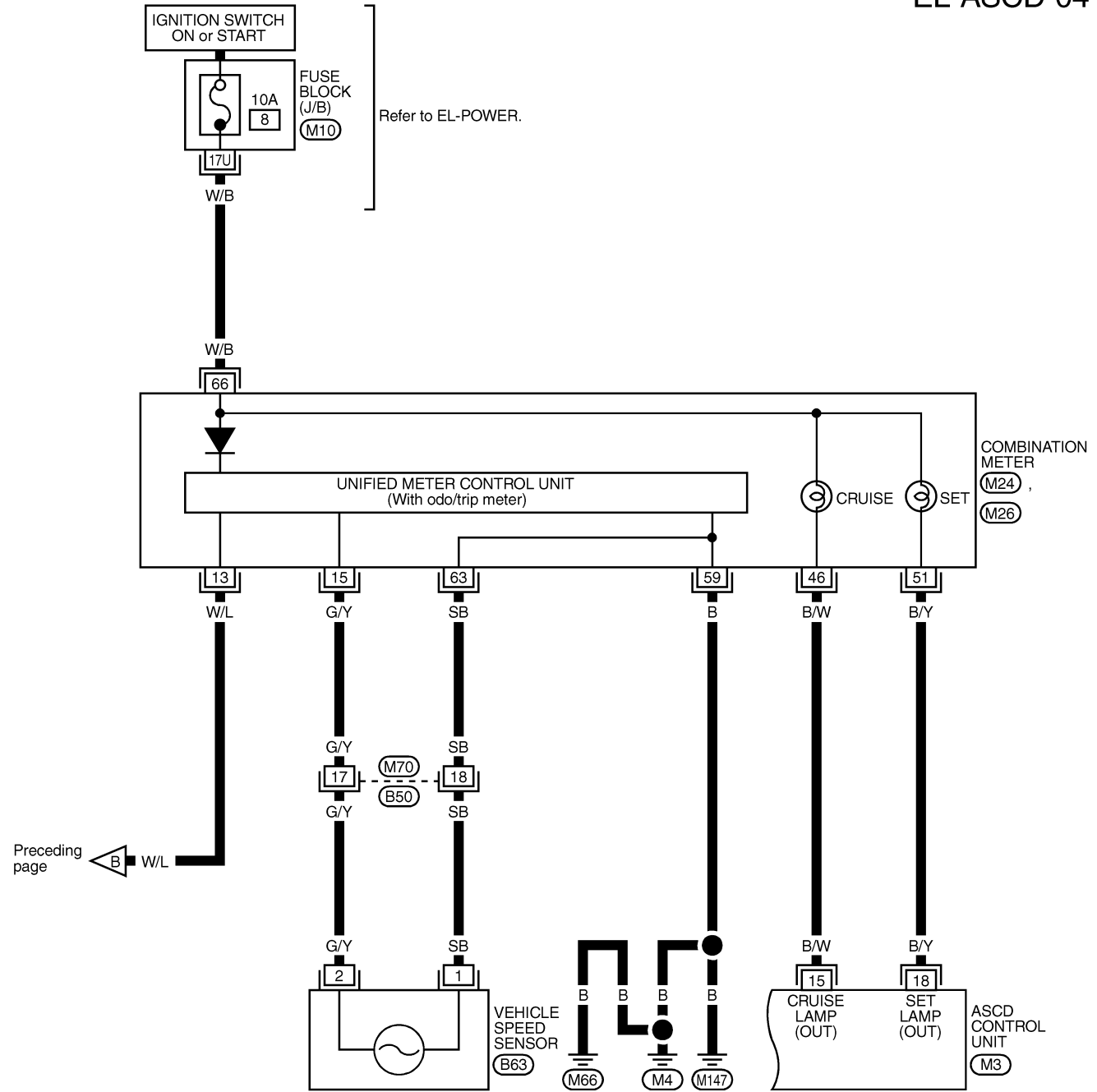

Preceding page ←

11	10	9	8	7	6	5	4	3	2	1		
24	23	22	21	20	19	18	17	16	15	14	13	12

(M3)
BR

1	2	3	4	5	6	7	8	9	10	11		
12	13	14	15	16	17	18	19	20	21	22	23	24

(M24)
W

45	46	47	48	49	50	51	52	53	54	55		
56	57	58	59	60	61	62	63	64	65	66	67	68

(M26)
BR

1	2	3	4	5	6	7	8				
9	10	11	12	13	14	15	16	17	18	19	20

(B50)
W

2	1
---	---

(B63)
GY

REFER TO THE FOLLOWING.

(M10) - FUSE BLOCK-
JUNCTION BOX (J/B)

MEL841L

AUTOMATIC SPEED CONTROL DEVICE (ASCD)

Fail-safe System

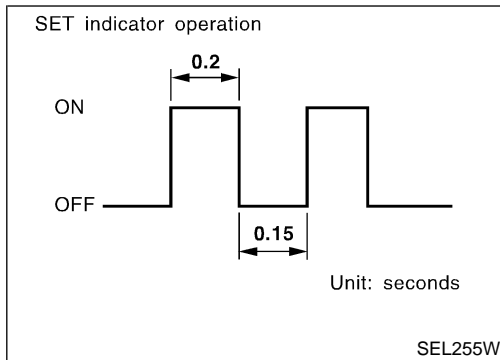

Fail-safe System

NBEL0217

DESCRIPTION

NBEL0217S01

When the fail-safe system senses a malfunction, it deactivates ASCD operation. The SET indicator in the combination meter will then flash.

GI

MA

EM

LC

MALFUNCTION DETECTION CONDITIONS

NBEL0217S02

Detection conditions	ASCD operation during malfunction detection
<ul style="list-style-type: none"> ● ASCD steering (RESUME/ACCEL, CANCEL, SET/COAST) switch is stuck. ● Vacuum motor ground circuit or power circuit is open or shorted. ● Air valve ground circuit or power circuit is open or shorted. ● Release valve ground circuit or power circuit is open or shorted. ● Vehicle speed sensor is faulty. ● ASCD control unit internal circuit is malfunctioning. 	<ul style="list-style-type: none"> ● ASCD is deactivated. ● Vehicle speed memory is canceled.
<ul style="list-style-type: none"> ● ASCD brake switch or stop lamp switch is faulty. 	<ul style="list-style-type: none"> ● ASCD is deactivated. ● Vehicle speed memory is not canceled.

EC

FE

AT

TF

PD

AX

SU

BR

ST

RS

BT

HA

SC

EL

IDX

AUTOMATIC SPEED CONTROL DEVICE (ASCD)

Trouble Diagnoses

Trouble Diagnoses SYMPTOM CHART

NBEL0218

NBEL0218S01

PROCEDURE	Diagnostic procedure						
REFERENCE PAGE (EL-)	231	232	233	234	235	235	237
SYMPTOM	FAIL-SAFE SYSTEM CHECK	POWER SUPPLY AND GROUND CIRCUIT CHECK	ASCD BRAKE/STOP LAMP SWITCH CHECK	ASCD STEERING SWITCH CHECK	VEHICLE SPEED SENSOR CHECK	ASCD PUMP CIRCUIT CHECK	ASCD ACTUATOR/PUMP CHECK
ASCD cannot be set. ("CRUISE" indicator lamp does not ON.)		X		X★3			
ASCD cannot be set. ("SET" indicator lamp does not blink.)			X	X	X		
ASCD cannot be set. ("SET" indicator lamp blinks.★1)	X		X	X	X	X	
Vehicle speed does not decrease after SET/COAST switch has been pressed.				X			X
Vehicle speed does not return to the set speed after RESUME/ACCEL switch has been pressed.★2				X			X
Vehicle speed does not increase after RESUME/ACCEL switch has been pressed.				X			X
System is not released after CANCEL switch (steering) has been pressed.				X			X
Large difference between set speed and actual vehicle speed.					X	X	X
Deceleration is greatest immediately after ASCD has been set.					X	X	X

★1: It indicates that system is in fail-safe. After completing diagnostic procedures, perform "FAIL-SAFE SYSTEM CHECK" (EL-231) to verify repairs.

★2: If vehicle speed is greater than 40 km/h (25 MPH) after system has been released, pressing RESUME/ACCEL switch returns vehicle speed to the set speed previously achieved. However, doing so when the ASCD main switch is turned to "OFF", vehicle speed will not return to the set speed since the memory is canceled.

★3: Check only main switch built-in steering switch.

AUTOMATIC SPEED CONTROL DEVICE (ASCD)

Trouble Diagnoses (Cont'd)

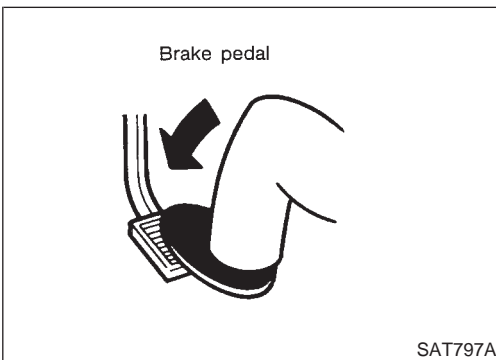
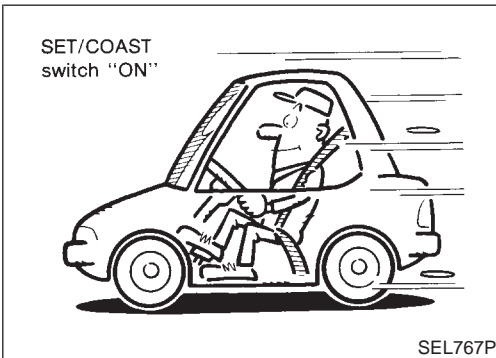
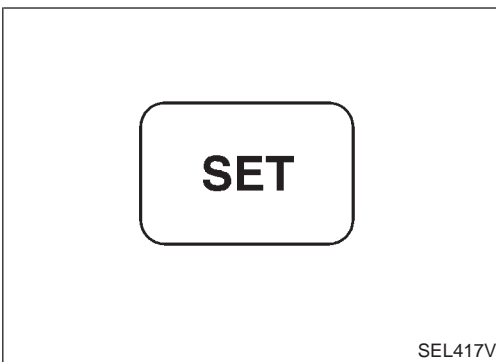

FAIL-SAFE SYSTEM CHECK

=NBEL0218S02

1. Turn ignition switch to ON position.
2. Turn ASCD main switch to ON and check if the SET indicator blinks.

If the indicator lamp blinks, check the following.

- ASCD steering switch. Refer to EL-234.

3. Drive the vehicle at more than 40 km/h (25 MPH) and push SET/COAST switch.

If the indicator lamp blinks, check the following.

- Vehicle speed sensor. Refer to EL-235.
- ASCD pump circuit. Refer to EL-235.
- Replace control unit.

4. Depress brake pedal slowly (brake pedal should be depressed more than 5 seconds).

If the indicator lamp blinks, check the following.

- ASCD brake/stop lamp switch. Refer to EL-233.

5. END. (System is OK.)

GI

MA

EM

LC

EC

FE

AT

TF

PD

AX

SU

BR

ST

RS

BT

HA

SC

EL

IDX

AUTOMATIC SPEED CONTROL DEVICE (ASCD)

Trouble Diagnoses (Cont'd)

POWER SUPPLY AND GROUND CIRCUIT CHECK

=NBEL0218S03

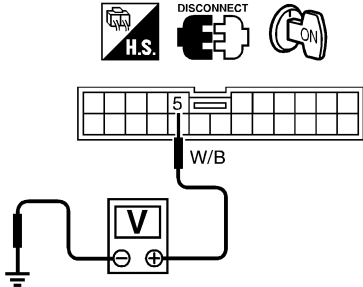
1	CHECK POWER SUPPLY CIRCUIT FOR ASCD CONTROL UNIT	
<p>1. Disconnect ASCD control unit harness connector. 2. Turn ignition switch ON. 3. Check voltage between ASCD control unit harness connector terminal 5 and ground.</p> <p style="text-align: center;">ASCD control unit connector (M3)</p>  <p style="text-align: right;">Does battery voltage exist?</p> <p style="text-align: right;">SEL256WB</p>		
Refer to wiring diagram in EL-227.		
Yes	▶	GO TO 2.
No	▶	<p>Check the following.</p> <ul style="list-style-type: none"> ● 7.5A fuse (No. 11 located in the fuse block) ● Harness for open or short

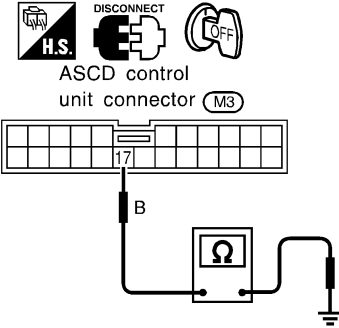

2	CHECK GROUND CIRCUIT FOR ASCD CONTROL UNIT	
<p>Check continuity between ASCD control unit harness connector terminal 17 and body ground.</p> <p style="text-align: center;">ASCD control unit connector (M3)</p>  <p style="text-align: right;">Does continuity exist?</p> <p style="text-align: right;">SEL257WB</p>		
Refer to wiring diagram in EL-227.		
Yes	▶	Power supply and ground circuit is OK.
No	▶	Repair harness.



AUTOMATIC SPEED CONTROL DEVICE (ASCD)

Trouble Diagnoses (Cont'd)

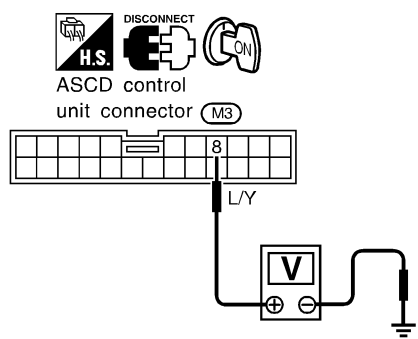
ASCD BRAKE/STOP LAMP SWITCH CHECK

=NBEL0218S04

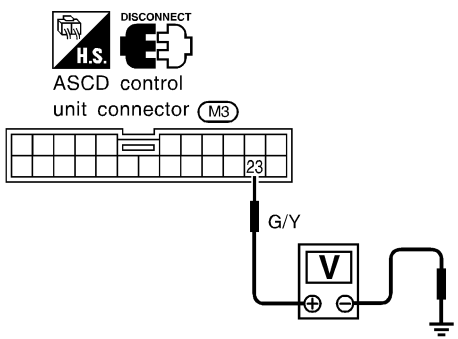
1	CHECK ASCD BRAKE SWITCH CIRCUIT	<p>1. Disconnect ASCD control unit harness connector. 2. Turn ignition switch ON. 3. Check voltage between ASCD control unit harness connector terminal 8 and ground.</p> <div style="display: flex; align-items: flex-start;"> <div style="flex: 1;">  <p>DISCONNECT H.S.   ASCD control unit connector (M3)</p> </div> <div style="flex: 2; padding-left: 20px;"> <p>When brake pedal is depressed or A/T selector lever is in "N" or "P" range: Approx. 0V</p> <p>When both brake pedal is released and A/T selector lever is not in "N" or "P" range: Battery voltage should exist.</p> </div> </div> <p style="text-align: right;">SEL258WD</p>	GI MA EM LC EC FE
OK or NG			
OK	▶	GO TO 2.	AT
NG	▶	<p>Check the following.</p> <ul style="list-style-type: none"> ● ASCD brake switch Refer to "Electrical Component Inspection" (EL-239). ● Park/neutral position switch Refer to "Electrical Component Inspection" (EL-239). ● Park/neutral position relay ● Harness for open or short 	TF PD

2	CHECK STOP LAMP SWITCH CIRCUIT	<p>1. Disconnect ASCD control unit harness connector. 2. Check voltage between ASCD control unit harness connector terminal 23 and ground.</p> <div style="display: flex; align-items: flex-start;"> <div style="flex: 1;">  <p>DISCONNECT H.S.   ASCD control unit connector (M3)</p> </div> <div style="flex: 2; padding-left: 20px;"> <p>Voltage [V]: Stop lamp switch: Depressed Approx. 12 Stop lamp switch: Released 0</p> </div> </div> <p>Refer to wiring diagram in EL-226.</p> <p style="text-align: right;">SEL259WB</p>	AX SU BR ST RS BT HA SC
OK or NG			
OK	▶	ASCD brake/stop lamp switch is OK.	BT
NG	▶	<p>Check the following.</p> <ul style="list-style-type: none"> ● 10A fuse [No. 14, located in the fuse block (J/B)] ● Harness for open or short between ASCD control unit and stop lamp switch ● Harness for open or short between fuse and stop lamp switch ● Stop lamp switch Refer to "Electrical Component Inspection" (EL-239). 	HA SC EL

IDX

AUTOMATIC SPEED CONTROL DEVICE (ASCD)

Trouble Diagnoses (Cont'd)

ASCD STEERING SWITCH CHECK

=NBEL0218S05

1 CHECK ASCD STEERING SWITCH CIRCUIT FOR ASCD CONTROL UNIT

Check voltage between ASCD control unit harness connector terminals and ground.

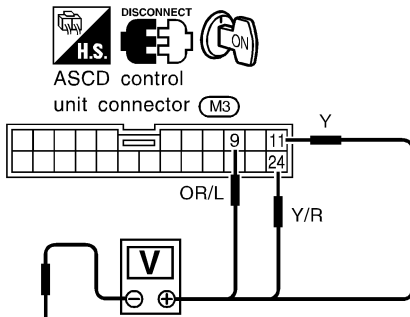

	Terminal No.		Switch condition	
	(+)	(-)	Pressed	Released
MAIN SW	9	Ground	0V	Approx. 9V
SET/COAST SW	11	Ground	12V	0V
RESUME/ACC SW	24	Ground	12V	0V
CANCEL SW	11	Ground	12V	0V
	24	Ground	12V	0V

Refer to wiring diagram in EL-226.

SEL260WC

OK or NG

OK	▶	ASCD steering switch is OK.
NG	▶	GO TO 2.

2 CHECK POWER SUPPLY FOR ASCD STEERING SWITCH

Does horn work?

Yes	▶	GO TO 3.
No	▶	Check the following. <ul style="list-style-type: none"> ● 7.5A fuse (No. 52, located in the relay box) ● Horn relay ● Horn circuit

3 CHECK ASCD STEERING SWITCH

1. Disconnect ASCD steering switch.
2. Check continuity between terminals by pushing each switch.

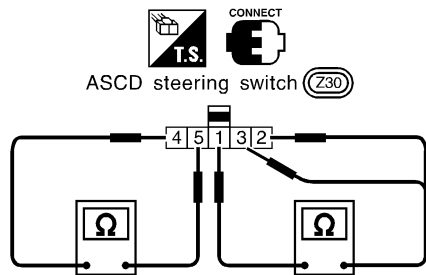

Switch	Condition	Terminal				
		1	2	3	4	5
MAIN	ON				○	○
RESUME/ACCEL	ON	○		○		
SET/COAST	ON	○	○			
CANCEL	ON	○	▶	○		
		○	▶	○		

SEL764WA

OK or NG

OK	▶	Check harness for open or short between ASCD steering switch and ASCD control unit.
NG	▶	Replace ASCD steering switch.

AUTOMATIC SPEED CONTROL DEVICE (ASCD)

Trouble Diagnoses (Cont'd)

VEHICLE SPEED SENSOR CHECK

=NBEL0218S06

1	CHECK SPEEDOMETER OPERATION	
Does speedometer operate normally?		
Yes	▶	GO TO 2.
No	▶	Check speedometer and vehicle speed sensor circuit. Refer to wiring diagram in EL-228.

GI
MA
EM

2	CHECK VEHICLE SPEED INPUT	
<p>1. Apply wheel chocks and jack up drive wheel. 2. Disconnect ASCD control unit harness connector. 3. Check voltage between control unit terminal 22 and ground with turning drive wheel slowly by hand.</p>		
Does voltage pointer deflect?		
SEL263WB		
Refer to wiring diagram in EL-227.		
Yes	▶	Vehicle speed sensor is OK.
No	▶	Check harness for open or short between ASCD control unit terminal 22 and combination meter terminal 13.

LC
EC
FE
AT
TF
PD
AX

ASCD PUMP CIRCUIT CHECK







NBEL0218S07

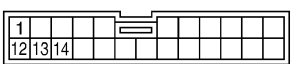

1	CHECK ASCD PUMP											
<p>1. Disconnect ASCD pump connector. 2. Measure resistance between ASCD pump terminals 1 and 2, 3, 4.</p>												
<table border="1" style="margin-left: auto;"> <thead> <tr> <th colspan="2">Terminals</th> <th>Resistance Ω</th> </tr> </thead> <tbody> <tr> <td rowspan="3" style="text-align: center;">1</td> <td style="text-align: center;">2</td> <td style="text-align: center;">Approx. 65</td> </tr> <tr> <td style="text-align: center;">3</td> <td style="text-align: center;">Approx. 65</td> </tr> <tr> <td style="text-align: center;">4</td> <td style="text-align: center;">Approx. 3</td> </tr> </tbody> </table>			Terminals		Resistance Ω	1	2	Approx. 65	3	Approx. 65	4	Approx. 3
Terminals		Resistance Ω										
1	2	Approx. 65										
	3	Approx. 65										
	4	Approx. 3										
SEL262WB												
Refer to wiring diagram in EL-227.												
OK or NG												
OK	▶	GO TO 2.										
NG	▶	Replace ASCD pump.										

SU
BR
ST
RS
BT
HA
SC
EL

AUTOMATIC SPEED CONTROL DEVICE (ASCD)

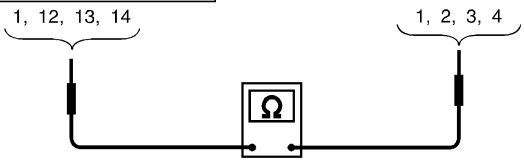
Trouble Diagnoses (Cont'd)

2	CHECK ASCD PUMP CIRCUIT																		
	<p>1. Disconnect ASCD control unit harness connector.</p> <p>2. Check harness for open or short between ASCD control unit and ASCD pump.</p>																		
	<div style="display: flex; justify-content: space-around; align-items: flex-start;"> <div style="text-align: center;">  <p>DISCONNECT H.S.</p> </div> <div style="text-align: center;">  <p>DISCONNECT E</p> </div> <div style="text-align: center;">  <p>OFF</p> </div> </div> <p>ASCD control unit connector (M3)</p>  <p>1, 12, 13, 14</p>																		
	<div style="text-align: center;">  <p>DISCONNECT T.S.</p> </div> <div style="text-align: center;">  <p>DISCONNECT E</p> </div>																		
	<p>ASCD pump connector (E59)</p>  <p>1, 2, 3, 4</p>																		
		<table border="1" style="width: 100%; border-collapse: collapse; text-align: center;"> <thead> <tr> <th rowspan="2">Circuit</th> <th colspan="2">Terminal</th> </tr> <tr> <th>ASCD control unit</th> <th>ASCD pump</th> </tr> </thead> <tbody> <tr> <td>ASCD pump power supply</td> <td>12</td> <td>1</td> </tr> <tr> <td>Air valve</td> <td>13</td> <td>2</td> </tr> <tr> <td>Release valve</td> <td>1</td> <td>3</td> </tr> <tr> <td>Vacuum motor</td> <td>14</td> <td>4</td> </tr> </tbody> </table> <p>Continuity should exist.</p>	Circuit	Terminal		ASCD control unit	ASCD pump	ASCD pump power supply	12	1	Air valve	13	2	Release valve	1	3	Vacuum motor	14	4
Circuit	Terminal																		
	ASCD control unit	ASCD pump																	
ASCD pump power supply	12	1																	
Air valve	13	2																	
Release valve	1	3																	
Vacuum motor	14	4																	
	OK or NG	SEL269WB																	
OK	▶	GO TO 3.																	
NG	▶	Repair harness.																	

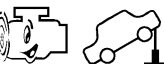
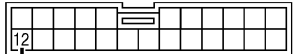
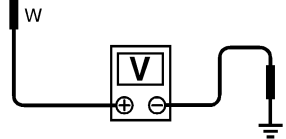
3	CHECK ASCD PUMP POWER SUPPLY	
	<p>1. Jack-up the drive wheels.</p> <p>2. Maintain the conditions below.</p> <ul style="list-style-type: none"> ● Vehicle speed is more than 40 km/h (25 MPH). ● Main switch (CRUISE lamp) is ON. ● Set/coast switch (SET lamp) is ON. <p>Check voltage between ASCD control unit harness connector terminal 12 and ground.</p>	
	<div style="text-align: center;">  <p>CONNECT H.S.</p> </div> <div style="text-align: center;">  <p>CONNECT E</p> </div> <div style="text-align: center;">  </div>	
	<p>ASCD control unit connector (M3)</p>  <p>12</p>	
		<p>Battery voltage should exist.</p>
	OK or NG	SEL381WB
OK	▶	ASCD pump power supply is OK.
NG	▶	Replace ASCD control unit.

AUTOMATIC SPEED CONTROL DEVICE (ASCD)

Trouble Diagnoses (Cont'd)

ASCD ACTUATOR/PUMP CHECK

=NBEL0218S08

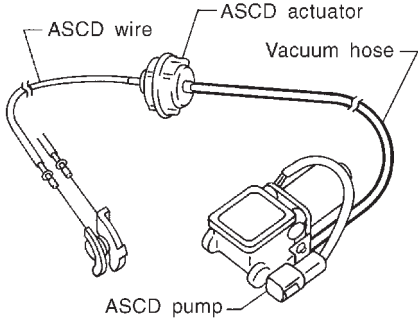
1	CHECK VACUUM HOSE	
<p>Check vacuum hose (between ASCD actuator and ASCD pump) for breakage, cracks or fracture.</p>		
		
MEL402G		
OK or NG		
OK	▶	GO TO 2.
NG	▶	Repair or replace hose.

2	CHECK ASCD WIRE	
<p>Check wire for improper installation, rust formation or breaks.</p>		
OK or NG		
OK	▶	GO TO 3.
NG	▶	Repair or replace wire. Refer to "ASCD Wire Adjustment" (EL-240).

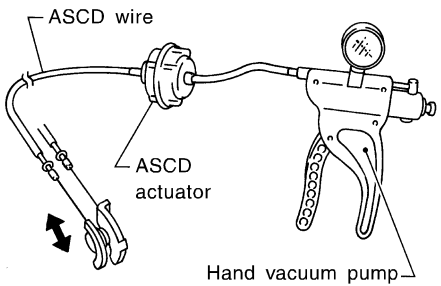
3	CHECK ASCD ACTUATOR	
<p>1. Disconnect vacuum hose from ASCD actuator. 2. Connect the hose of hand vacuum pump to ASCD actuator.</p>		
		
SEL264W		
OK or NG		
OK	▶	GO TO 4.
NG	▶	Replace ASCD actuator.

GI
MA
EM
LC
EC
FE
AT
TF
PD
AX
SU
BR
ST
RS
BT
HA
SC
EL
IDX

AUTOMATIC SPEED CONTROL DEVICE (ASCD)

Trouble Diagnoses (Cont'd)

4	CHECK ASCD PUMP																			
<ol style="list-style-type: none"> 1. Disconnect vacuum hose from ASCD pump and ASCD pump connector. 2. If necessary remove ASCD pump. 3. Connect vacuum gauge to ASCD pump. 4. Apply 12V direct current to ASCD pump and check operation. 																				
<table border="1" style="margin-left: auto; border-collapse: collapse;"> <thead> <tr> <th rowspan="2"></th> <th colspan="2">12V direct current supply terminals</th> <th rowspan="2">Operation</th> </tr> <tr> <th>(+)</th> <th>(-)</th> </tr> </thead> <tbody> <tr> <td>Air valve</td> <td rowspan="3" style="text-align: center;">1</td> <td style="text-align: center;">2</td> <td style="text-align: center;">Close</td> </tr> <tr> <td>Release valve</td> <td style="text-align: center;">3</td> <td style="text-align: center;">Close</td> </tr> <tr> <td>Vacuum motor</td> <td style="text-align: center;">4</td> <td style="text-align: center;">Operate</td> </tr> </tbody> </table> <p>A vacuum pressure of at least -40 kPa (-0.41 kg/cm², -5.8 psi) should be generated.</p>						12V direct current supply terminals		Operation	(+)	(-)	Air valve	1	2	Close	Release valve	3	Close	Vacuum motor	4	Operate
	12V direct current supply terminals		Operation																	
	(+)	(-)																		
Air valve	1	2	Close																	
Release valve		3	Close																	
Vacuum motor		4	Operate																	
SEL265WB																				
OK or NG																				
OK	▶	INSPECTION END																		
NG	▶	Replace ASCD pump.																		

AUTOMATIC SPEED CONTROL DEVICE (ASCD)

Electrical Component Inspection

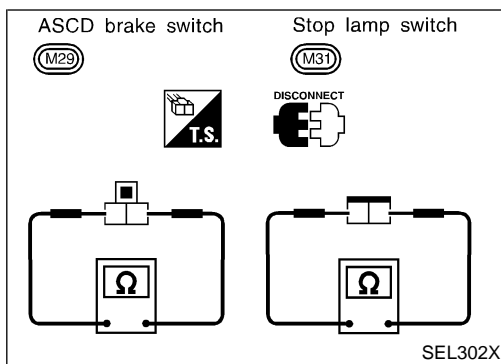

Electrical Component Inspection

ASCD BRAKE SWITCH AND STOP LAMP SWITCH

=NBEL0219

NBEL0219S02

Condition	Continuity	
	ASCD brake switch	Stop lamp switch
When brake pedal is depressed	No	Yes
When brake pedal is released	Yes	No

Check each switch after adjusting brake pedal — refer to BR-14, “BRAKE PEDAL AND BRACKET”.

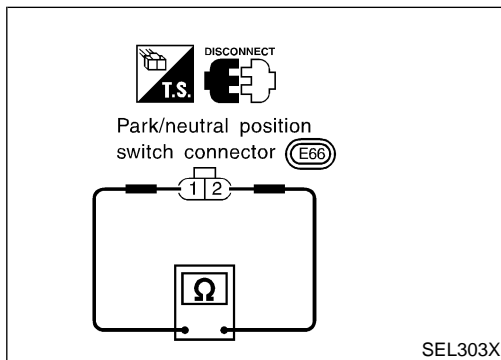

PARK/NEUTRAL POSITION SWITCH

NBEL0219S03

A/T selector lever position	Continuity	
	Between terminals 1 and 2	
“P”	Yes	
“N”	Yes	
Except “P” and “N”	No	

GI

MA

EM

LC

EC

FE

AT

TF

PD

AX

SU

BR

ST

RS

BT

HA

SC

EL

IDX

AUTOMATIC SPEED CONTROL DEVICE (ASCD)

ASCD Wire Adjustment

ASCD Wire Adjustment

=NBEL0220

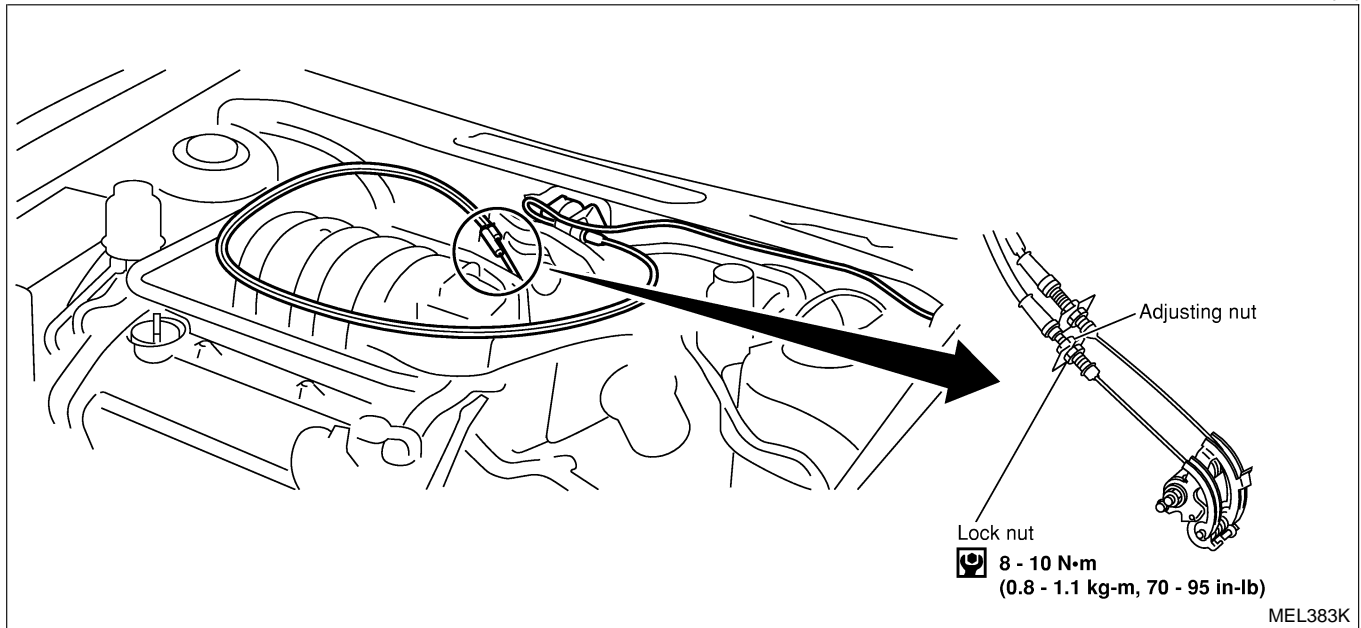

CAUTION:

- Be careful not to twist ASCD wire when removing it.
- Do not tense ASCD wire excessively during adjustment.

Adjust the tension of ASCD wire in the following manner.

1. Loosen lock nut and adjusting nut.
2. Make sure that accelerator wire is properly adjusted. Refer to FE-3, "ACCELERATOR CONTROL SYSTEM".
3. Tighten adjusting nut just until throttle drum starts to move.
4. Loosen adjusting nut again 1/2 to 1 turn.
5. Tighten lock nut.

System Description

NBEL0102

Power is supplied at all times

- from 40A fusible link (letter f, located in the fuse and fusible link box)
- to circuit breaker terminal 1
- through circuit breaker terminal 2
- to power window relay terminal 3,
- to front power window main switch terminal 4, and
- to front power window switch RH terminal 6.

GI

MA

EM

With ignition switch in ON or START position, power is supplied

- through 7.5A fuse [No. 11, located in the fuse block (J/B)]
- to power window relay terminal 2, and
- to smart entrance control unit terminal 33.

LC

EC

Ground is supplied to power window relay terminal 1

- through body grounds M4, M66 and M147.

FE

The power window relay is energized and power is supplied

- through power window relay terminal 5
- to front power window main switch terminal 11,
- to front power window switch RH terminal 13,
- to rear power window switch LH and RH terminals 5.

AT

TF

MANUAL OPERATION

Front Door LH

Ground is supplied

- to front power window main switch terminal 5
- through body grounds M77 and M111.

WINDOW UP

When the front LH switch in the front power window main switch is pressed in the up position, power is supplied

- to front power window regulator LH terminal 1
- through front power window main switch terminal 2.

Ground is supplied

- to front power window regulator LH terminal 3
- through front power window main switch terminal 3.

Then, the motor raises the window until the switch is released.

WINDOW DOWN

When the LH switch in the front power window main switch is pressed in the down position, power is supplied

- to front power window regulator LH terminal 3
- through front power window main switch terminal 3.

Ground is supplied

- to front power window regulator LH terminal 1
- through front power window main switch terminal 2.

Then, the motor lowers the window until the switch is released.

Front Door RH

Ground is supplied

- to front power window main switch terminal 5
- through body grounds M77 and M111.

NOTE:

Numbers in parentheses are terminal numbers, when power window switch is pressed in the UP and DOWN positions respectively.

FRONT POWER WINDOW MAIN SWITCH OPERATION

When front RH switch in the front power window main switch is pressed UP or DOWN, a signal is supplied

- through front power window main switch terminal 8

NBEL0102S01

NBEL0102S0101

PD

AX

SU

BR

ST

RS

BT

HA

SC

NBEL0102S0102

EL

IDX

POWER WINDOW

System Description (Cont'd)

- to front power window switch RH terminal 11.

The subsequent operation is the same as the front power window switch RH operation.

FRONT POWER WINDOW SWITCH RH OPERATION

Power is supplied

- through front power window switch RH (5, 4)
- to front power window regulator RH (1, 3).

Ground is supplied

- to front power window regulator RH (3, 1)
- through front power window switch RH (4, 5)
- to front power window switch RH terminal 12
- through front power window main switch terminal 1.

Then, the motor raises or lowers the window until the switch is released.

Rear Door LH

Ground is supplied

NBEL0102S0104

- to front power window main switch terminal 5
- through body grounds the M77 and M111.

NOTE:

Numbers in parentheses are terminal numbers, when the power window switch is pressed in the UP and DOWN positions.

FRONT POWER WINDOW MAIN SWITCH OPERATION

Power is supplied

- through front power window main switch terminal (13, 12)
- to rear power window switch LH terminal (3, 4)

The subsequent operation is the same as the rear power window switch LH operation.

REAR POWER WINDOW SWITCH LH

Power is supplied

- through rear power window switch LH (1, 2)
- to rear power window regulator LH (1, 2)

Ground is supplied

- to rear power window regulator LH (2, 1)
- through rear power window switch LH (2, 1)
- to rear power window switch LH terminal (4, 3)
- through front power window main switch terminal (12, 13)

Then, the motor raises or lowers the window until the switch is released.

Rear Door RH

Rear door RH windows will rise and lower in the same manner as the rear door LH window.

NBEL0102S0105

AUTO OPERATION

The power window AUTO feature enables the driver or front passenger to open or close the driver's and front passenger's window without holding the window switch in the up or down position.

The AUTO feature only operates on the driver's and front passenger's window upward and downward movement.

NBEL0102S02

POWER WINDOW LOCK

The power window lock is designed to lock operation of all windows except for driver's door window.

When the lock switch is pressed to lock position, the ground of the front and rear power window switches, in the power window main switch, is disconnected. This prevents the power window motors from operating.

NBEL0102S03

RETAINED POWER OPERATION

When the ignition switch is turned to OFF position from ON or START position, power is supplied for 45 seconds

- to power window relay terminal 2
- from smart entrance control unit terminal 5.

Ground is always supplied

NBEL0102S04

- to power window relay terminal 1
- through body grounds.

When power and ground are supplied, the power window relay continues to be energized, and the power window can be operated.

The retained power operation is canceled when the driver or passenger side door is opened.

INTERRUPTION DETECTION FUNCTION

Front power window main switch and front power window switch RH monitor the power window regulator motor operation and the power window position (full closed or other) for driver's and passenger's power window by the signals from encoder and limit switch in front power window regulator LH or RH.

When front power window main switch or front power window switch RH detects interruption during the following close operation in the driver's or front passenger's side door,

- automatic close operation when ignition switch is in the "ON" position
- automatic close operation during retained power operation

front power window main switch or front power window switch RH controls driver's or front passenger's power window regulator motor for open and the power window will be lowered about 150 mm (5.91 in).

GI

MA

EM

LC

EC

FE

AT

TF

PD

AX

SU

BR

ST

RS

BT

HA

SC

EL

IDX

POWER WINDOW

Schematic

Schematic

NBEL0103

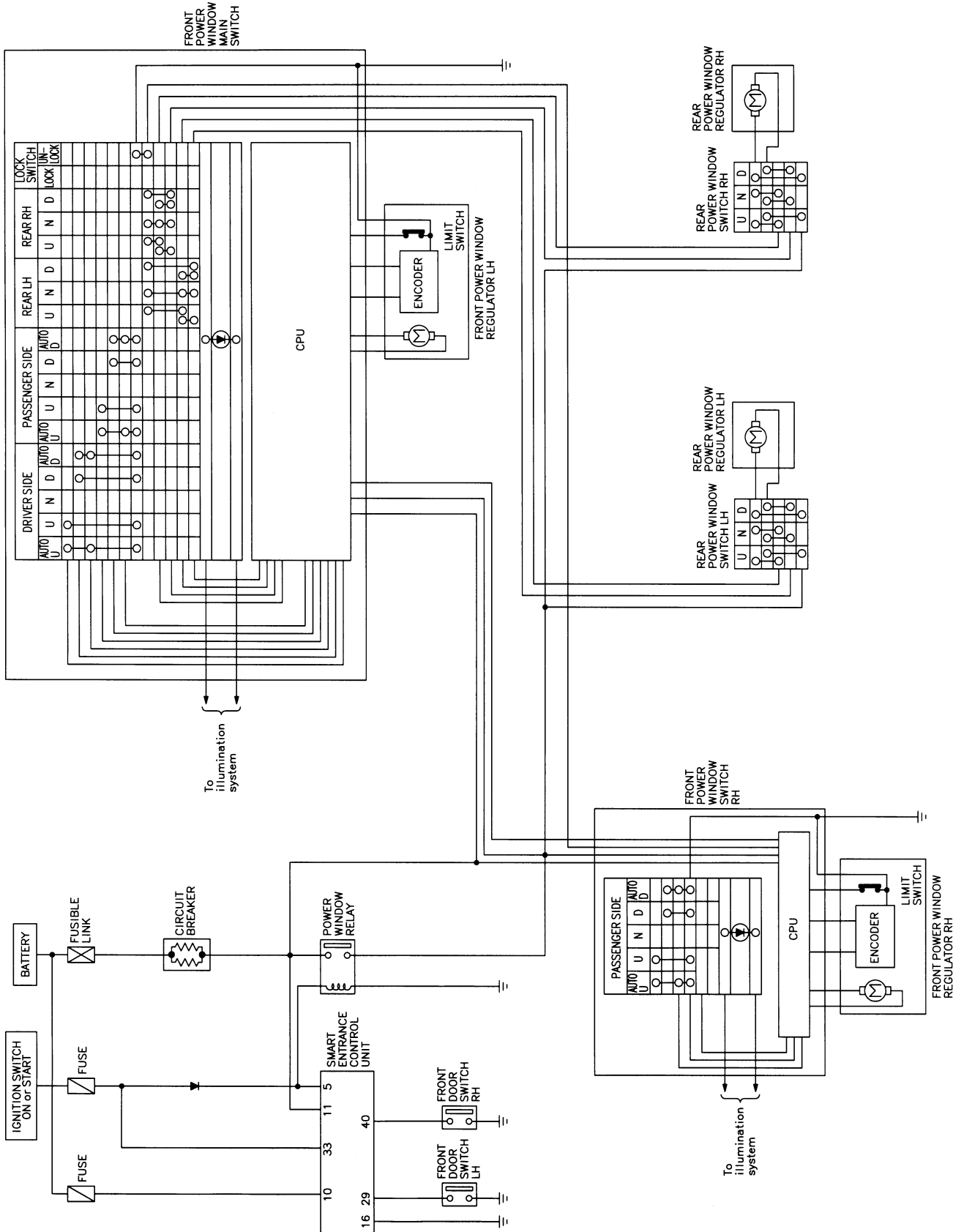

MEL842L

POWER WINDOW

Wiring Diagram — WINDOW —

Wiring Diagram — WINDOW —

NBEL0104

EL-WINDOW-01

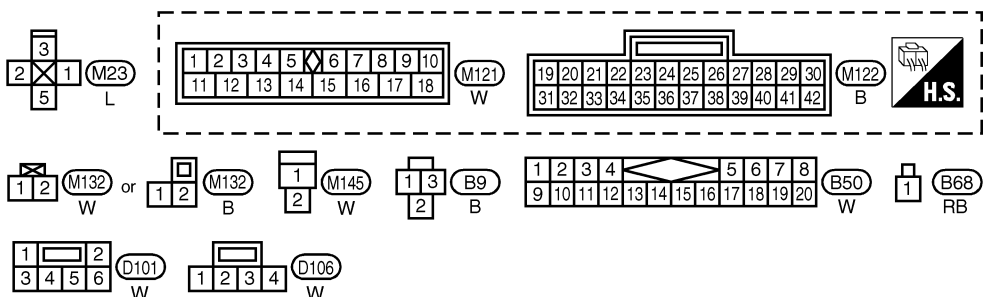
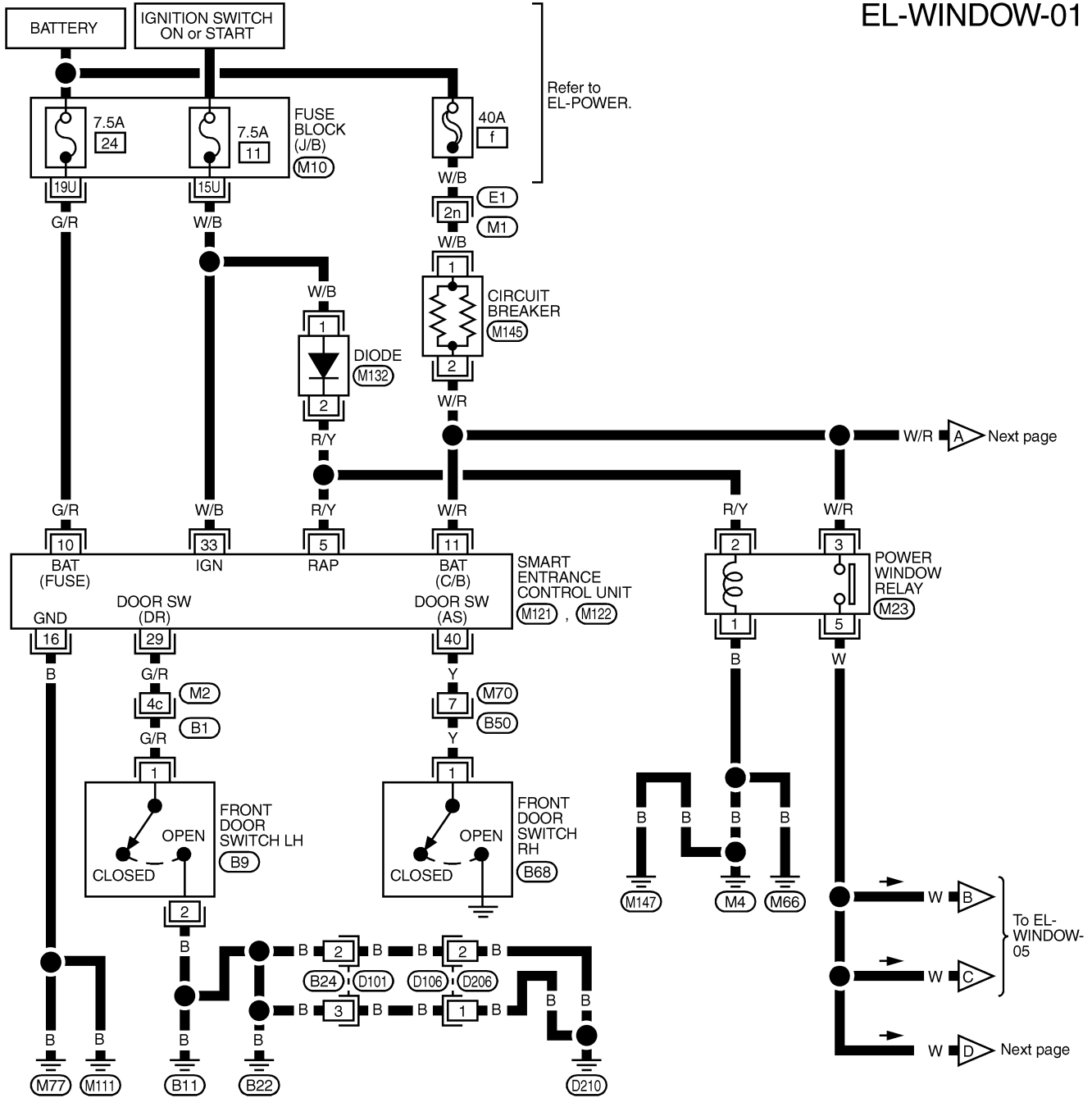

REFER TO THE FOLLOWING.
 (E1), (B1) -SUPER MULTIPLE
 JUNCTION (SMJ)
 (M10) -FUSE BLOCK -
 JUNCTION BOX (J/B)

GI
MA
EM
LC
EC
FE
AT
TF
PD
AX
SU
BR
ST
RS
BT
HA
SC
EL
IDX

POWER WINDOW

Wiring Diagram — WINDOW — (Cont'd)

EL-WINDOW-02

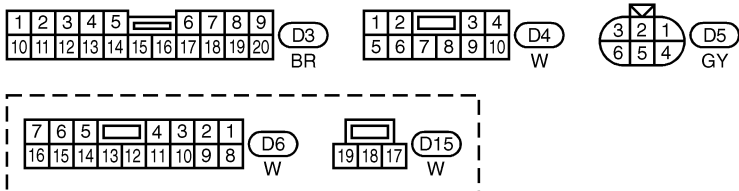
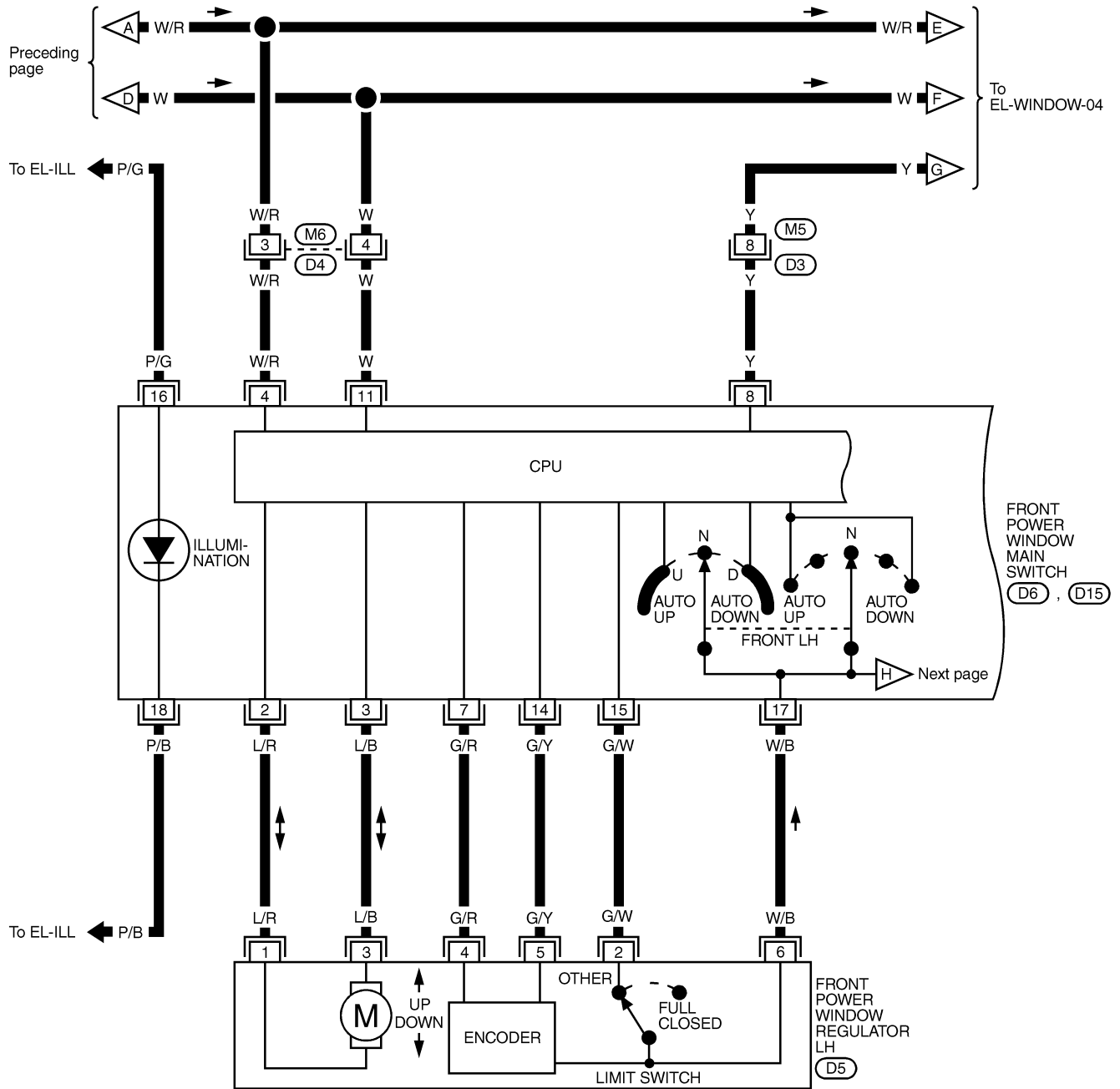

MEL844L

POWER WINDOW

Wiring Diagram — WINDOW — (Cont'd)

EL-WINDOW-03

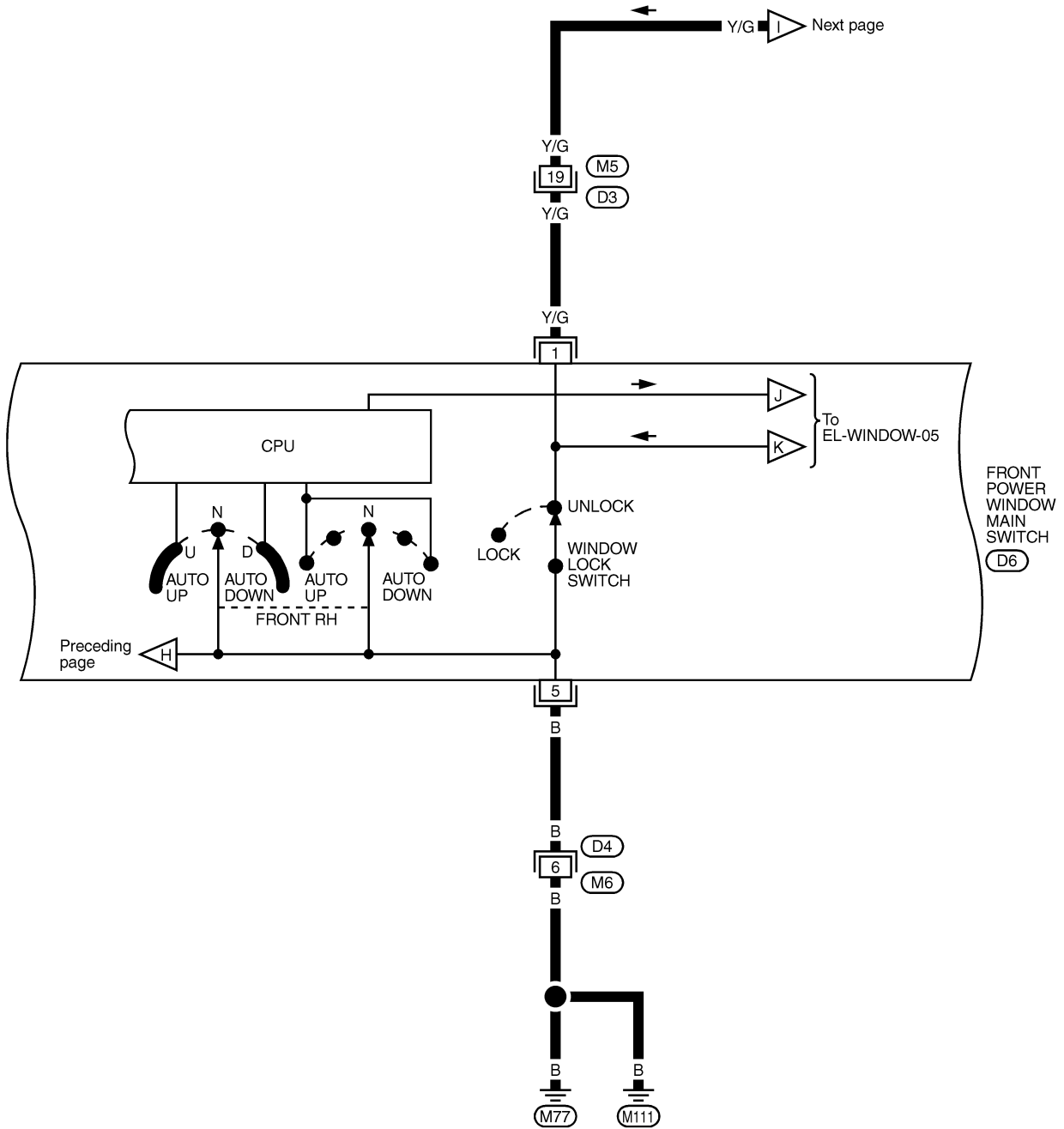

GI
MA
EM
LC
EC
FE
AT
TF
PD
AX
SU
BR
ST
RS
BT
HA
SC
EL
IDX

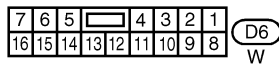
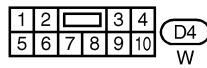
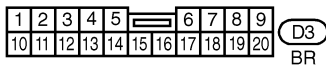

POWER WINDOW

Wiring Diagram — WINDOW — (Cont'd)

EL-WINDOW-04

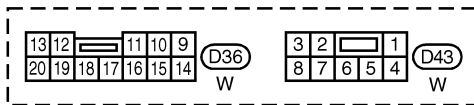
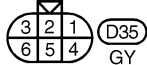
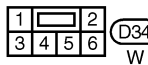
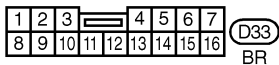
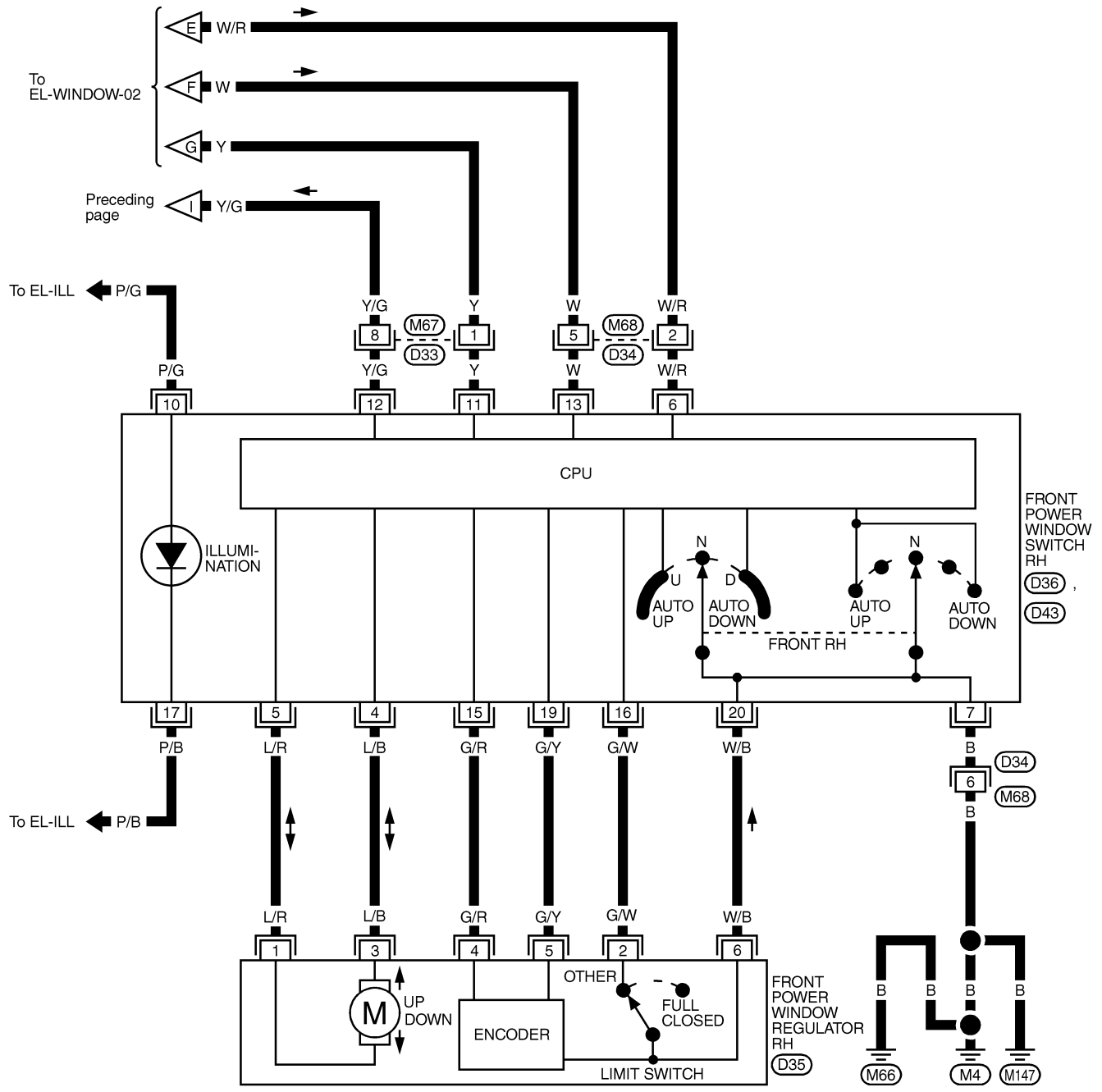

MEL846L

POWER WINDOW

Wiring Diagram — WINDOW — (Cont'd)

EL-WINDOW-05

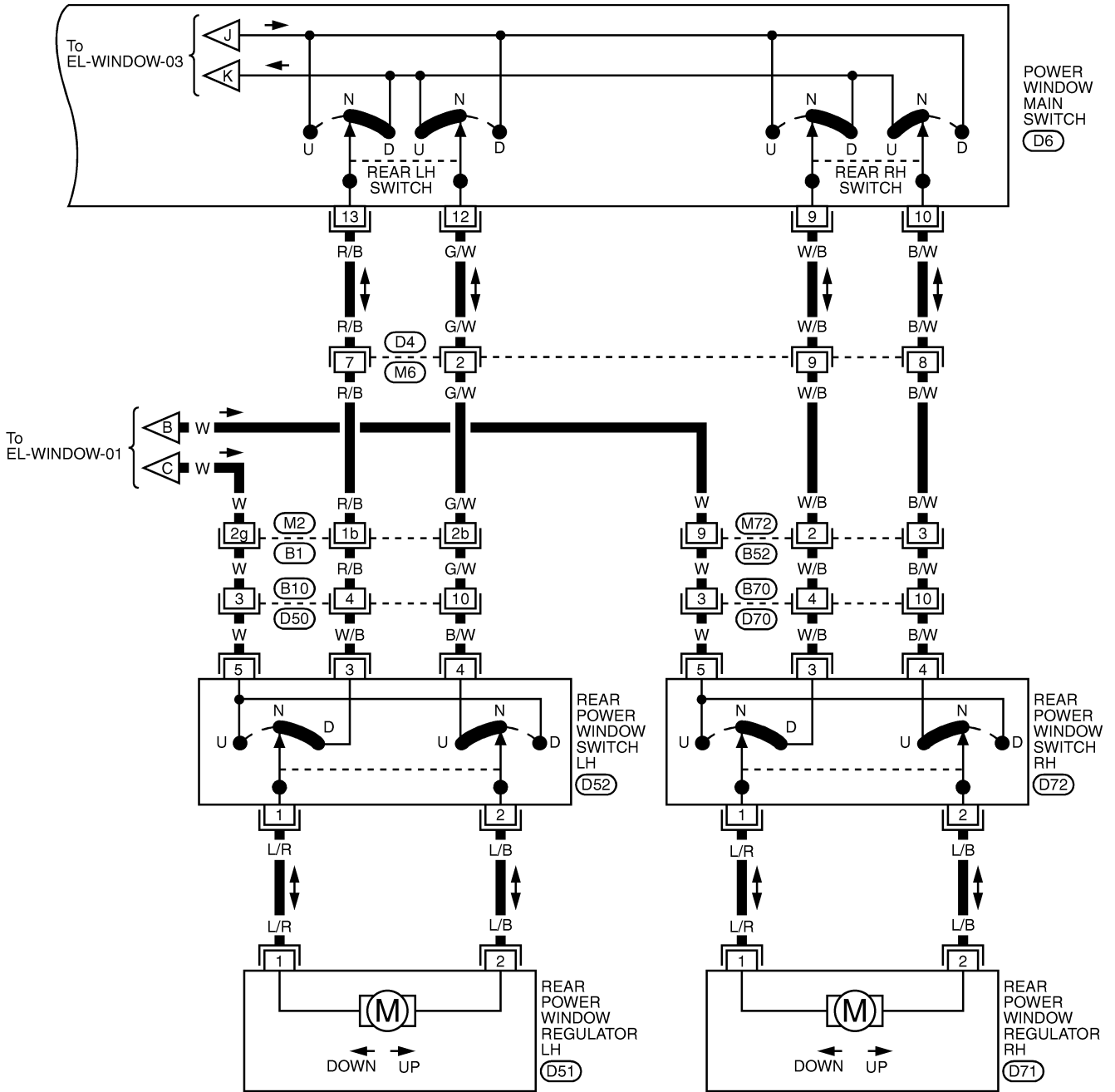

1	2	3	4	5	6	7		
8	9	10	11	12	13	14	15	16

(B52) W

1	2	3	4		
5	6	7	8	9	10

(D4) W, (D50) W, (D70) W

7	6	5	4	3	2	1		
16	15	14	13	12	11	10	9	8

(D6) W

2	1
---	---

(D51) B, (D71) B

4	1	3	2	5
---	---	---	---	---

(D52) W, (D72) W

REFER TO THE FOLLOWING.

(B1) -SUPER
MULTIPLE JUNCTION (SMJ)

GI
MA
EM
LC
EC
FE
AT
TF
PD
AX
SU
BR
ST
RS
BT
HA
SC
EL
IDX

MEL847L

POWER WINDOW

Trouble Diagnoses

Trouble Diagnoses

NBEL0221

Symptom	Possible cause	Repair order
None of the power windows can be operated using any switch.	<ol style="list-style-type: none"> 1. 7.5A fuse, 40A fusible link 2. M145 circuit breaker 3. Power window relay 4. M145 circuit breaker circuit 5. Power window relay circuit 6. Ground circuit 7. Power window main switch 	<ol style="list-style-type: none"> 1. Check 7.5A fuse [No. 11, located in fuse block (J/B)], 40A fusible link (letter f, located in fuse and fusible link box). 2. Check M145 circuit breaker. 3. Check power window relay. 4. Check the following. <ol style="list-style-type: none"> a. Harness between M145 circuit breaker and 40A fusible link b. Harness between M145 circuit breaker and front power window main switch 5. Check the following. <ol style="list-style-type: none"> a. Harness between 7.5A fuse and power window relay b. Harness between M145 circuit breaker and power window relay 6. Check the following. <ol style="list-style-type: none"> a. Ground circuit of power window main switch terminal 5 b. Power window relay ground circuit 7. Check power window main switch.
Driver side power window cannot be operated but other windows can be operated.	<ol style="list-style-type: none"> 1. Driver side power window regulator circuit 2. Driver side power window regulator 3. Power window main switch 	<ol style="list-style-type: none"> 1. Check harness between power window main switch and driver side power window regulator for open or short circuit. 2. Check driver side power window regulator. 3. Check power window main switch.
Passenger side power window cannot be operated but other window can be operated.	<ol style="list-style-type: none"> 1. Power supply for front power window switch RH 2. Front power window switch RH ground circuit 3. Front power window switch RH circuit 4. Front power window regulator RH circuit 5. Front power window regulator RH 6. Front power window main switch 7. Front power window switch RH 	<ol style="list-style-type: none"> 1. Check power supply for front power window switch RH terminals 6 and 13. 2. Check front power window switch RH ground circuit. 3. Check harness between front power window switch RH and power window main switch. 4. Check harness between front power window switch RH and front power window regulator RH for open or short circuit. 5. Check front power window regulator RH. 6. Check front power window main switch. 7. Check front power window switch RH.
One or more rear power windows except front window cannot be operated.	<ol style="list-style-type: none"> 1. Rear power window switches 2. Rear power window regulators 3. Power window main switch 4. Rear power window circuit 	<ol style="list-style-type: none"> 1. Check rear power window switches. 2. Check rear power window regulator. 3. Check power window main switch. 4. Check the following. <ol style="list-style-type: none"> a. Harness between the rear power window switches terminal 5 and power window relay b. Harnesses between power window main switch and rear power window switches for open/short circuit c. Harnesses between rear power window switches and rear power window regulator for open/short circuit
Power windows except driver's side window cannot be operated using power window main switch but can be operated by power window switches.	<ol style="list-style-type: none"> 1. Power window main switch 	<ol style="list-style-type: none"> 1. Check power window main switch.
Driver side power window automatic operation does not function properly.	<ol style="list-style-type: none"> 1. Power window main switch 2. Encoder and limit switch 	<ol style="list-style-type: none"> 1. Check power window main switch. 2. Check encoder and limit switch. (EL-252)

POWER WINDOW

Trouble Diagnoses (Cont'd)

Symptom	Possible cause	Repair order	
Front passenger side power window automatic operation does not function properly.	<ol style="list-style-type: none"> 1. Front power window switch RH 2. Encoder and limit switch 	<ol style="list-style-type: none"> 1. Check front power window switch RH. 2. Check encoder and limit switch. (EL-252) 	GI
Retained power operation does not operate properly.	<ol style="list-style-type: none"> 1. RAP signal circuit 2. Driver or passenger side door switch circuit 3. Smart entrance control unit 	<ol style="list-style-type: none"> 1. Check harness between power window relay terminal 2 and smart entrance control unit terminal 5 for open or short circuit. 2. Check the following. <ol style="list-style-type: none"> a. Harness between smart entrance control unit and driver or passenger side door switch for short circuit b. Driver or passenger side door switch ground circuit c. Driver or passenger side door switch 3. Check smart entrance control unit. (EL-324) 	MA EM LC EC FE AT TF PD AX SU BR ST RS BT HA SC EL IDX

POWER WINDOW

Trouble Diagnoses (Cont'd)

ENCODER AND LIMIT SWITCH CHECK

=NBEL0221S01

1	CHECK DOOR WINDOW SLIDE MECHANISM	
<p>Check the following.</p> <ul style="list-style-type: none"> ● Obstacles in window, glass molding, etc. ● Worn or deformed glass molding ● Door sash tilted too far inward or outward ● Door window regulator <p style="text-align: center;">OK or NG</p>		
OK	▶	GO TO 2.
NG	▶	Remove obstacles or repair door window slide mechanism.

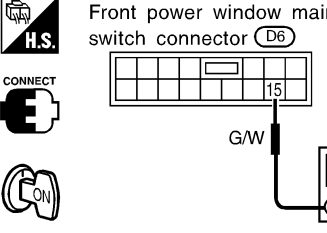
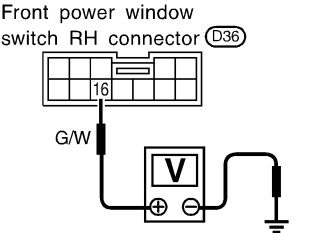
2	CHECK POWER SUPPLY TO LIMIT SWITCH	
<p>1. Disconnect front power window regulator LH or RH harness connector. 2. Check voltage between front power window main switch terminal 15 or front power window switch RH terminal 16 and ground.</p>		
<div style="display: flex; justify-content: space-around; align-items: center;"> <div style="text-align: center;">  <p>Front power window main switch connector (D6)</p> </div> <div style="text-align: center;">  <p>Front power window switch RH connector (D36)</p> </div> <div style="text-align: center;"> <p>Voltage: 5V</p> </div> </div> <p>NOTE: Check voltage when front power window regulator LH or RH harness connector is disconnected.</p> <p style="text-align: right;">SEL725WA</p> <p style="text-align: center;">OK or NG</p>		
OK	▶	GO TO 3.
NG	▶	Replace power window main switch or front power window switch RH.

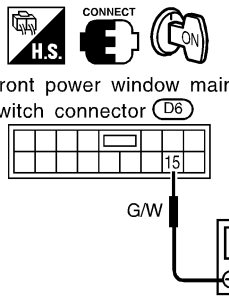
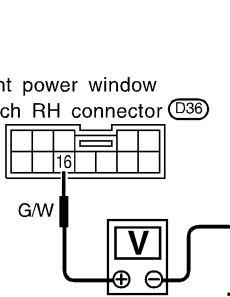
3	CHECK LIMIT SWITCH OPERATION										
<p>1. Connect front power window regulator LH or RH harness connector. 2. Check voltage between front power window main switch terminal 15 or front power window switch RH terminal 16 and ground during power window closing operation.</p>											
<div style="display: flex; justify-content: space-around; align-items: center;"> <div style="text-align: center;">  <p>Front power window main switch connector (D6)</p> </div> <div style="text-align: center;">  <p>Front power window switch RH connector (D36)</p> </div> <div style="border: 1px solid black; padding: 5px; margin-left: 20px;"> <table border="1" style="width: 100%; border-collapse: collapse;"> <thead> <tr> <th style="text-align: left;">Terminal No.</th> <th style="text-align: left;">Condition</th> <th style="text-align: left;">Voltage (DCV)</th> </tr> </thead> <tbody> <tr> <td>Front power window main switch: 15 Front power window switch RH: 16</td> <td>Approx. 15 mm (0.59 in) below the full closed position to full closed position</td> <td>Approx. 5</td> </tr> <tr> <td></td> <td>Other positions</td> <td>Approx. 0</td> </tr> </tbody> </table> </div> </div> <p style="text-align: right;">SEL726WA</p> <p style="text-align: center;">OK or NG</p>			Terminal No.	Condition	Voltage (DCV)	Front power window main switch: 15 Front power window switch RH: 16	Approx. 15 mm (0.59 in) below the full closed position to full closed position	Approx. 5		Other positions	Approx. 0
Terminal No.	Condition	Voltage (DCV)									
Front power window main switch: 15 Front power window switch RH: 16	Approx. 15 mm (0.59 in) below the full closed position to full closed position	Approx. 5									
	Other positions	Approx. 0									
OK	▶	GO TO 5.									
NG	▶	GO TO 4.									

POWER WINDOW

Trouble Diagnoses (Cont'd)

4 RESET LIMIT SWITCH

Reset limit switch. Refer to BT-19, "Front Door Glass Limit Switch Reset". Then check voltage between front power window main switch terminal 15 or front power window switch RH terminal 16 and ground during power window closing operation at least ten times.

Terminal No.	Condition	Voltage (DCV)
Front power window main switch: 15 Front power window switch RH: 16	Approx. 15 mm (0.59 in) below the full closed position to full closed position	Approx. 5
	Other positions	Approx. 0

SEL726WA

OK or NG

OK	▶	GO TO 5.
NG	▶	Replace power window regulator motor.

5 CHECK ENCODER

Measure voltage between front power window main switch terminal 14 or front power window switch RH terminal 19 and ground with oscilloscope when power window is in automatic closing operation.

HI: Approx. 5V
LO: Approx. 0V

SEL727WA

OK or NG

OK	▶	Replace power window main switch.
NG	▶	Replace power window regulator motor.

GI
MA
EM
LC
EC
FE
AT
TF
PD
AX
SU
BR
ST
RS
BT
HA
SC
EL
IDX

POWER DOOR LOCK

Component Parts and Harness Connector Location

Component Parts and Harness Connector Location

NBEL0106

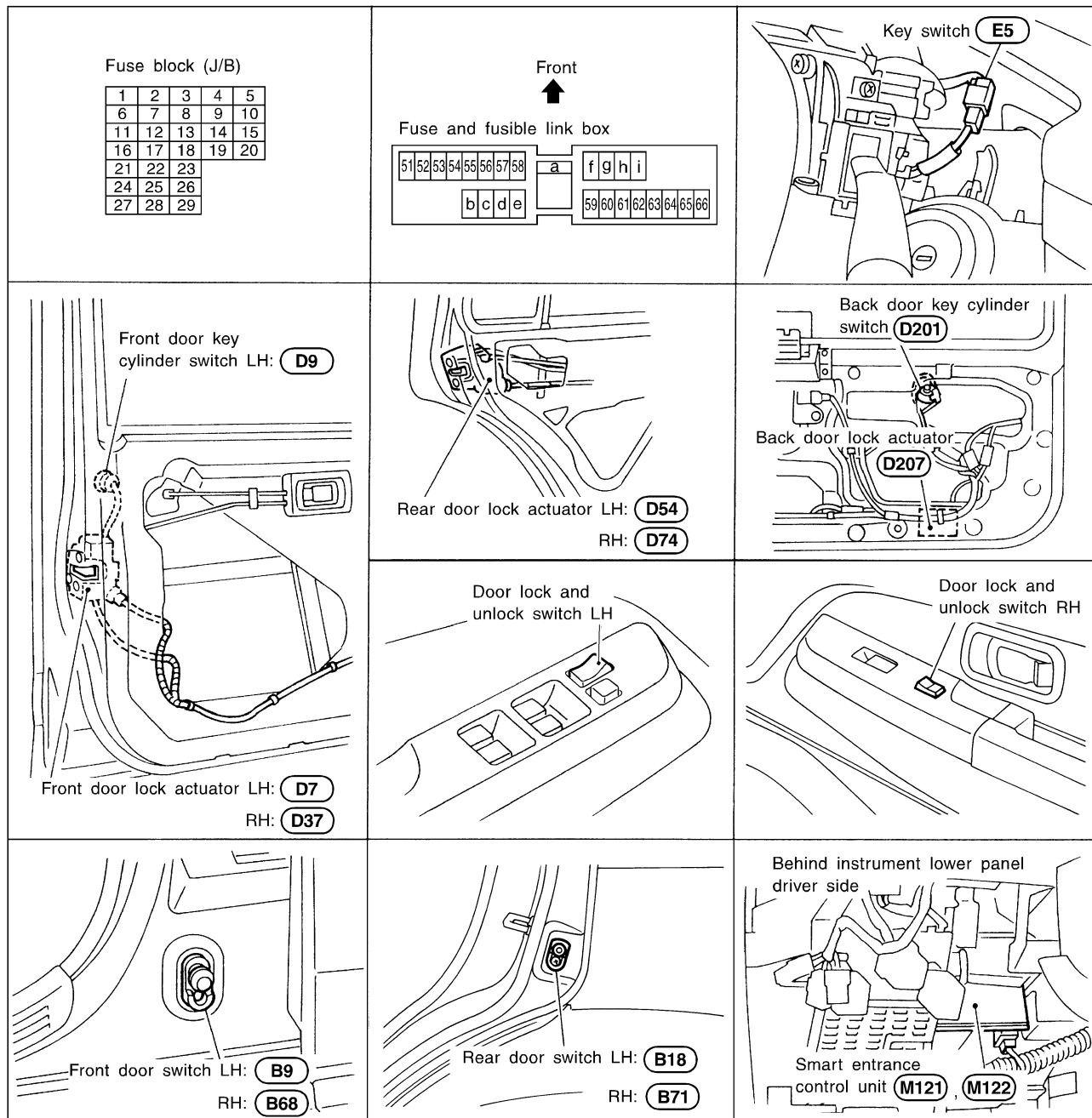

SEL065WA

System Description

NBEL0107

NBEL0107S04

OPERATION

- The lock/unlock switch (LH and RH) on door trim can lock and unlock all doors.
- With the door key inserted in the key cylinder on front LH or back door, turning it to "LOCK", will lock all doors; turning it to "UNLOCK" once unlocks the corresponding door; turning it to "UNLOCK" again within 5 seconds after the first unlock operation unlocks all of the other doors. (Signals from door key cylinder switch)
- If the ignition key is in the ignition key cylinder and one or more of doors are open, setting the lock/unlock switch to "LOCK" locks the doors once but then immediately unlock them. (Combination signals from key switch and door switches) - (KEY REMINDER DOOR SYSTEM)

POWER DOOR LOCK

Schematic

Schematic

NBEL0108

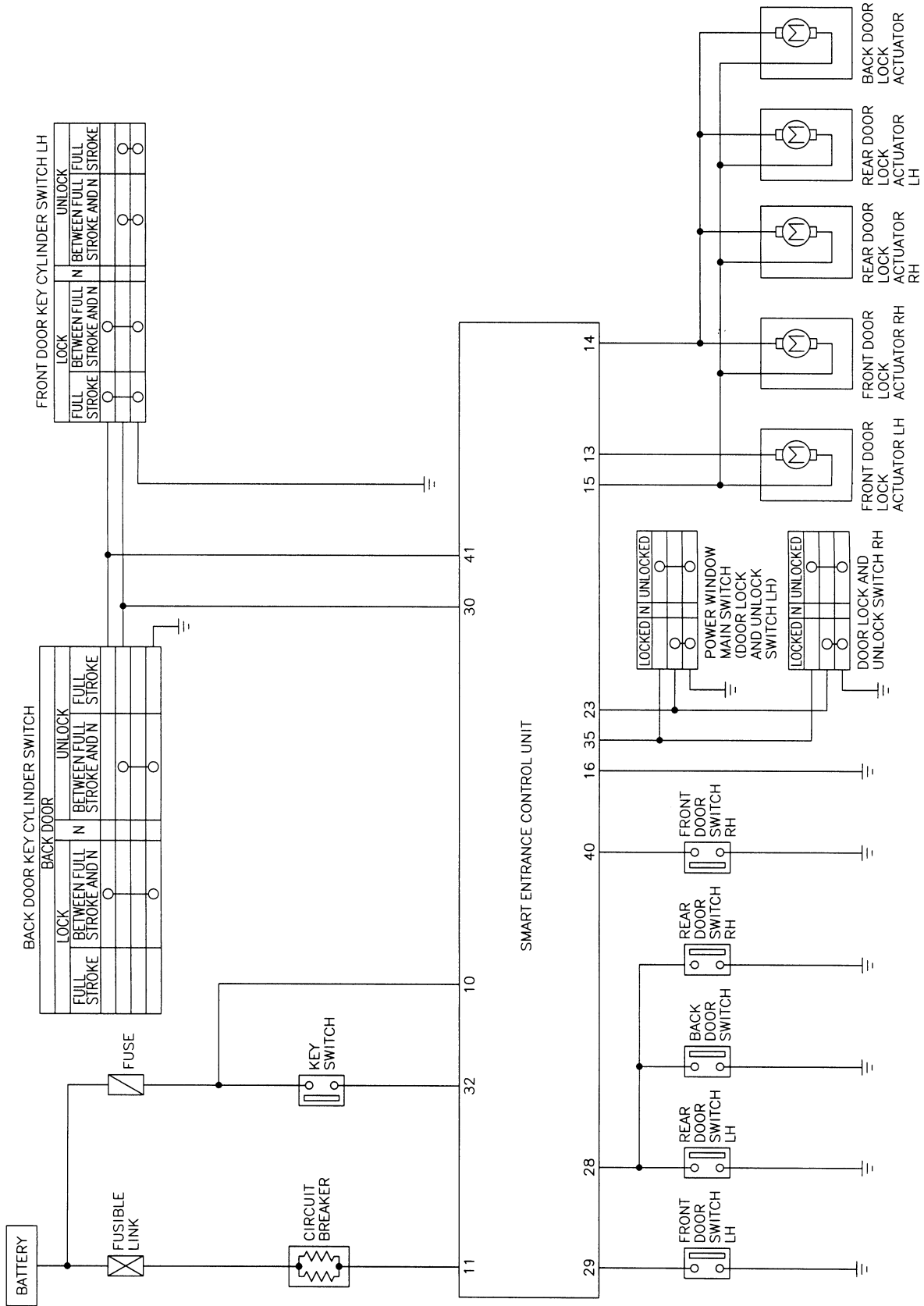

GI

MA

EM

LC

EC

FE

AT

TF

PD

AX

SU

BR

ST

RS

BT

HA

SC

EL

IDX

POWER DOOR LOCK

Wiring Diagram — D/LOCK —

Wiring Diagram — D/LOCK —

NBEL0109

NBEL0109S01

FIG. 1

EL-D/LOCK-01

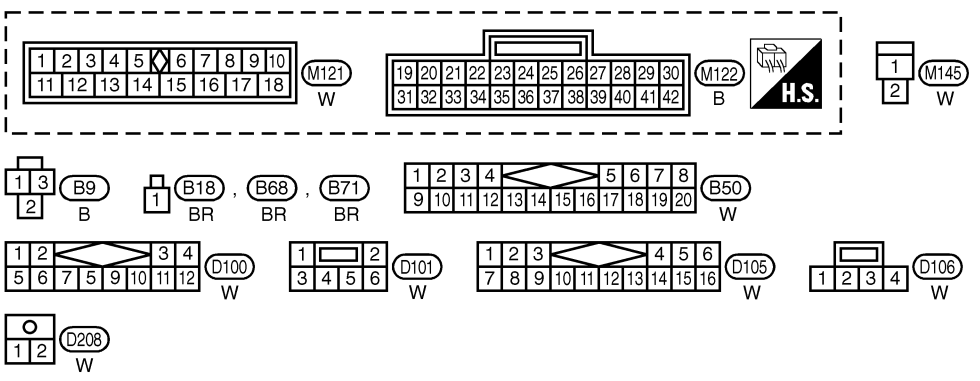
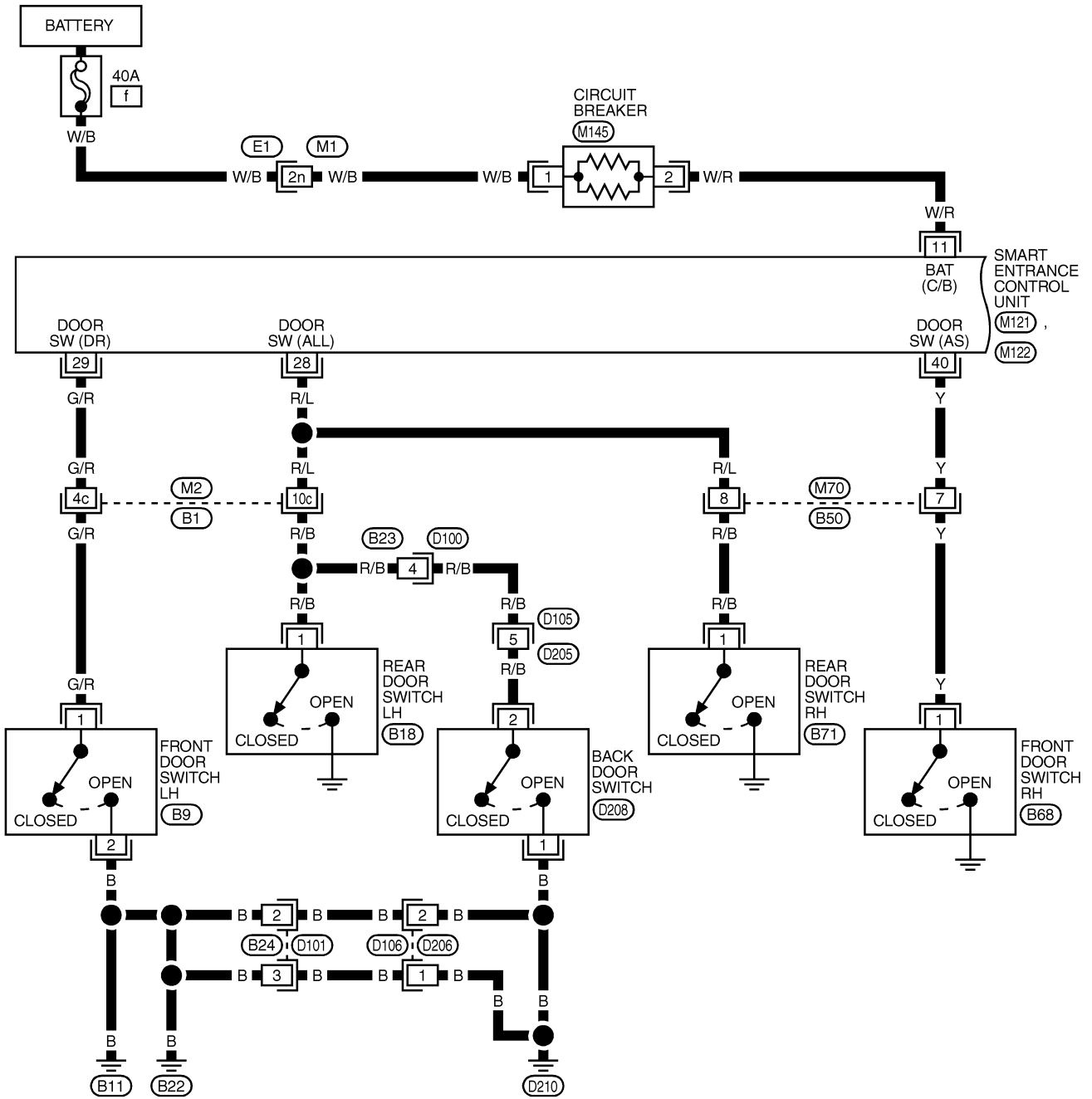

REFER TO THE FOLLOWING.
 (E1), (B1) -SUPER
 MULTIPLE JUNCTION (SMJ)

MEL848L

POWER DOOR LOCK

Wiring Diagram — D/LOCK — (Cont'd)

FIG. 2

NBEL0109S02

EL-D/LOCK-02

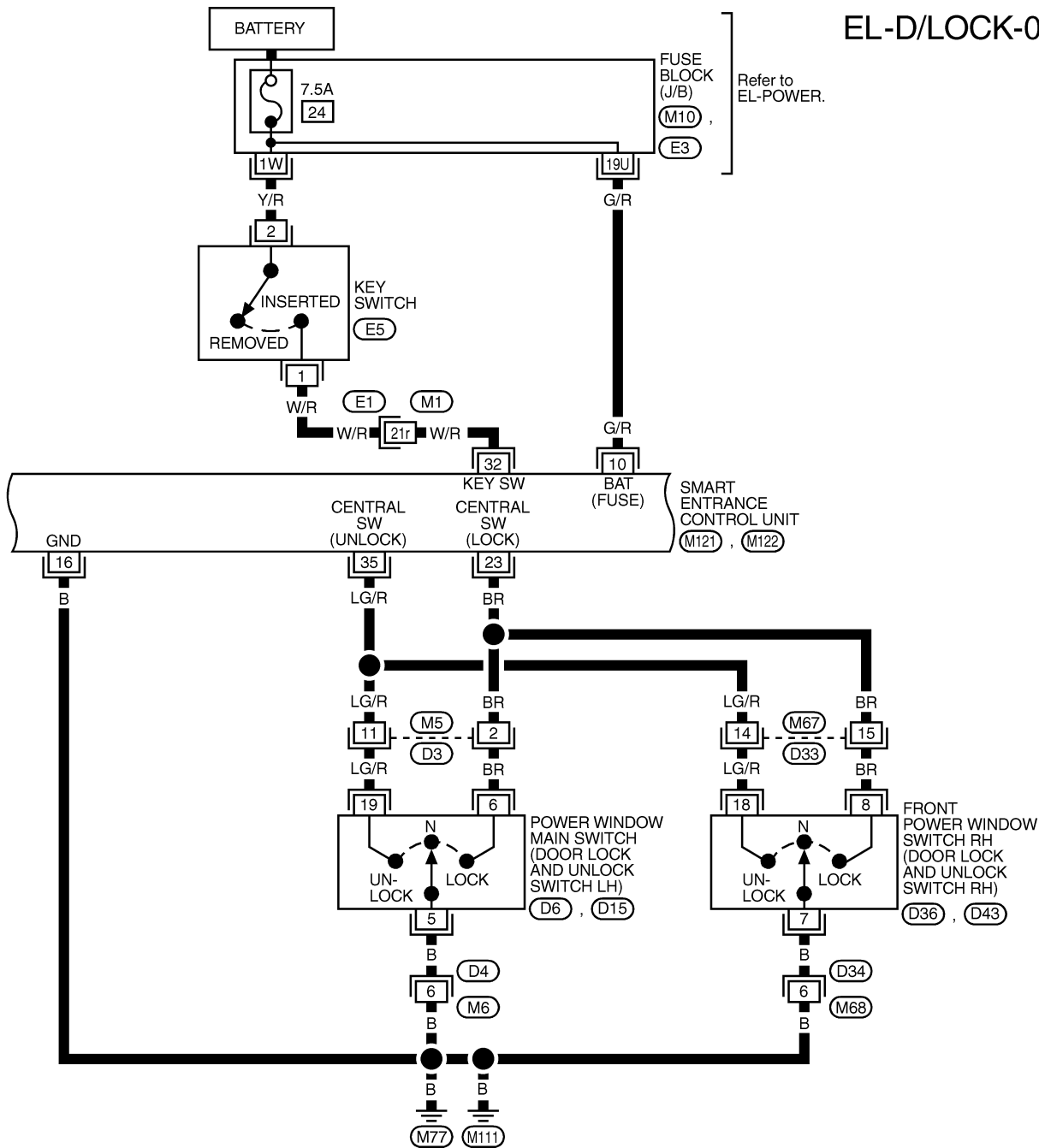

GI
MA
EM
LC
EC
FE
AT
TF
PD
AX
SU
BR
ST
RS
BT
HA
SC
EL
IDX

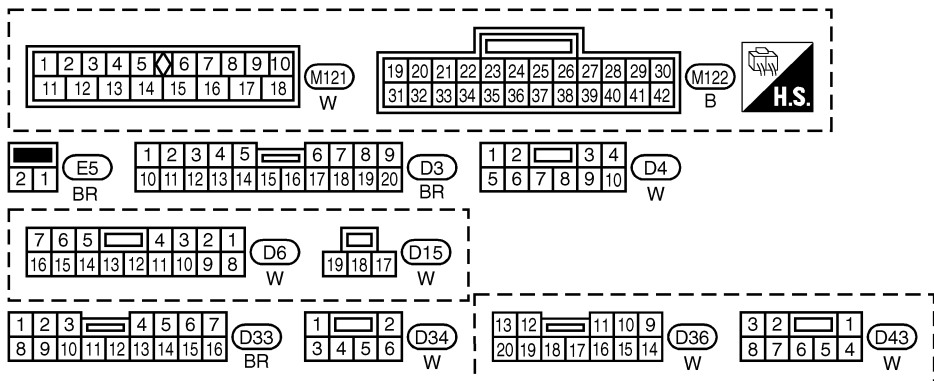

REFER TO THE FOLLOWING.
 (E1) -SUPER MULTIPLE JUNCTION (SMJ)
 (M10), (E3) -FUSE BLOCK-JUNCTION BOX (J/B)

MEL849L

POWER DOOR LOCK

Wiring Diagram — D/LOCK — (Cont'd)

FIG. 3

NBEL0109S03

EL-D/LOCK-03

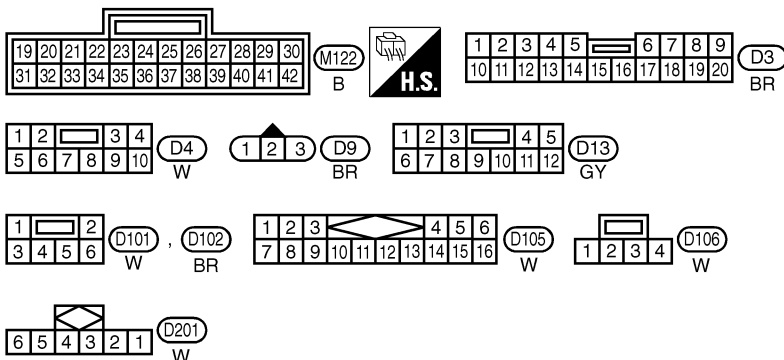
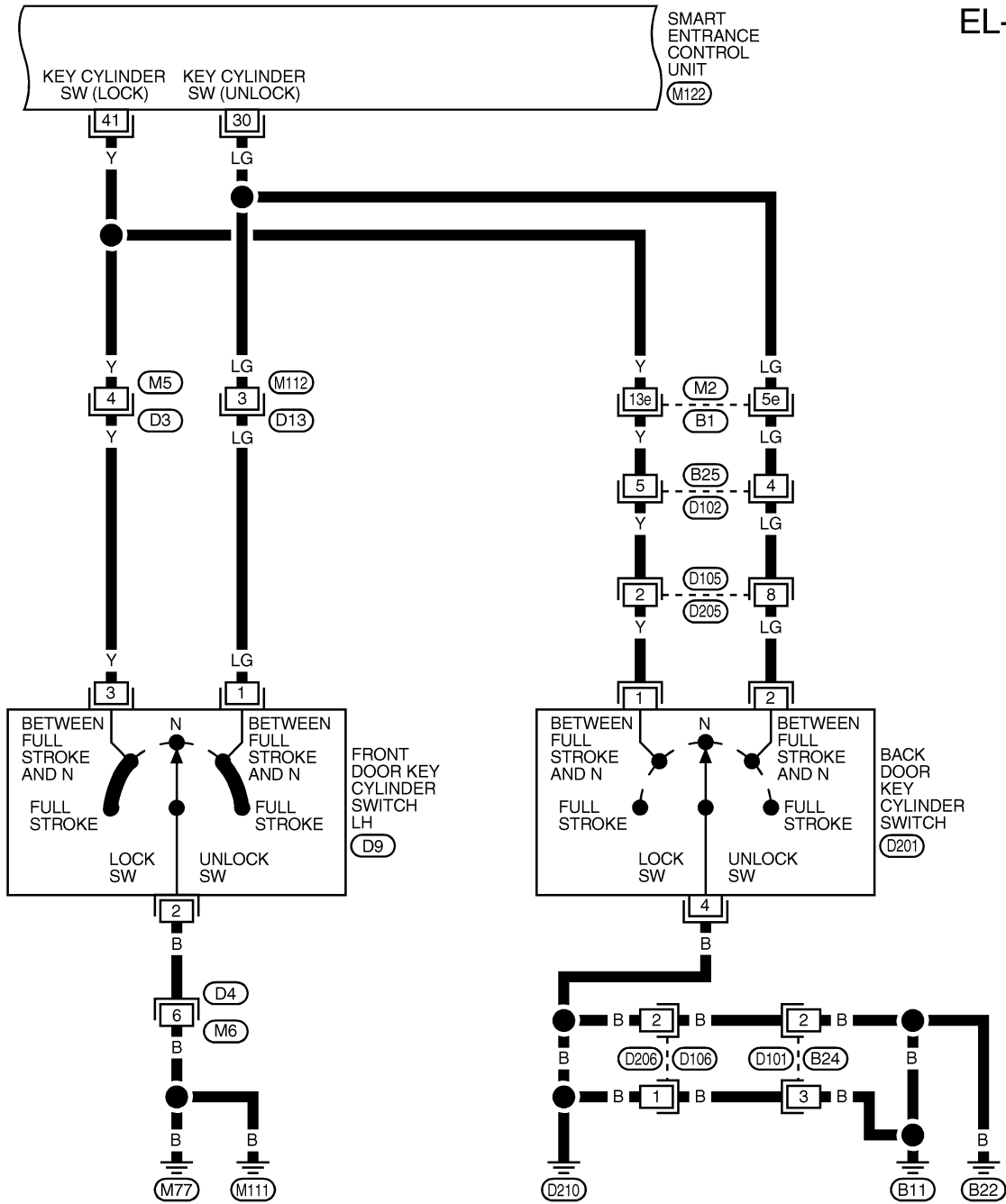

REFER TO THE FOLLOWING.

(B1) - SUPER MULTIPLE JUNCTION (SMJ)

MEL850L

POWER DOOR LOCK

Wiring Diagram — D/LOCK — (Cont'd)

FIG. 4

NBEL0109S04

EL-D/LOCK-04

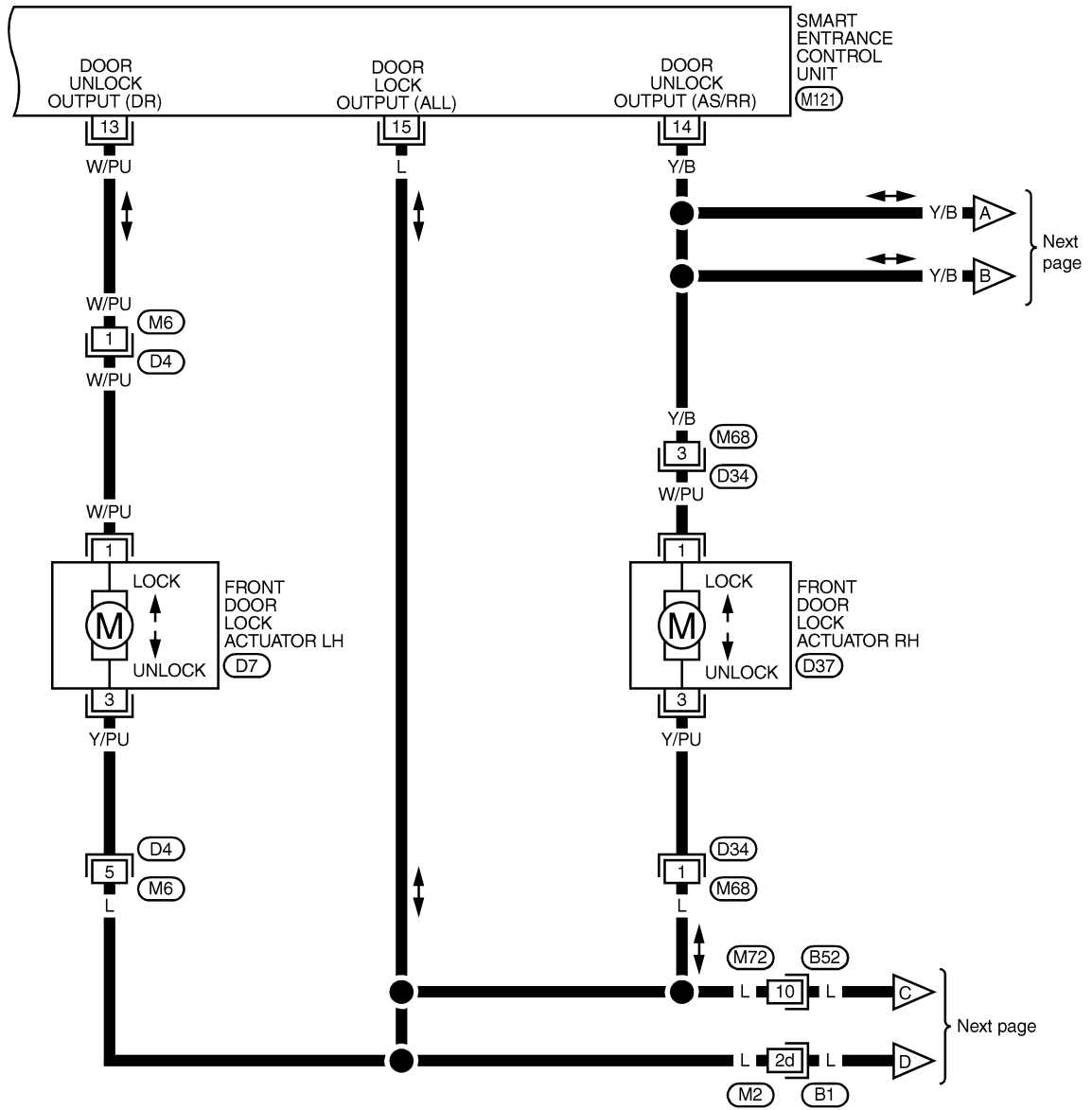

GI
MA
EM
LC
EC
FE
AT
TF
PD
AX
SU
BR
ST
RS
BT
HA
SC
EL
IDX

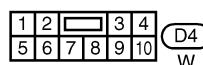
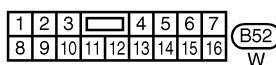
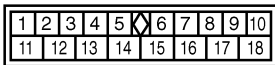

REFER TO THE FOLLOWING.

(B1) - SUPER MULTIPLE JUNCTION (SMJ)

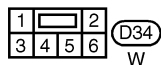
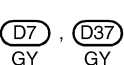

MEL851L

POWER DOOR LOCK

Wiring Diagram — D/LOCK — (Cont'd)

FIG. 5

NBEL0109S05

EL-D/LOCK-05

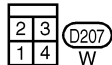
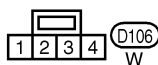
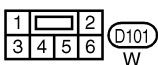
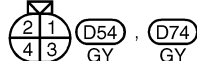
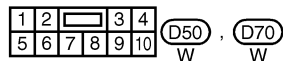
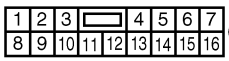
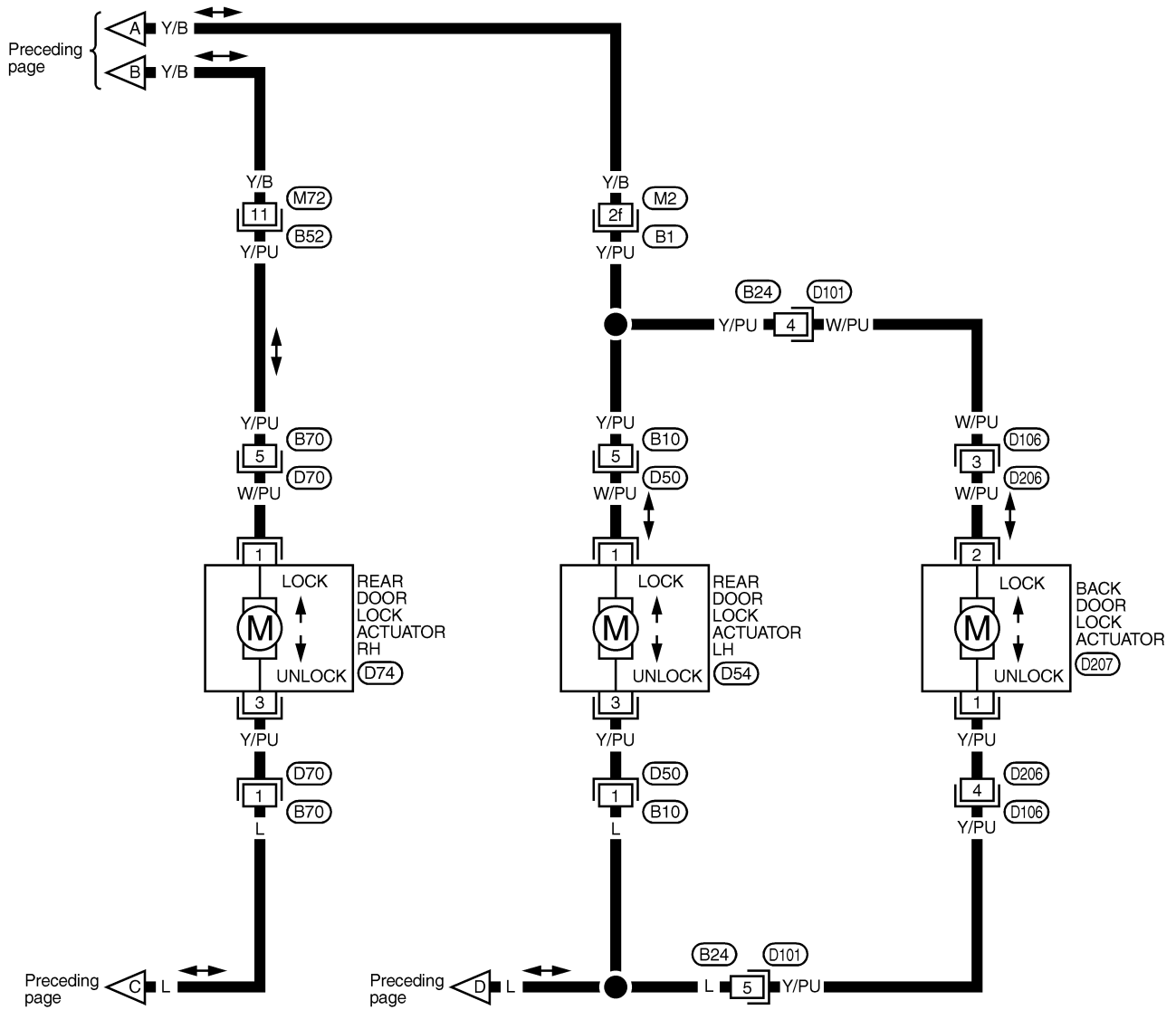

REFER TO THE FOLLOWING.

(B1) - SUPER MULTIPLE JUNCTION (SMJ)

MEL852L

POWER DOOR LOCK

Trouble Diagnoses

Trouble Diagnoses SYMPTOM CHART

NBEL0110

NBEL0110S01

REFERENCE PAGE (EL-)	262	263	264	265	266	267	268
SYMPTOM	MAIN POWER SUPPLY AND GROUND CIRCUIT CHECK	DOOR SWITCH CHECK	KEY SWITCH (INSERT) CHECK	DOOR LOCK/UNLOCK SWITCH CHECK	FRONT DOOR KEY CYLINDER SWITCH CHECK	BACK DOOR KEY CYLINDER SWITCH CHECK	DOOR LOCK ACTUATOR CHECK
Key reminder door system does not operate properly.	X	X	X				X
Specific door lock actuator does not operate.	X						X
Power door lock does not operate with door lock and unlock switch (LH and RH) on door trim.	X			X			
Power door lock does not operate with front door key cylinder operation.	X				X		
Power door lock does not operate with back door key cylinder operation.	X					X	

GI

MA

EM

LC

EC

FE

AT

TF

PD

AX

SU

BR

ST

RS

BT

HA

SC

EL

IDX

POWER DOOR LOCK

Trouble Diagnoses (Cont'd)

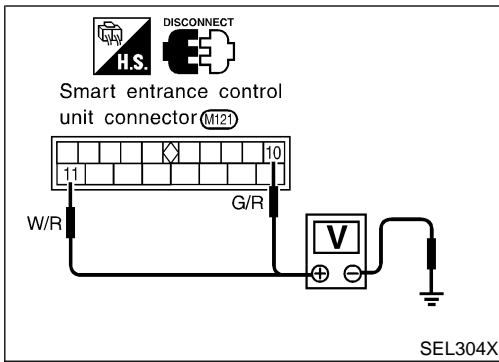

MAIN POWER SUPPLY AND GROUND CIRCUIT CHECK

=NBEL0110S02

Main Power Supply Circuit Check

NBEL0110S0201

Terminal		Ignition switch		
(+)	(-)	OFF	ACC	ON
10	Ground	Battery voltage	Battery voltage	Battery voltage
11				

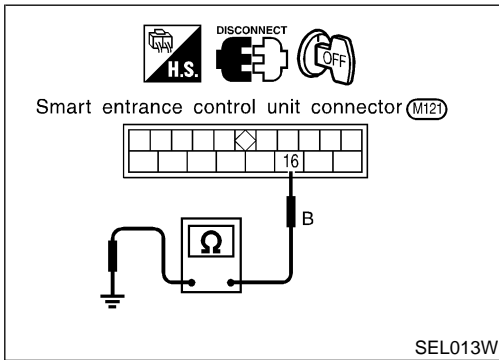

Ground Circuit Check

NBEL0110S0202



Terminals	Continuity
16 - Ground	Yes



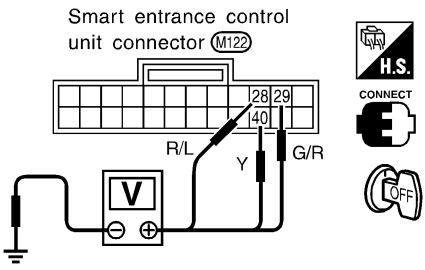

POWER DOOR LOCK

Trouble Diagnoses (Cont'd)

DOOR SWITCH CHECK

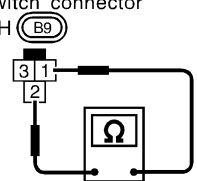
=NBEL0110S05

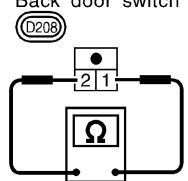
1	CHECK DOOR SWITCH INPUT SIGNAL	<p>Check voltage between smart entrance control unit terminals 28, 29 or 40 and ground.</p> <div style="display: flex; justify-content: space-around; align-items: flex-start;"> <div style="text-align: center;">  <p>Smart entrance control unit connector (M122)</p> </div> <div style="text-align: center;">  </div> </div> <table border="1" style="margin-top: 10px; border-collapse: collapse; width: 100%;"> <thead> <tr> <th rowspan="2"></th> <th colspan="2">Terminals</th> <th rowspan="2">Condition</th> <th rowspan="2">Voltage [V]</th> </tr> <tr> <th>(+)</th> <th>(-)</th> </tr> </thead> <tbody> <tr> <td rowspan="2">Front LH door switch</td> <td rowspan="2">29</td> <td rowspan="2">ground</td> <td>Open</td> <td>0</td> </tr> <tr> <td>Closed</td> <td>Approx. 5</td> </tr> <tr> <td rowspan="2">Front RH door switch</td> <td rowspan="2">40</td> <td rowspan="2">ground</td> <td>Open</td> <td>0</td> </tr> <tr> <td>Closed</td> <td>Approx. 5</td> </tr> <tr> <td rowspan="2">Rear and back door switches</td> <td rowspan="2">28</td> <td rowspan="2">ground</td> <td>Open</td> <td>0</td> </tr> <tr> <td>Closed</td> <td>Approx. 5</td> </tr> </tbody> </table> <p style="text-align: right; margin-top: 5px;">SEL305X</p>				Terminals		Condition	Voltage [V]	(+)	(-)	Front LH door switch	29	ground	Open	0	Closed	Approx. 5	Front RH door switch	40	ground	Open	0	Closed	Approx. 5	Rear and back door switches	28	ground	Open	0	Closed	Approx. 5
	Terminals		Condition	Voltage [V]																												
	(+)	(-)																														
Front LH door switch	29	ground	Open	0																												
			Closed	Approx. 5																												
Front RH door switch	40	ground	Open	0																												
			Closed	Approx. 5																												
Rear and back door switches	28	ground	Open	0																												
			Closed	Approx. 5																												
OK or NG																																
OK	▶	Door switch is OK.																														
NG	▶	GO TO 2.																														

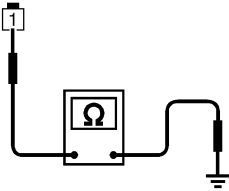
2	CHECK DOOR SWITCH	<p>1. Disconnect door switch connector. 2. Check continuity between door switch terminals.</p> <div style="display: flex; justify-content: space-around; align-items: flex-start;"> <div style="text-align: center;">  <p>Door switch connector Front LH (B9)</p>  </div> <div style="text-align: center;">  <p>Back door switch (D208)</p>  </div> <div style="text-align: center;">  <p>Door switch connector Front RH : (B68) Rear LH : (B18) Rear RH : (B71)</p>  </div> </div> <table border="1" style="margin-top: 10px; border-collapse: collapse; width: 100%;"> <thead> <tr> <th></th> <th>Terminals</th> <th>Condition</th> <th>Continuity</th> </tr> </thead> <tbody> <tr> <td rowspan="2">Front LH door switch</td> <td rowspan="2">1 - 2</td> <td>Closed</td> <td>No</td> </tr> <tr> <td>Open</td> <td>Yes</td> </tr> <tr> <td rowspan="2">Back door switch</td> <td rowspan="2">1 - 2</td> <td>Closed</td> <td>No</td> </tr> <tr> <td>Open</td> <td>Yes</td> </tr> <tr> <td rowspan="2">Front RH and rear door switches</td> <td rowspan="2">1 - ground</td> <td>Closed</td> <td>No</td> </tr> <tr> <td>Open</td> <td>Yes</td> </tr> </tbody> </table> <p style="text-align: right; margin-top: 5px;">SEL306X</p>				Terminals	Condition	Continuity	Front LH door switch	1 - 2	Closed	No	Open	Yes	Back door switch	1 - 2	Closed	No	Open	Yes	Front RH and rear door switches	1 - ground	Closed	No	Open	Yes
	Terminals	Condition	Continuity																							
Front LH door switch	1 - 2	Closed	No																							
		Open	Yes																							
Back door switch	1 - 2	Closed	No																							
		Open	Yes																							
Front RH and rear door switches	1 - ground	Closed	No																							
		Open	Yes																							
OK or NG																										
OK	▶	<p>Check the following.</p> <ul style="list-style-type: none"> ● Door switch ground circuit (Front LH, back door) or door switch ground condition ● Harness for open or short between smart entrance control unit and door switch 																								
NG	▶	Replace door switch.																								

GI
MA
EM
LC
EC
FE
AT
TF
PD
AX
SU
BR
ST
RS
BT
HA
SC
EL
IDX

POWER DOOR LOCK

Trouble Diagnoses (Cont'd)

KEY SWITCH (INSERT) CHECK

=NBEL0110S06

1	CHECK KEY SWITCH INPUT SIGNAL	
<p>Check voltage between smart entrance control unit terminal 32 and ground.</p>		
<div style="display: flex; justify-content: space-between; align-items: flex-start;"> <div style="width: 45%;"> <p>Smart entrance control unit connector (M122)</p> <p>W/R</p> <p>Approx. 12V</p> <p>0V</p> </div> <div style="width: 45%;"> <p>Voltage [V]:</p> <p>Condition of key switch: Key is inserted. Approx. 12</p> <p>Condition of key switch: Key is removed. 0</p> </div> </div>		
SEL307X		
OK or NG		
OK	▶	Key switch is OK.
NG	▶	GO TO 2.

2	CHECK KEY SWITCH (INSERT)	
<p>Check continuity between terminals 1 and 2.</p>		
<div style="display: flex; justify-content: space-between; align-items: flex-start;"> <div style="width: 45%;"> <p>Key switch connector (E5)</p> </div> <div style="width: 45%;"> <p>Continuity:</p> <p>Condition of key switch: Key is inserted. Yes</p> <p>Condition of key switch: Key is removed. No</p> </div> </div>		
SEL308X		
OK or NG		
OK	▶	<p>Check the following.</p> <ul style="list-style-type: none"> ● 7.5A fuse [No. 24, located in fuse block (J/B)] ● Harness for open or short between key switch and fuse ● Harness for open or short between smart entrance control unit and key switch
NG	▶	Replace key switch.

DOOR LOCK/UNLOCK SWITCH CHECK

=NBEL0110S03

1 CHECK DOOR LOCK/UNLOCK SWITCH INPUT SIGNAL

1. Disconnect smart entrance control unit connector.
2. Check continuity between control unit terminal 23 or 35 and ground.

Smart entrance control unit connector (M122)

BR

LG/R

DISCONNECT

H.S.

OFF

Terminals	Door lock/unlock switch (LH or RH) condition	Continuity
23 - ground	Lock	Yes
	N and Unlock	No
35 - ground	Unlock	Yes
	N and Lock	No

Refer to wiring diagram in EL-257.

SEL309X

OK or NG

OK	▶	Door lock/unlock switch is OK.
NG	▶	GO TO 2.

GI
MA
EM
LC
EC
FE
AT
TF
PD
AX
SU
BR
ST
RS
BT
HA
SC
EL
IDX

2 CHECK DOOR LOCK/UNLOCK SWITCH

1. Disconnect door lock/unlock switch connector.
2. Check continuity between each door lock/unlock switch terminals.
 - Power window main switch (Door lock/unlock switch LH)

P/W main switch connector

5 6 19

D6 D15

DISCONNECT

T.S.

Condition	Terminals		
	5	19	6
Lock	○	○	○
N	No continuity		
Unlock	○	○	○

● Door lock/unlock switch RH

Lock/unlock switch RH connector

18 7 8

D36 D43

DISCONNECT

T.S.

Condition	Terminals		
	7	18	8
Lock	○	○	○
N	No continuity		
Unlock	○	○	○

SEL310X

SEL311X

OK or NG

OK	▶	<p>Check the following.</p> <ul style="list-style-type: none"> ● Ground circuit for door lock/unlock switch ● Harness for open or short between door lock/unlock switch and smart entrance control unit connector
NG	▶	Replace door lock/unlock switch.

POWER DOOR LOCK

Trouble Diagnoses (Cont'd)

FRONT DOOR KEY CYLINDER SWITCH CHECK

=NBEL0110S07

1 CHECK DOOR KEY CYLINDER SWITCH INPUT SIGNAL (LOCK/UNLOCK SIGNAL)

Check voltage between smart entrance control unit terminals 30 or 41 and ground.

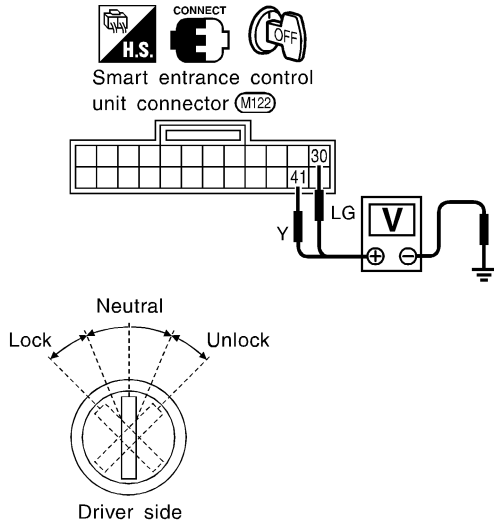

Terminals		Key position	Voltage [V]
(+)	(-)		
41	Ground	Neutral/Unlock	Approx. 5
		Lock	0
30	Ground	Neutral/Lock	Approx. 5
		Unlock	0

SEL312X

Refer to wiring diagram in EL-258.

OK or NG

OK ► Door key cylinder switch LH is OK.

NG ► GO TO 2.

2 CHECK DOOR KEY CYLINDER SWITCH

1. Disconnect door key cylinder switch connector.
2. Check continuity between door key cylinder switch terminals.

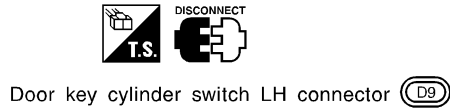

- ① : Door unlock switch terminal
- ② : Ground terminal
- ③ : Door lock switch terminal

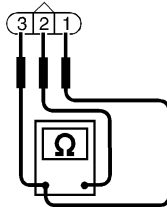

Terminals	Key position	Continuity
LH: 3 - 2	Neutral/Unlock	No
	Lock	Yes
LH: 1 - 2	Neutral/Lock	No
	Unlock	Yes

SEL313X

OK or NG

OK ► **Check the following.**

- Door key cylinder switch LH ground circuit
- Harness for open or short between smart entrance control unit and door key cylinder switch LH

NG ► Replace door key cylinder switch LH.

POWER DOOR LOCK

Trouble Diagnoses (Cont'd)

BACK DOOR KEY CYLINDER SWITCH CHECK

=NBEL0110S08

1	CHECK BACK DOOR KEY CYLINDER SWITCH INPUT SIGNAL (LOCK/UNLOCK SIGNAL)																						
<p>Check voltage between smart entrance control unit terminals 30 or 41 and ground.</p>																							
<div style="display: flex; justify-content: space-between;"> <div style="width: 45%;"> </div> <div style="width: 45%;"> <table border="1" style="width: 100%; border-collapse: collapse;"> <thead> <tr> <th rowspan="2"></th> <th colspan="2">Terminals</th> <th rowspan="2">Key position</th> <th rowspan="2">Voltage [V]</th> </tr> <tr> <th>(+)</th> <th>(-)</th> </tr> </thead> <tbody> <tr> <td rowspan="2">Back door</td> <td rowspan="2">41</td> <td rowspan="2">Ground</td> <td>Between neutral and lock</td> <td>0</td> </tr> <tr> <td>Other positions</td> <td>Approx. 5</td> </tr> <tr> <td rowspan="2"></td> <td rowspan="2">30</td> <td rowspan="2">Ground</td> <td>Between neutral and unlock</td> <td>0</td> </tr> <tr> <td>Other positions</td> <td>Approx. 5</td> </tr> </tbody> </table> </div> </div>				Terminals		Key position	Voltage [V]	(+)	(-)	Back door	41	Ground	Between neutral and lock	0	Other positions	Approx. 5		30	Ground	Between neutral and unlock	0	Other positions	Approx. 5
	Terminals			Key position	Voltage [V]																		
	(+)	(-)																					
Back door	41	Ground	Between neutral and lock	0																			
			Other positions	Approx. 5																			
	30	Ground	Between neutral and unlock	0																			
			Other positions	Approx. 5																			
<p>Refer to wiring diagram in EL-258. SEL314X</p>																							
OK or NG																							
OK	▶	Back door key cylinder switch is OK.																					
NG	▶	GO TO 2.																					

2	CHECK BACK DOOR KEY CYLINDER SWITCH																
<p>1. Disconnect back door key cylinder switch connector. 2. Check continuity between back door key cylinder switch terminals.</p>																	
<div style="display: flex; justify-content: space-between;"> <div style="width: 45%;"> </div> <div style="width: 45%;"> <table border="1" style="width: 100%; border-collapse: collapse;"> <thead> <tr> <th rowspan="2">Key position</th> <th colspan="3">Terminals</th> </tr> <tr> <th>1</th> <th>2</th> <th>4</th> </tr> </thead> <tbody> <tr> <td>Between neutral and lock (Back door)</td> <td style="text-align: center;">○</td> <td style="text-align: center;">—</td> <td style="text-align: center;">○</td> </tr> <tr> <td>Between neutral and unlock (Back door)</td> <td></td> <td style="text-align: center;">○</td> <td style="text-align: center;">○</td> </tr> </tbody> </table> </div> </div>			Key position	Terminals			1	2	4	Between neutral and lock (Back door)	○	—	○	Between neutral and unlock (Back door)		○	○
Key position	Terminals																
	1	2	4														
Between neutral and lock (Back door)	○	—	○														
Between neutral and unlock (Back door)		○	○														
SEL315X																	
OK or NG																	
OK	▶	<p>Check the following.</p> <ul style="list-style-type: none"> ● Back door key cylinder switch ground circuit ● Harness for open or short between smart entrance control unit and back door key cylinder switch 															
NG	▶	Replace back door key cylinder switch.															

GI
MA
EM
LC
EC
FE
AT
TF
PD
AX
SU
BR
ST
RS
BT
HA
SC
EL
IDX

POWER DOOR LOCK

Trouble Diagnoses (Cont'd)

DOOR LOCK ACTUATOR CHECK

=NBEL0110S04

1 CHECK DOOR LOCK ACTUATOR CIRCUIT

Check voltage for door lock actuator.

- Door lock actuator front LH

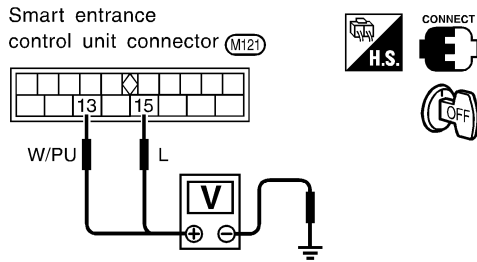

Door lock/unlock switch condition	Terminal No.		Voltage (V)
	(+)	(-)	
Lock	15	ground	Approx. 12
Unlock	13	ground	

SEL316X

- Door lock actuator front RH, rear and back

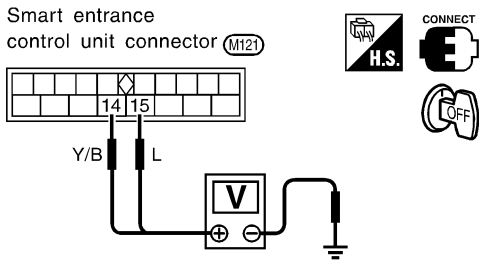

Door lock/unlock switch condition	Terminal No.		Voltage (V)
	(+)	(-)	
Lock	15	ground	Approx. 12
Unlock	14	ground	

SEL317X

Refer to wiring diagram in EL-259.

OK or NG

OK



GO TO 2.

NG

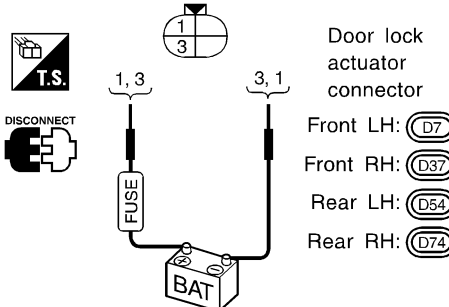
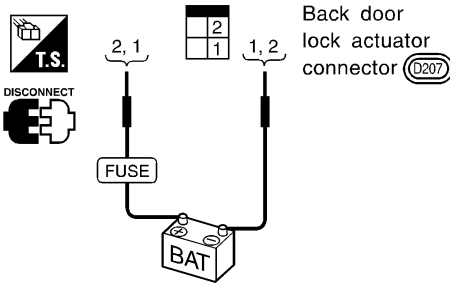

Replace smart entrance control unit. (Before replacing smart entrance control unit, perform "DOOR LOCK/UNLOCK SWITCH CHECK".)

2	CHECK DOOR LOCK ACTUATOR
	<p>1. Disconnect door lock actuator connector. 2. Apply 12V direct current to door lock actuator and check operation.</p> <div style="display: flex; justify-content: space-between;"> <div style="width: 45%;">  <p>Door lock actuator connector</p> <p>Front LH: (D7) Front RH: (D37) Rear LH: (D54) Rear RH: (D74)</p> </div> <div style="width: 45%;"> <p>• Door lock actuator operation: Terminals between (+): 3 and (-): 1 Unlocked → Locked Terminals between (+): 1 and (-): 3 Locked → Unlocked</p> </div> </div> <p style="text-align: right;">SEL318X</p> <div style="display: flex; justify-content: space-between; margin-top: 20px;"> <div style="width: 45%;">  <p>Back door lock actuator connector (D207)</p> </div> <div style="width: 45%;"> <p>• Back door lock actuator operation: Terminals between (+): 1 and (-): 2 Unlocked → Locked Terminals between (+): 2 and (-): 1 Locked → Unlocked</p> </div> </div> <p style="text-align: right;">SEL319X</p> <p style="text-align: center; margin-top: 10px;">OK or NG</p>
OK	▶ Check harness for open or short between smart entrance control unit connector and door lock actuator.
NG	▶ Replace door lock actuator.

GI
MA
EM
LC
EC
FE
AT
TF
PD
AX
SU
BR
ST
RS
BT
HA
SC
EL
IDX

MULTI-REMOTE CONTROL SYSTEM

Component Parts and Harness Connector Location

Component Parts and Harness Connector Location

NBEL0111

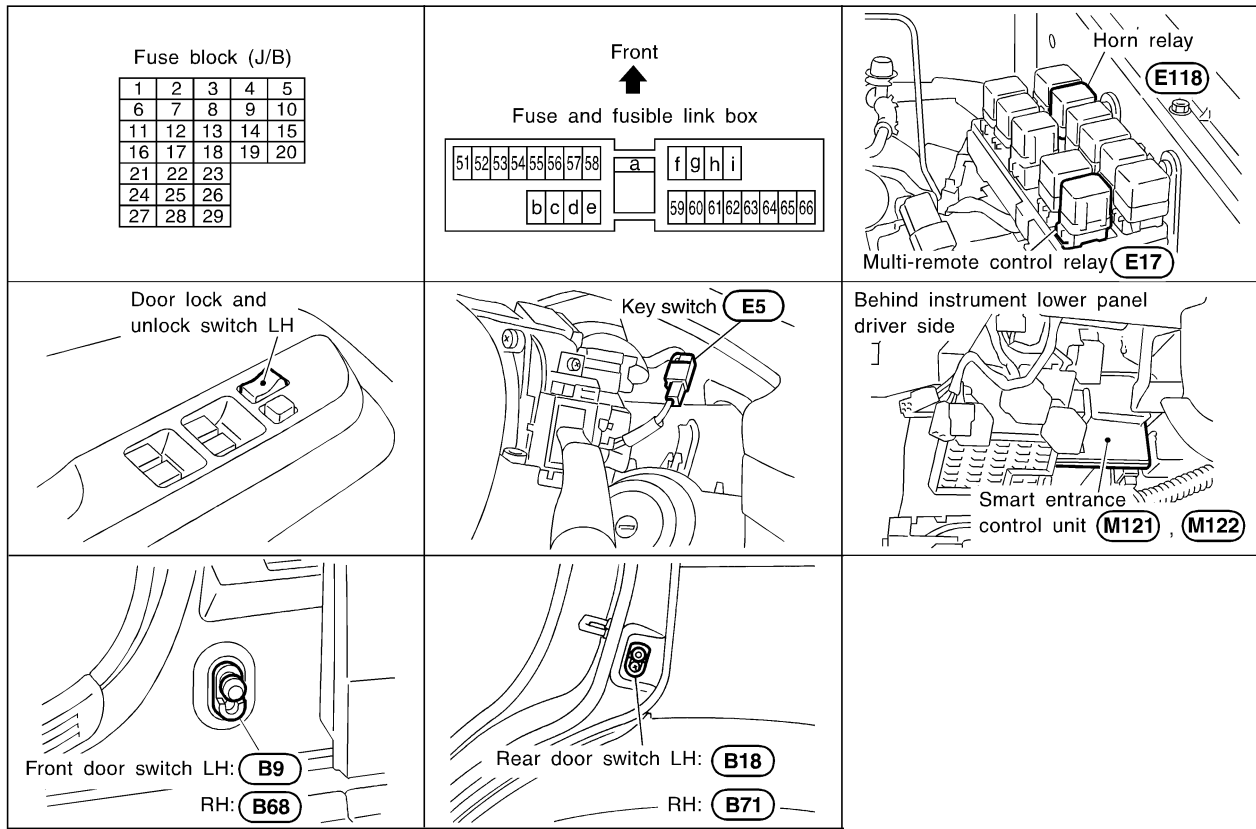

SEL355X

System Description

NBEL0112

NBEL0112S01

INPUTS

Power is supplied at all times

- to smart entrance control unit terminal 11
- through circuit breaker
- through 40A fusible link (letter f located in the fuse and fusible link box),
- to key switch terminal 2, and
- to smart entrance control unit terminal 10
- through 7.5A fuse [No. 24, located in the fuse block (J/B)].
- to multi-remote control relay terminals 1, 3 and 6
- through 15A fuse [No. 20, located in the fuse block (J/B)].
- to horn relay terminals 1 and 3
- through 7.5A fuse [No. 52, located in the fuse block (J/B)].
- to horn relay terminal 6
- through 10A fuse [No. 54, located in the fuse block (J/B)].

When the ignition switch is in the ACC or ON position, power is supplied to smart entrance control unit terminal 21.

When the key switch is ON (ignition key is inserted in key cylinder), power is supplied

- through key switch terminal 1
- to smart entrance control unit terminal 32.

MULTI-REMOTE CONTROL SYSTEM

System Description (Cont'd)

When the front door switch LH is OPEN, ground is supplied

- to smart entrance control unit terminal 29
- through front door switch LH terminal 1
- to front door switch LH terminal 2
- through body grounds B11, B22 and D210.

GI

When the front door switch RH is OPEN, ground is supplied

- to smart entrance control unit terminal 40
- through front door switch RH body ground.

MA

EM

When the other door switches are OPEN, ground is supplied

- to smart entrance control unit terminal 28
- through other door switches body grounds.

LC

Remote controller signal is inputted to smart entrance control unit (The antenna of the system is combined with smart entrance control unit).

EC

OPERATION

The multi-remote control system controls operation of the

NBEL0112S03

- power door lock
- interior lamp
- panic alarm
- hazard and horn reminder

FE

AT

OPERATED PROCEDURE

Power Door Lock Operation

Smart entrance control unit receives a LOCK signal from remote controller. Smart entrance control unit locks all doors with input of LOCK signal from remote controller.

NBEL0112S02

When an UNLOCK signal is sent from remote controller once, driver's door will be unlocked.

Then, if an UNLOCK signal is sent from remote controller again within 5 seconds, all other door will be unlocked.

TF

PD

AX

Hazard and Horn Reminder

When smart entrance control unit receives LOCK or UNLOCK signal from remote controller with all doors closed, ground is supplied

NBEL0112S0204

- to multi-remote control relay terminal 2
- through smart entrance control unit terminal 7, and
- to horn relay terminal 2
- through smart entrance control unit terminal 19

SU

BR

Multi-remote control relay and horn relay are now energized, and hazard warning lamp flashes and horn sounds as a reminder.

ST

RS

The hazard and horn reminder has a horn chirp mode (C mode) and a non-horn chirp mode (S mode).

Operating function of hazard and horn reminder

	Horn chirp mode (C mode)		Non-horn chirp mode (S mode)	
	Hazard warning lamp flash	Horn sound	Hazard warning lamp flash	Horn sound
Lock	Twice	Once	Twice	—
Unlock	Once	—	—	—

BT

HA

SC

How to change hazard and horn reminder mode

When LOCK and UNLOCK signals are sent from the remote controller for more than 2 seconds at the same time, the hazard and horn reminder mode is changed and hazard warning lamp flashes and horn sounds as follows:

EL

IDX

MULTI-REMOTE CONTROL SYSTEM

System Description (Cont'd)

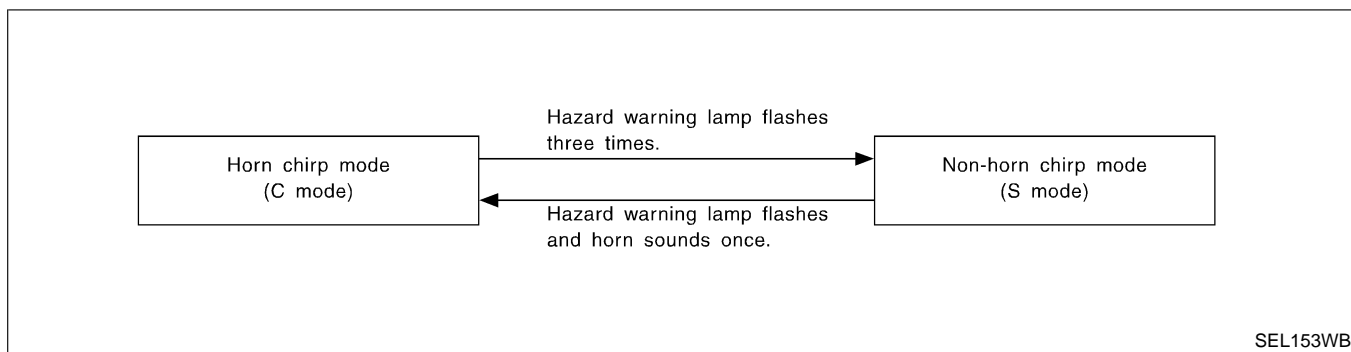

Interior Lamp Operation

NBEL0112S0202

When the following input signals are both supplied:

- door switch CLOSED (when all the doors are closed);
- driver's door LOCKED;

multi-remote control system turns on interior lamp (for 30 seconds) with input of UNLOCK signal from remote controller.

For detailed description, refer to "INTERIOR, SPOT, VANITY MIRROR AND LUGGAGE ROOM LAMPS" (EL-88).

Panic Alarm Operation

NBEL0112S0203

When key switch is OFF (when ignition key is not inserted in key cylinder), multi-remote control system turns on and off horn and headlamp intermittently with input of PANIC ALARM signal from remote controller.

For detailed description, refer to "THEFT WARNING SYSTEM" (EL-297).

MULTI-REMOTE CONTROL SYSTEM

Schematic

Schematic

NBEL0113

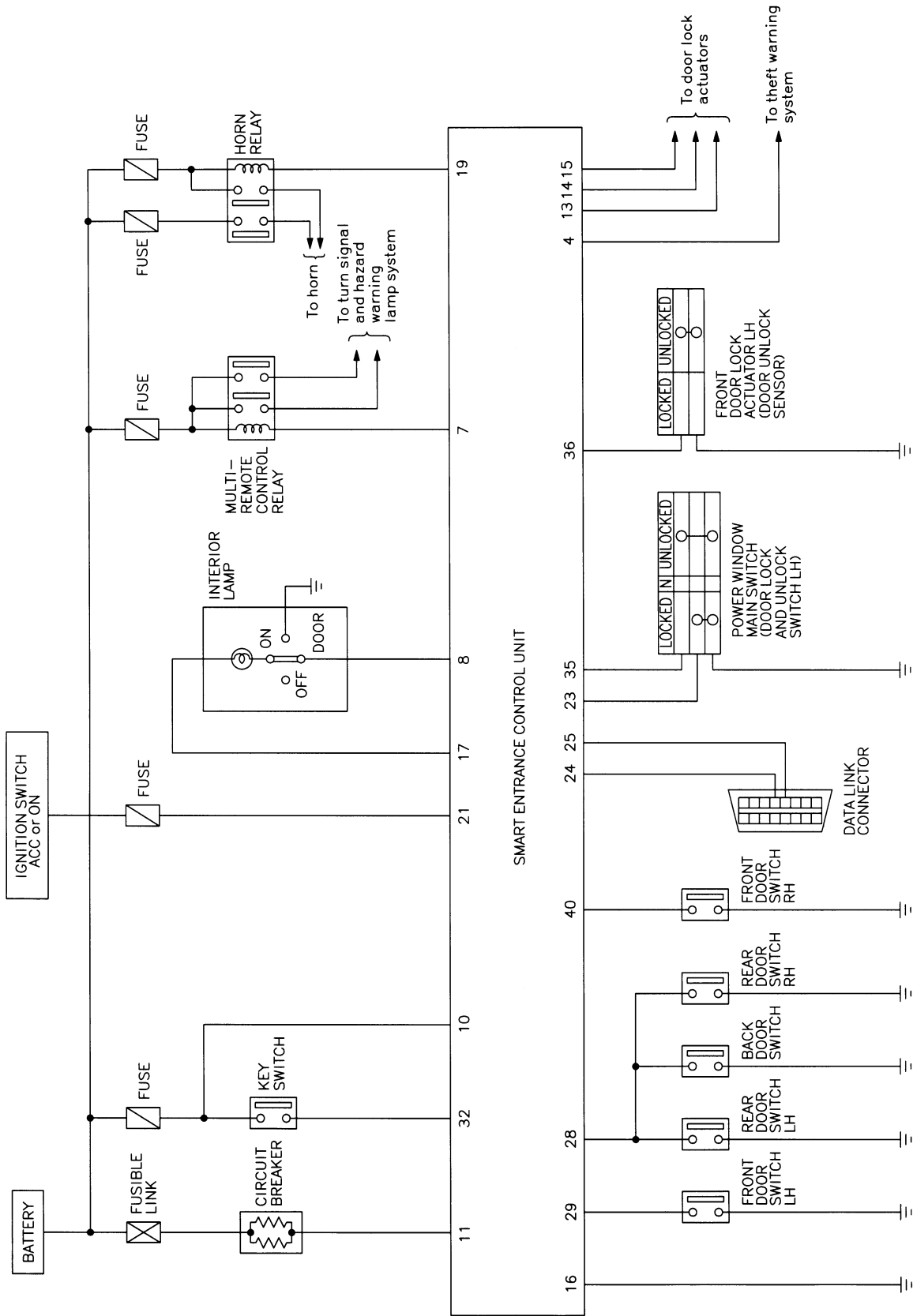

GI

MA

EM

LC

EC

FE

AT

TF

PD

AX

SU

BR

ST

RS

BT

HA

SC

EL

IDX

MEL853L

MULTI-REMOTE CONTROL SYSTEM

Wiring Diagram — MULTI —

Wiring Diagram — MULTI —

NBEL0114

NBEL0114S01

FIG. 1

EL-MULTI-01

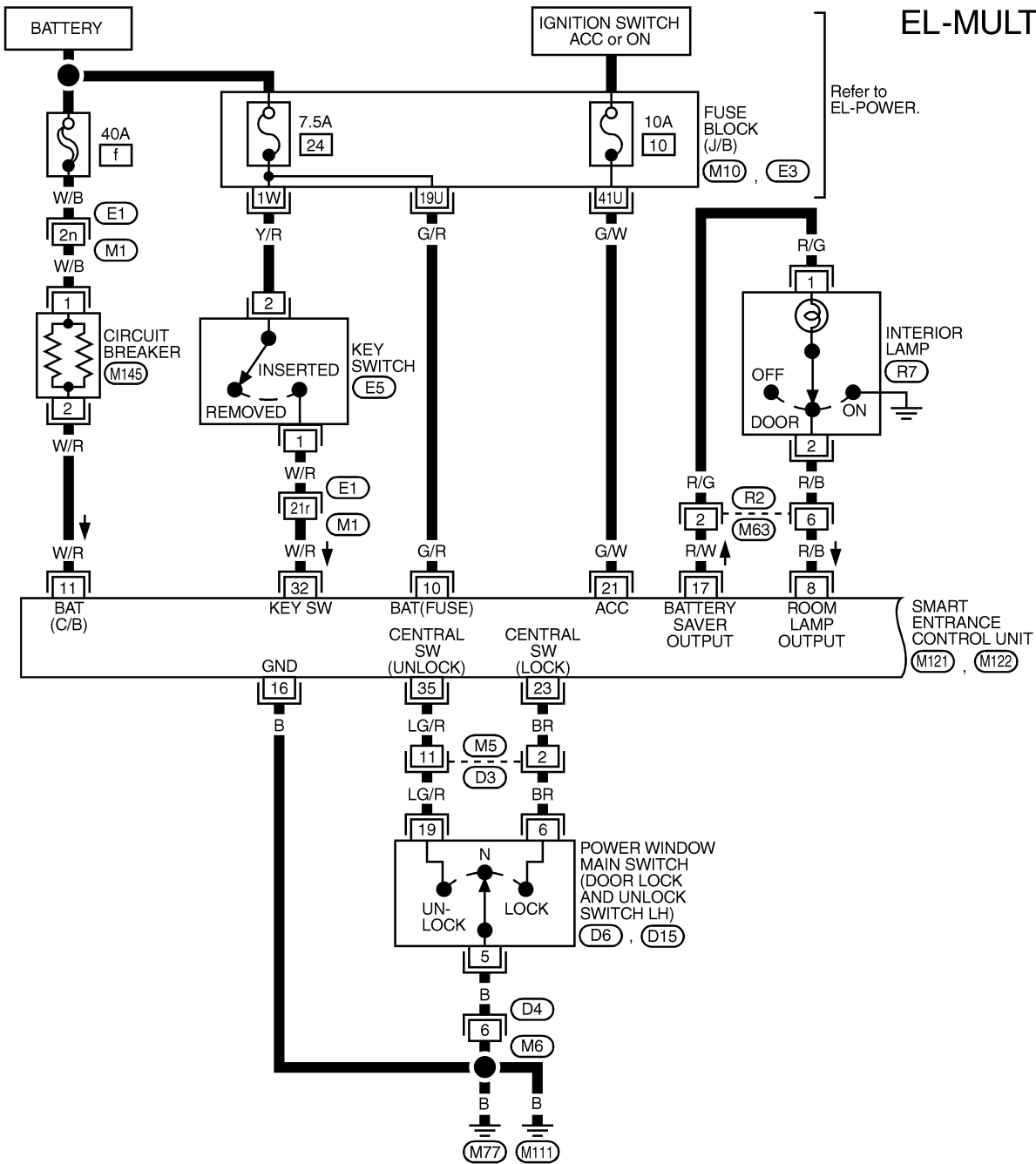

REFER TO THE FOLLOWING.

- (E1) - SUPER MULTIPLE JUNCTION (SMJ)
- (M10), (E3) - FUSE BLOCK - JUNCTION BOX (J/B)

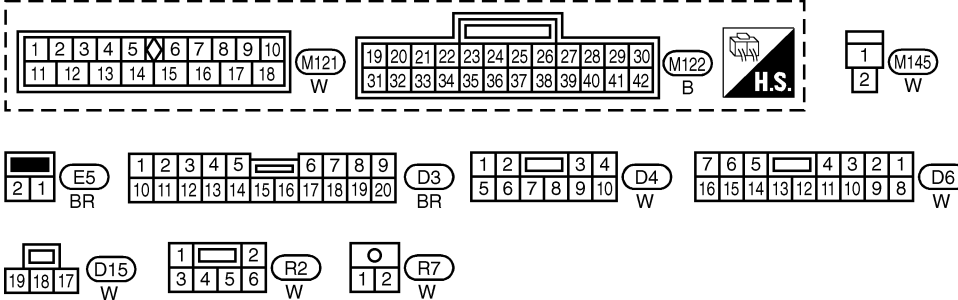

MEL854L

MULTI-REMOTE CONTROL SYSTEM

Wiring Diagram — MULTI — (Cont'd)

FIG. 2

NBEL0114S02

EL-MULTI-02

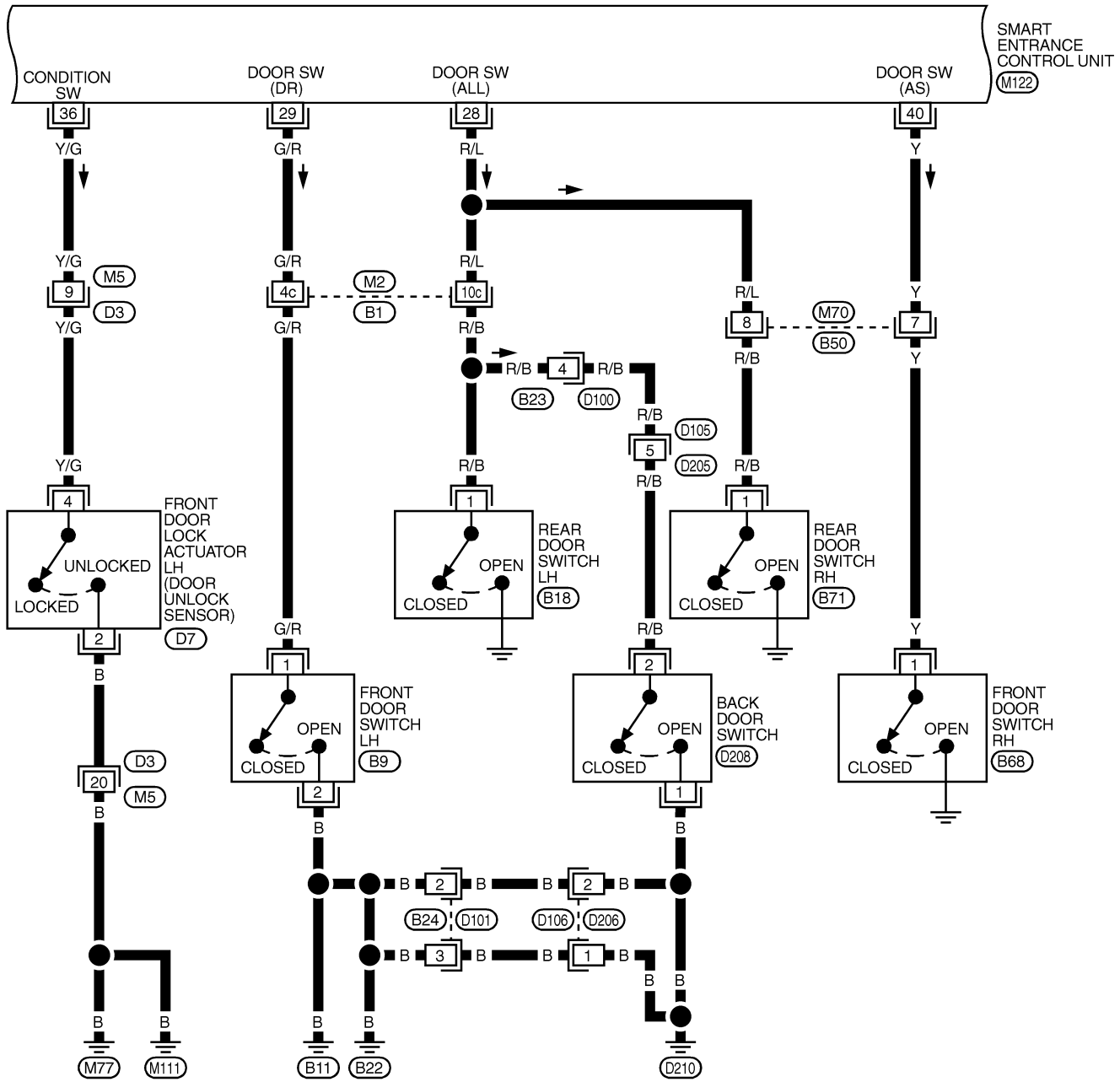

GI
MA
EM
LC
EC
FE
AT
TF
PD
AX
SU
BR
ST
RS
BT
HA
SC
EL
IDX

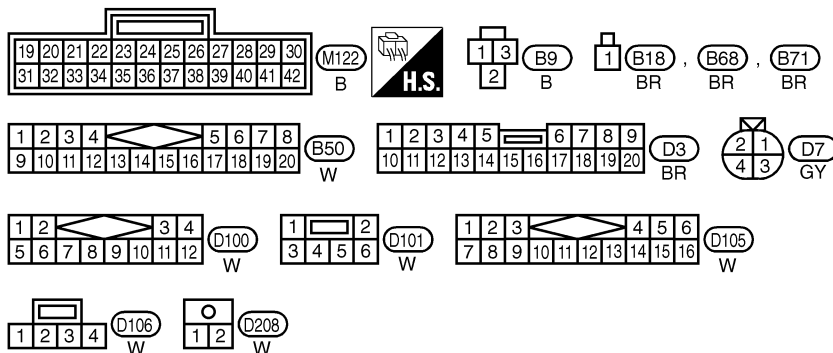

REFER TO THE FOLLOWING.
 (B1) -SUPER MULTIPLE JUNCTION (SMJ)

MEL855L

MULTI-REMOTE CONTROL SYSTEM

Wiring Diagram — MULTI — (Cont'd)

NBEL0114S03

FIG. 3

EL-MULTI-03

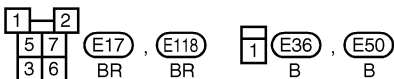
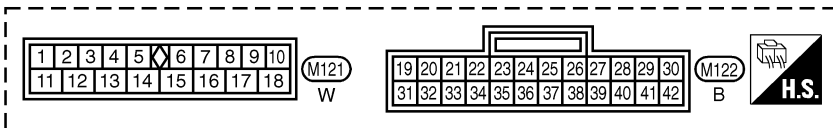
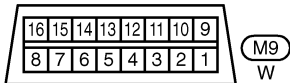
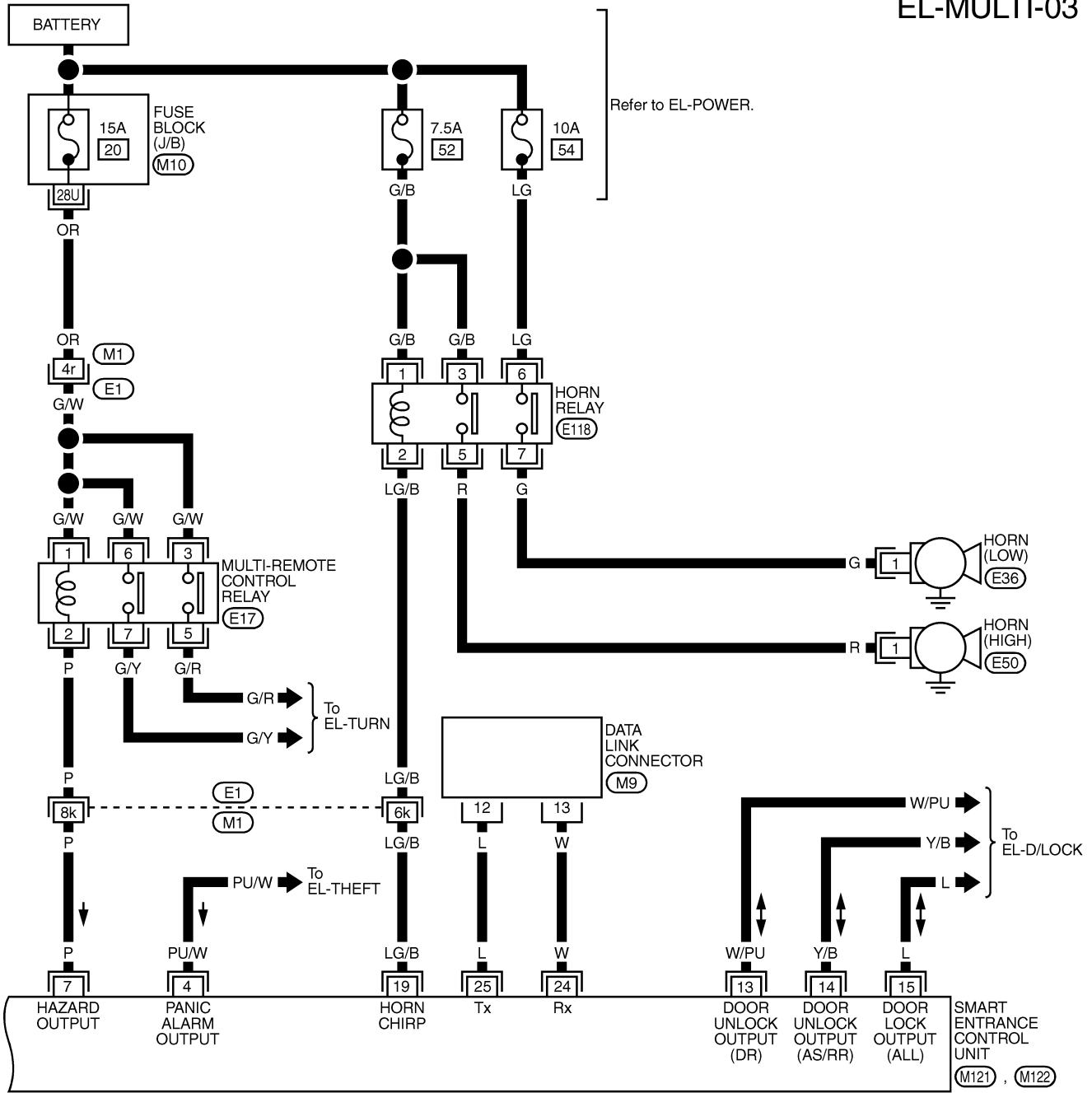

REFER TO THE FOLLOWING.

- (M1) - SUPER
- MULTIPLE JUNCTION (SMJ)
- (M10) - FUSE BLOCK-
- JUNCTION BOX (J/B)

MEL856L

MULTI-REMOTE CONTROL SYSTEM

Trouble Diagnoses

Trouble Diagnoses

SYMPTOM CHART

NBEL0115

NBEL0115S01

NOTE:

- Always check remote controller battery before replacing remote controller.
- The panic alarm operation of multi-remote control system does not activate with the ignition key inserted in the ignition key cylinder.

Symptom	Diagnoses/service procedure	Reference page (EL-)
All function of multi-remote control system do not operate.	1. Remote controller battery check	278
	2. Power supply and ground circuit for control unit check	279
	3. Replace remote controller. Refer to ID Code Entry Procedure.	291
The new ID of remote controller cannot be entered.	1. Remote controller battery check	278
	2. Key switch (insert) check	282
	3. Door switch check	281
	4. Door lock/unlock switch LH check	283
	5. Power supply and ground circuit for control unit check	279
	6. Replace remote controller. Refer to ID Code Entry Procedure.	291
Door lock or unlock does not function. (If the power door lock system does not operate manually, check power door lock system. Refer to EL-261.)	1. Replace remote controller. Refer to ID Code Entry Procedure.	291
Hazard and horn reminder does not activate properly when pressing lock or unlock button of remote controller.	1. Hazard reminder check	285
	2. Horn reminder check* *: Horn chirp can be activated or deactivated. First check the horn chirp setting. Refer to "System Description", EL-270.	287
	3. Door switch check	281
	4. Replace remote controller. Refer to ID Code Entry Procedure.	291
Interior lamp operation does not activate properly.	1. Interior room lamp operation check	288
	2. Door switch check	281
	3. Front LH door unlock sensor check	284
Panic alarm (horn and headlamp) does not activate when panic alarm button is continuously pressed.	1. Theft warning operation check. Refer to "PRELIMINARY CHECK" in "THEFT WARNING SYSTEM".	306
	2. Key switch (insert) check	282
	3. Replace remote controller. Refer to ID Code Entry Procedure.	291

GI

MA

EM

LC

EC

FE

AT

TF

PD

AX

SU

BR

ST

RS

BT

HA

SC

EL

IDX

MULTI-REMOTE CONTROL SYSTEM

Trouble Diagnoses (Cont'd)

REMOTE CONTROLLER BATTERY CHECK

=NBEL0115S02

1 CHECK REMOTE CONTROLLER BATTERY

Remove battery (refer to EL-293) and measure voltage across battery positive and negative terminals, (+) and (-).

Voltage [V]:
2.5 - 3.0

NOTE:

Remote controller does not function if battery is not set correctly.

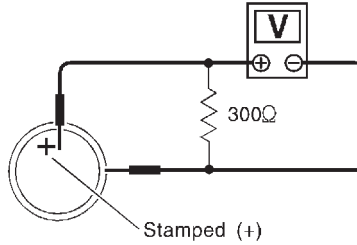

SEL277V

OK or NG

OK	▶	Check remote controller battery terminals for corrosion or damage.
NG	▶	Replace battery.

MULTI-REMOTE CONTROL SYSTEM

Trouble Diagnoses (Cont'd)

POWER SUPPLY AND GROUND CIRCUIT CHECK

=NBEL0115S04

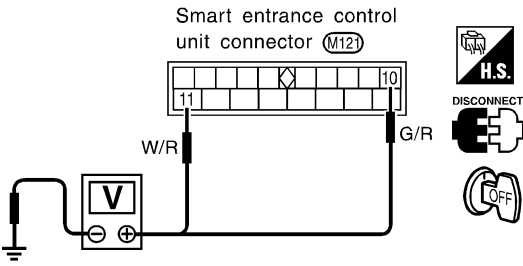
1	CHECK MAIN POWER SUPPLY CIRCUIT FOR CONTROL UNIT		GI
		<p>1. Disconnect connector from control unit. 2. Check voltage between smart entrance control unit terminal 10 or 11 and ground.</p>  <p style="text-align: right;">Battery voltage should exist.</p> <p style="text-align: right;">SEL320X</p> <p>Refer to wiring diagram in EL-274.</p> <p style="text-align: center;">OK or NG</p>	MA EM LC EC FE
OK	▶	GO TO 2.	AT
NG	▶	<p>Check the following.</p> <ul style="list-style-type: none"> ● 40A fusible link (letter f, located in fuse and fusible link box) ● 7.5A fuse [No. 24, located in fuse block (J/B)] ● M145 circuit breaker ● Harness for open or short between smart entrance control unit and fuse 	TF PD

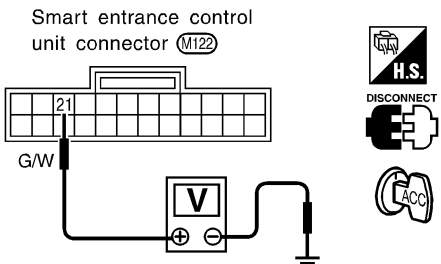
2	CHECK IGNITION SWITCH “ACC” CIRCUIT		AX
		<p>1. Disconnect smart entrance control unit connector. 2. Check voltage between control unit terminal 21 and ground while ignition switch is “ACC”.</p>  <p style="text-align: right;">Battery voltage should exist.</p> <p style="text-align: right;">SEL321X</p> <p>Refer to wiring diagram in EL-274.</p> <p style="text-align: center;">OK or NG</p>	SU BR ST RS
OK	▶	GO TO 3.	BT
NG	▶	<p>Check the following.</p> <ul style="list-style-type: none"> ● 10A fuse [No. 10, located in fuse block (J/B)] ● Harness for open or short between smart entrance control unit and fuse 	HA SC

EL

IDX

MULTI-REMOTE CONTROL SYSTEM

Trouble Diagnoses (Cont'd)

3	CHECK GROUND CIRCUIT FOR CONTROL UNIT	
<p>Check continuity between terminal 16 and ground.</p> <div style="display: flex; justify-content: space-around; align-items: center;"> <div data-bbox="300 262 576 535"> <p>Smart entrance control unit connector (M121)</p> </div> <div data-bbox="625 294 706 493"> </div> <div data-bbox="958 378 1258 420"> <p>Continuity should exist.</p> </div> </div> <p style="text-align: right;">SEL322X</p> <p>Refer to wiring diagram in EL-274.</p> <p style="text-align: center;">OK or NG</p>		
OK	▶	Power supply and ground circuits are OK.
NG	▶	Check ground harness.

MULTI-REMOTE CONTROL SYSTEM

Trouble Diagnoses (Cont'd)

DOOR SWITCH CHECK

=NBEL0115S05

1	CHECK DOOR SWITCH INPUT SIGNAL	<p>Check voltage between smart entrance control unit terminals 28, 29 or 40 and ground.</p> <div style="display: flex; justify-content: space-around; align-items: flex-start;"> <div style="text-align: center;"> <p>Smart entrance control unit connector (M122)</p> </div> <div style="text-align: center;"> <p>H.S. CONNECT</p> </div> </div> <table border="1" style="margin-top: 10px; border-collapse: collapse; width: 100%;"> <thead> <tr> <th rowspan="2"></th> <th colspan="2">Terminals</th> <th rowspan="2">Condition</th> <th rowspan="2">Voltage [V]</th> </tr> <tr> <th>(+)</th> <th>(-)</th> </tr> </thead> <tbody> <tr> <td rowspan="2">Front LH door switch</td> <td rowspan="2">29</td> <td rowspan="2">ground</td> <td>Open</td> <td>0</td> </tr> <tr> <td>Closed</td> <td>Approx. 5</td> </tr> <tr> <td rowspan="2">Front RH door switch</td> <td rowspan="2">40</td> <td rowspan="2">ground</td> <td>Open</td> <td>0</td> </tr> <tr> <td>Closed</td> <td>Approx. 5</td> </tr> <tr> <td rowspan="2">Rear and back door switches</td> <td rowspan="2">28</td> <td rowspan="2">ground</td> <td>Open</td> <td>0</td> </tr> <tr> <td>Closed</td> <td>Approx. 5</td> </tr> </tbody> </table> <p style="text-align: right; margin-top: 5px;">SEL305X</p> <p>Refer to wiring diagram in EL-275.</p> <p style="text-align: center; margin-top: 10px;">OK or NG</p> <table border="1" style="width: 100%; border-collapse: collapse; margin-top: 5px;"> <tr> <td style="width: 20%;">OK</td> <td style="width: 5%; text-align: center;">▶</td> <td>Door switch is OK.</td> </tr> <tr> <td>NG</td> <td style="text-align: center;">▶</td> <td>GO TO 2.</td> </tr> </table>				Terminals		Condition	Voltage [V]	(+)	(-)	Front LH door switch	29	ground	Open	0	Closed	Approx. 5	Front RH door switch	40	ground	Open	0	Closed	Approx. 5	Rear and back door switches	28	ground	Open	0	Closed	Approx. 5	OK	▶	Door switch is OK.	NG	▶	GO TO 2.
	Terminals		Condition	Voltage [V]																																		
	(+)	(-)																																				
Front LH door switch	29	ground	Open	0																																		
			Closed	Approx. 5																																		
Front RH door switch	40	ground	Open	0																																		
			Closed	Approx. 5																																		
Rear and back door switches	28	ground	Open	0																																		
			Closed	Approx. 5																																		
OK	▶	Door switch is OK.																																				
NG	▶	GO TO 2.																																				

2	CHECK DOOR SWITCH	<p>1. Disconnect door switch connector. 2. Check continuity between door switch terminals.</p> <div style="display: flex; justify-content: space-around; align-items: flex-start;"> <div style="text-align: center;"> <p>T.S. DISCONNECT</p> </div> <div style="text-align: center;"> <p>T.S. DISCONNECT</p> </div> <div style="text-align: center;"> <p>T.S. DISCONNECT</p> </div> </div> <div style="display: flex; justify-content: space-around; margin-top: 10px;"> <div style="text-align: center;"> <p>Door switch connector Front LH (B9)</p> </div> <div style="text-align: center;"> <p>Back door switch (D208)</p> </div> <div style="text-align: center;"> <p>Door switch connector Front RH : (B68) Rear LH : (B18) Rear RH : (B71)</p> </div> </div> <table border="1" style="margin-top: 10px; border-collapse: collapse; width: 100%;"> <thead> <tr> <th></th> <th>Terminals</th> <th>Condition</th> <th>Continuity</th> </tr> </thead> <tbody> <tr> <td rowspan="2">Front LH door switch</td> <td rowspan="2">1 - 2</td> <td>Closed</td> <td>No</td> </tr> <tr> <td>Open</td> <td>Yes</td> </tr> <tr> <td rowspan="2">Back door switch</td> <td rowspan="2">1 - 2</td> <td>Closed</td> <td>No</td> </tr> <tr> <td>Open</td> <td>Yes</td> </tr> <tr> <td rowspan="2">Front RH and rear door switches</td> <td rowspan="2">1 - ground</td> <td>Closed</td> <td>No</td> </tr> <tr> <td>Open</td> <td>Yes</td> </tr> </tbody> </table> <p style="text-align: right; margin-top: 5px;">SEL306X</p> <p style="text-align: center; margin-top: 10px;">OK or NG</p> <table border="1" style="width: 100%; border-collapse: collapse; margin-top: 5px;"> <tr> <td style="width: 20%;">OK</td> <td style="width: 5%; text-align: center;">▶</td> <td> <p>Check the following.</p> <ul style="list-style-type: none"> ● Door switch ground circuit (Front, back door) or door switch ground condition ● Harness for open or short between smart entrance control unit and door switch </td> </tr> <tr> <td>NG</td> <td style="text-align: center;">▶</td> <td>Replace door switch.</td> </tr> </table>				Terminals	Condition	Continuity	Front LH door switch	1 - 2	Closed	No	Open	Yes	Back door switch	1 - 2	Closed	No	Open	Yes	Front RH and rear door switches	1 - ground	Closed	No	Open	Yes	OK	▶	<p>Check the following.</p> <ul style="list-style-type: none"> ● Door switch ground circuit (Front, back door) or door switch ground condition ● Harness for open or short between smart entrance control unit and door switch 	NG	▶	Replace door switch.
	Terminals	Condition	Continuity																													
Front LH door switch	1 - 2	Closed	No																													
		Open	Yes																													
Back door switch	1 - 2	Closed	No																													
		Open	Yes																													
Front RH and rear door switches	1 - ground	Closed	No																													
		Open	Yes																													
OK	▶	<p>Check the following.</p> <ul style="list-style-type: none"> ● Door switch ground circuit (Front, back door) or door switch ground condition ● Harness for open or short between smart entrance control unit and door switch 																														
NG	▶	Replace door switch.																														



GI
MA
EM
LC
EC
FE
AT
TF
PD
AX
SU
BR
ST
RS
BT
HA
SC
EL
IDX



MULTI-REMOTE CONTROL SYSTEM

Trouble Diagnoses (Cont'd)

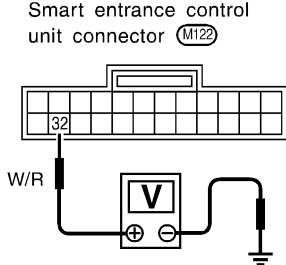
KEY SWITCH (INSERT) CHECK

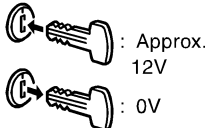
=NBEL0115S07

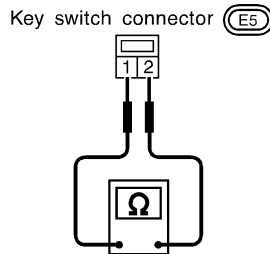
1	CHECK KEY SWITCH INPUT SIGNAL	
<p>Check voltage between smart entrance control unit terminal 32 and ground.</p>		
<div style="display: flex; justify-content: space-between; align-items: flex-start;"> <div style="width: 45%;"> <p>Smart entrance control unit connector (M122)</p>  <p>W/R</p> </div> <div style="width: 40%;"> <p>H.S. CONNECT</p>  <p>Approx. 12V</p> <p>0V</p>  </div> <div style="width: 45%;"> <p>Voltage [V]:</p> <p>Condition of key switch: Key is inserted. Approx. 12</p> <p>Condition of key switch: Key is removed. 0</p> </div> </div>		
SEL307X		
OK or NG		
OK	▶	Key switch is OK.
NG	▶	GO TO 2.

2	CHECK KEY SWITCH (INSERT)	
<p>Check continuity between terminals 1 and 2.</p>		
<div style="display: flex; justify-content: space-between; align-items: flex-start;"> <div style="width: 45%;"> <p>Key switch connector (E5)</p>  </div> <div style="width: 40%;"> <p>T.S. DISCONNECT</p>   </div> <div style="width: 45%;"> <p>Continuity:</p> <p>Condition of key switch: Key is inserted. Yes</p> <p>Condition of key switch: Key is removed. No</p> </div> </div>		
SEL308X		
OK or NG		
OK	▶	<p>Check the following.</p> <ul style="list-style-type: none"> ● 7.5A fuse [No. 24, located in fuse block (J/B)] ● Harness for open or short between key switch and fuse ● Harness for open or short between smart entrance control unit and key switch
NG	▶	Replace key switch.

MULTI-REMOTE CONTROL SYSTEM

Trouble Diagnoses (Cont'd)

DOOR LOCK/UNLOCK SWITCH LH CHECK

=NBEL0115S10

1 CHECK DOOR LOCK/UNLOCK SWITCH INPUT SIGNAL

1. Disconnect smart entrance control unit connector.
2. Check continuity between control unit terminal 23 or 35 and ground.

Smart entrance control unit connector (M122)

BR LG/R

DISCONNECT H.S. OFF

Terminals	Door lock/unlock switch (LH or RH) condition	Continuity
23 - ground	Lock	Yes
	N and Unlock	No
35 - ground	Unlock	Yes
	N and Lock	No

Refer to wiring diagram in EL-274.

SEL309X

OK or NG

OK	▶	Door lock/unlock switch is OK.
NG	▶	GO TO 2.

2 CHECK DOOR LOCK/UNLOCK SWITCH

1. Disconnect door lock/unlock switch connector.
2. Check continuity between each door lock/unlock switch terminals.
 - Power window main switch (Door lock/unlock switch LH)

P/W main switch connector

DISCONNECT T.S.

5 6 19 15

D6 D15

Condition	Terminals		
	5	19	6
Lock	○	○	○
N	No continuity		
Unlock	○	○	○

SEL310X

OK or NG

OK	▶	<p>Check the following.</p> <ul style="list-style-type: none"> ● Ground circuit for door lock/unlock switch ● Harness for open or short between door lock/unlock switch and smart entrance control unit connector
NG	▶	Replace door lock/unlock switch.

GI
MA
EM
LC
EC
FE
AT
TF
PD
AX
SU
BR
ST
RS
BT
HA
SC
EL
IDX

MULTI-REMOTE CONTROL SYSTEM

Trouble Diagnoses (Cont'd)

FRONT LH DOOR UNLOCK SENSOR CHECK

=NBEL0115S06

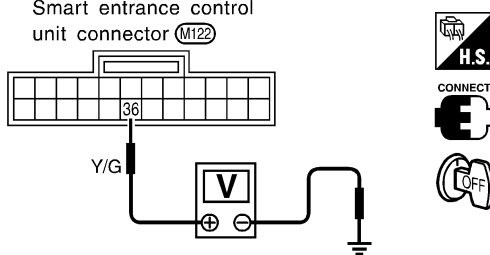
1	CHECK FRONT LH DOOR UNLOCK SENSOR INPUT SIGNAL		
<p>Check voltage between smart entrance control unit terminal 36 and ground.</p>			
			
SEL323X			
<p>Refer to wiring diagram in EL-275.</p>			
OK or NG			
OK	▶	Door unlock sensor is OK.	
NG	▶	GO TO 2.	

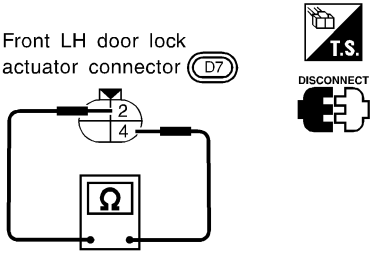
2	CHECK FRONT LH DOOR UNLOCK SENSOR		
<p>1. Disconnect front LH door unlock sensor connector. 2. Check continuity between door unlock sensor terminals.</p>			
			
SEL324X			
OK or NG			
OK	▶	<p>Check the following.</p> <ul style="list-style-type: none"> ● Door unlock sensor ground circuit ● Harness for open or short between smart entrance control unit and door unlock sensor 	
NG	▶	Replace door unlock sensor.	

MULTI-REMOTE CONTROL SYSTEM

Trouble Diagnoses (Cont'd)

HAZARD REMINDER CHECK

=NBEL0115S08

1	CHECK HAZARD INDICATOR	
Check if hazard indicator flashes with hazard switch.		
Does hazard indicator operate?		
Yes	▶	GO TO 2.
No	▶	Check "hazard indicator" circuit.

GI
MA
EM

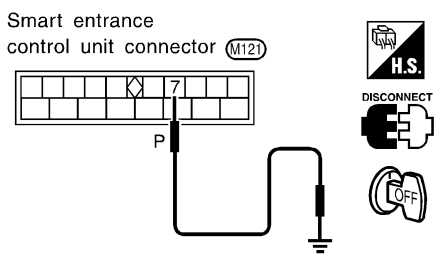
2	CHECK HAZARD REMINDER OPERATION	
<p>1. Disconnect smart entrance control unit connector. 2. Apply ground to control unit terminal 7.</p>		
		
Hazard indicator illuminate.		
Refer to wiring diagram in EL-276.		
OK or NG		
OK	▶	Replace smart entrance control unit.
NG	▶	GO TO 3.

LC
EC
FE
AT
TF
PD

SEL325X

AX

3	CHECK MULTI-REMOTE CONTROL RELAY	
Check multi-remote control relay.		
OK or NG		
OK	▶	GO TO 4.
NG	▶	Replace.

SU
BR
ST

RS

BT

HA

SC

EL

IDX

MULTI-REMOTE CONTROL SYSTEM

Trouble Diagnoses (Cont'd)

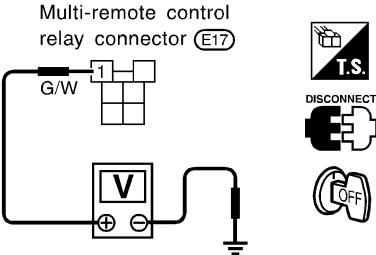
4	CHECK POWER SUPPLY FOR MULTI-REMOTE CONTROL RELAY	
<p>1. Disconnect multi-remote control relay connector. 2. Check voltage between terminal 1 and ground.</p>		
		
Battery voltage should exist.		
SEL326X		
OK or NG		
OK	▶	GO TO 5.
NG	▶	<p>Check the following.</p> <ul style="list-style-type: none"> ● 15A fuse [No. 20, located in fuse block (J/B)] ● Harness for open or short between multi-remote control relay and fuse

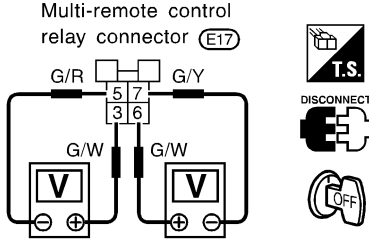
5	CHECK MULTI-REMOTE CONTROL RELAY CIRCUIT	
<p>1. Disconnect multi-remote control relay connector. 2. Check voltage between terminals 3 and 5. 3. Check voltage between terminals 6 and 7.</p>		
		
Battery voltage should exist.		
SEL327X		
OK or NG		
OK	▶	Check harness for open or short between smart entrance control unit and multi-remote control relay.
NG	▶	<p>Check the following.</p> <ul style="list-style-type: none"> ● Harness for open or short between multi-remote control relay and fuse ● Harness for open or short between multi-remote control relay and turn signal lamps

MULTI-REMOTE CONTROL SYSTEM

Trouble Diagnoses (Cont'd)

HORN REMINDER CHECK

=NBEL0115S11

1	CHECK HORN	
Check if horn sounds with horn switch.		
Does horn operate?		
Yes	▶	GO TO 2.
No	▶	Check horn circuit.

GI
MA
EM

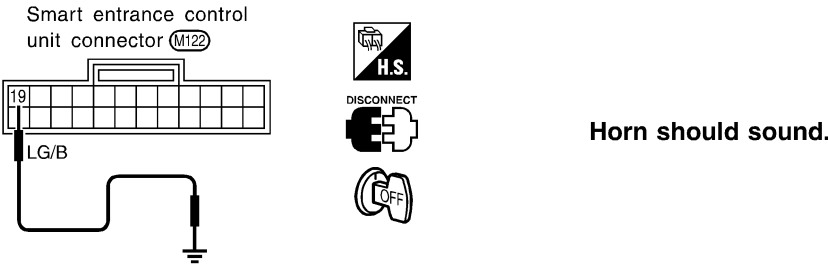
2	CHECK HORN REMINDER OPERATION	
<p>1. Disconnect smart entrance control unit connector.</p> <p>2. Apply ground to smart entrance control unit terminal 19.</p>		
		
<p>Refer to wiring diagram in EL-276.</p> <p style="text-align: right;">SEL328X</p>		
OK or NG		
OK	▶	Replace smart entrance control unit.
NG	▶	Check harness for open or short between smart entrance control unit and horn relay.

LC
EC
FE
AT
TF
PD

AX

SU

BR

ST

RS

BT

HA

SC

EL

IDX

MULTI-REMOTE CONTROL SYSTEM

Trouble Diagnoses (Cont'd)

INTERIOR ROOM LAMP OPERATION CHECK

=NBEL0115S09

1	CHECK INTERIOR ROOM LAMP
Check if the interior room lamp switch is in the "ON" position and the lamp illuminates.	
Does interior room lamp illuminate?	
Yes	▶ GO TO 2.
No	▶ Check the following. <ul style="list-style-type: none"> ● Harness for open or short between smart entrance control unit and interior room lamp ● Interior room lamp

2	CHECK INTERIOR ROOM LAMP CIRCUIT
When interior room lamp switch is "DOOR" position, check voltage across smart entrance control unit terminal 8 and ground.	
Battery voltage should exist.	
SEL329X	
OK or NG	
OK	▶ GO TO 3.
NG	▶ Repair harness between smart entrance control unit and interior room lamp.

3	CHECK CONTROL UNIT OUTPUT
Push unlock button of remote controller with key removed and all doors closed, and check voltage across smart entrance control unit terminal 8 and ground.	
Voltage [V]: Unlock button is pushed. 0 (For approx. 30 seconds.) Unlock button is not pushed. Battery voltage	
SEL330X	
OK or NG	
OK	▶ Check system again.
NG	▶ Replace smart entrance control unit.

ID Code Entry Procedure

REMOTE CONTROLLER ID SET UP WITH CONSULT-II

=NBEL0222
NBEL0222S01

NOTE:

If a remote controller is lost, the ID code of the lost remote controller must be erased to prevent unauthorized use. When the ID code of a lost remote controller is not known, all controller ID codes should be erased. After all ID codes are erased, the ID codes of all remaining and/or new remote controllers must be re-registered.

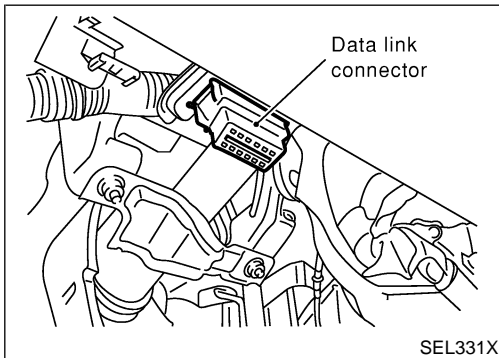

1. Turn ignition switch "OFF".
2. Connect CONSULT-II to the data link connector.

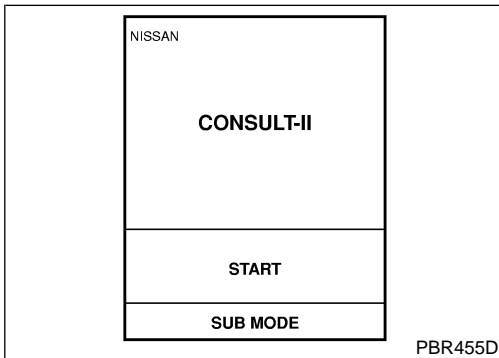

3. Turn ignition switch "ON".
4. Touch "START".

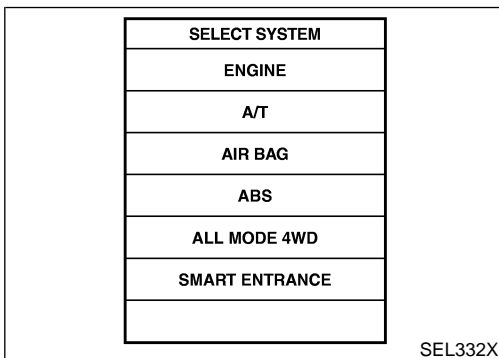

5. Touch "SMART ENTRANCE".

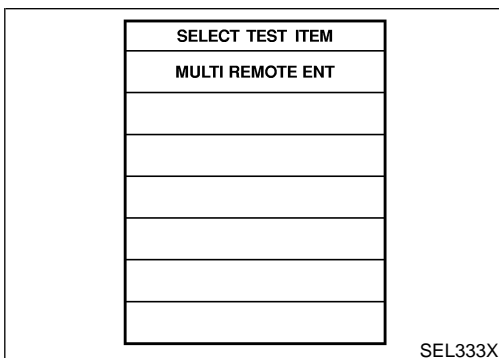

6. Touch "MULTI REMOTE ENT".

GI

MA

EM

LC

EC

FE

AT

TF

PD

AX

SU

BR

ST

RS

BT

HA

SC

EL

IDX

MULTI-REMOTE CONTROL SYSTEM

ID Code Entry Procedure (Cont'd)

SELECT DIAG MODE
WORK SUPPORT

SEL334X

7. Touch "WORK SUPPORT".

SELECT WORK ITEM
REMO CONT ID CONFIR
REMO CONT ID REGIST
REMO CONT ID ERASUR

SEL335X

8. The items are shown on the figure at left can be set up.

- "REMO CONT ID CONFIR"
Use this mode to confirm if a remote controller ID code is registered or not.
- "REMO CONT ID REGIST"
Use this mode to register a remote controller ID code.

NOTE:

Register the ID code when remote controller or smart entrance control unit is replaced, or when additional remote controller is required.

- "REMO CONT ID ERASUR"
Use this mode to erase a remote controller ID code.

MULTI-REMOTE CONTROL SYSTEM

ID Code Entry Procedure (Cont'd)

REMOTE CONTROLLER ID SET UP WITHOUT CONSULT-II

NBEL0222S03

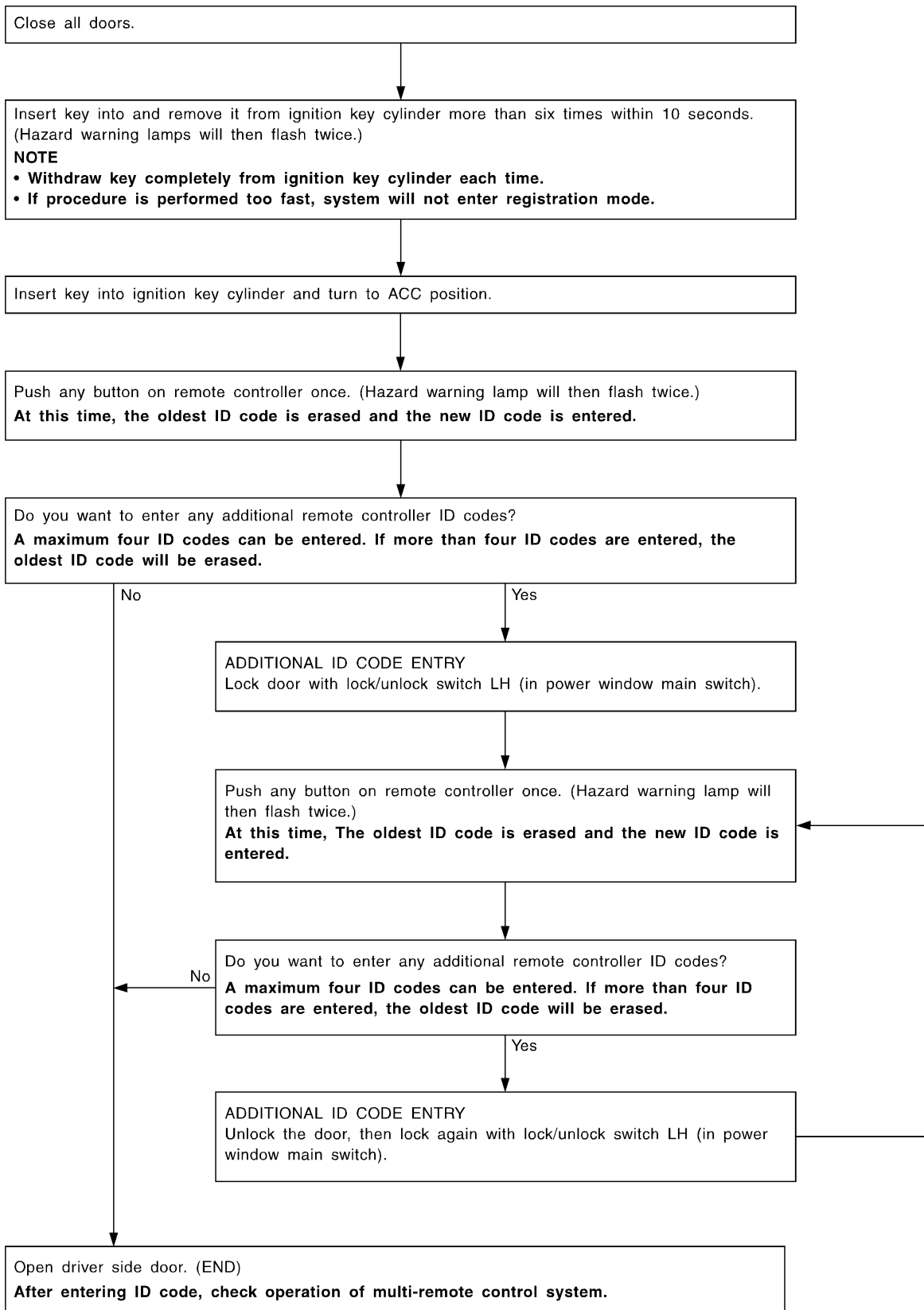

GI
MA
EM
LC
EC
FE
AT
TF
PD
AX
SU
BR
ST
RS
BT
HA
SC
EL
IDX

SEL332WA

MULTI-REMOTE CONTROL SYSTEM

ID Code Entry Procedure (Cont'd)

NOTE:

- If a remote controller is lost, the ID code of the lost remote controller must be erased to prevent unauthorized use. A specific ID code can be erased with CONSULT-II. However, when the ID code of a lost remote controller is not known, all controller ID codes should be erased. After all ID codes are erased, the ID codes of all remaining and/or new remote controllers must be re-registered.
To erase all ID codes in memory, register one ID code (remote controller) four times. After all ID codes are erased, the ID codes of all remaining and/or new remote controllers must be re-registered.
- When registering an additional remote controller, the existing ID codes in memory may or may not be erased. If four ID codes are stored in memory, when an additional code is registered, only the oldest code is erased. If less than four ID codes are stored in memory, when an additional ID code is registered, the new ID code is added and no ID codes are erased.
- If you need to activate more than two additional new remote controllers, repeat the procedure "Additional ID code entry" for each new remote controller.
- Entry of maximum four ID codes is allowed. When more than four ID codes are entered, the oldest ID code will be erased.
- Even if the same ID code that is already in the memory is input, the same ID code can be entered. The code is counted as an additional code.

MULTI-REMOTE CONTROL SYSTEM

Remote Controller Battery Replacement

Remote Controller Battery Replacement

NBEL0118

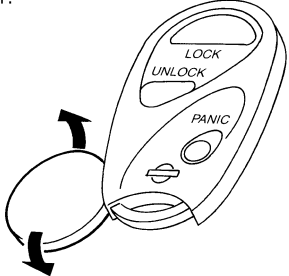
- 

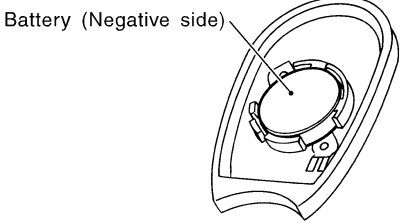
1. Open the lid using a coin.
- 

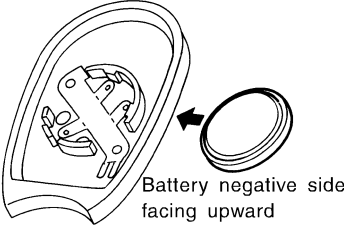
2. Battery (Negative side)
Remove the battery.
- 

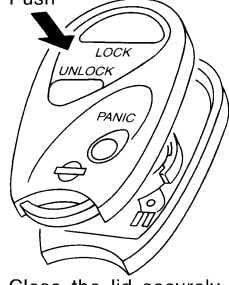
3. Insert the new battery.
Battery negative side facing upward
- 

4. Push
Close the lid securely.
Push the remote controller button two or three times to check its operation.

NOTE:

- Be careful not to touch the circuit board or battery terminal.
- The remote controller is water-resistant. However, if it does get wet, immediately wipe it dry.

SEL732W

GI

MA

EM

LC

EC

FE

AT

TF

PD

AX

SU

BR

ST

RS

BT

HA

SC

EL

IDX

THEFT WARNING SYSTEM

Component Parts and Harness Connector Location

Component Parts and Harness Connector Location

NBEL0119

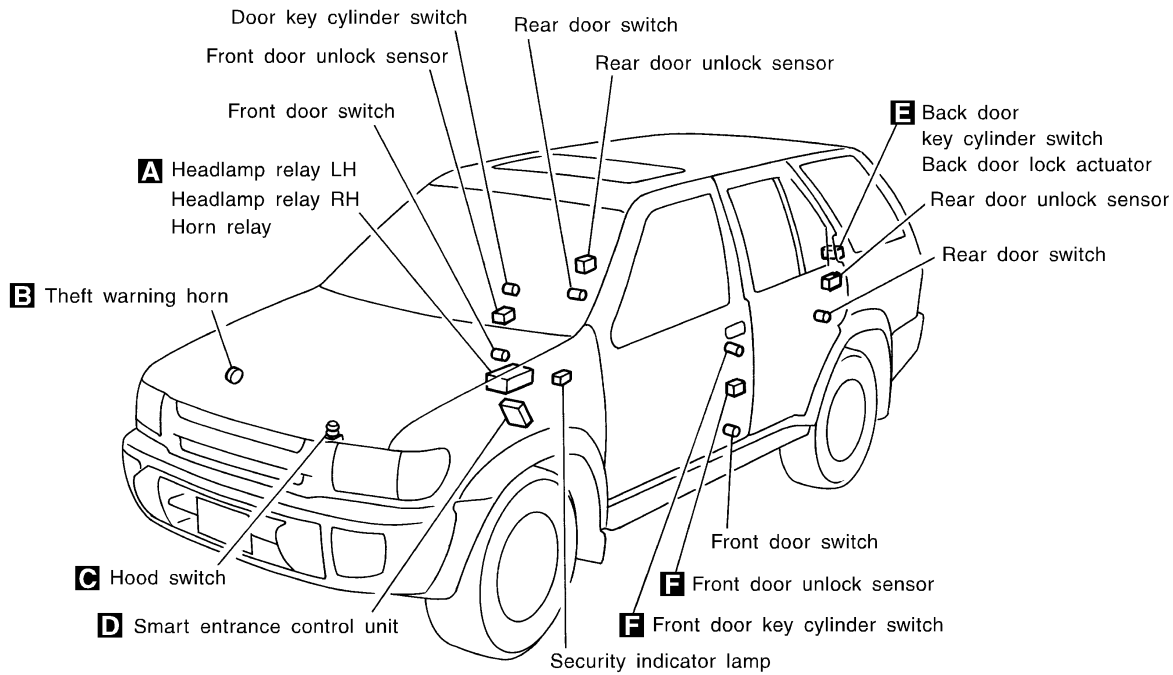

<p>Fuse block (J/B)</p> <table border="1"> <tr><td>1</td><td>2</td><td>3</td><td>4</td><td>5</td></tr> <tr><td>6</td><td>7</td><td>8</td><td>9</td><td>10</td></tr> <tr><td>11</td><td>12</td><td>13</td><td>14</td><td>15</td></tr> <tr><td>16</td><td>17</td><td>18</td><td>19</td><td>20</td></tr> <tr><td>21</td><td>22</td><td>23</td><td></td><td></td></tr> <tr><td>24</td><td>25</td><td>26</td><td></td><td></td></tr> <tr><td>27</td><td>28</td><td>29</td><td></td><td></td></tr> </table>	1	2	3	4	5	6	7	8	9	10	11	12	13	14	15	16	17	18	19	20	21	22	23			24	25	26			27	28	29			<p>Front ↑</p> <p>Fuse and fusible link box</p> <table border="1"> <tr><td>51</td><td>52</td><td>53</td><td>54</td><td>55</td><td>56</td><td>57</td><td>58</td><td>a</td><td>f</td><td>g</td><td>h</td><td>i</td></tr> <tr><td>b</td><td>c</td><td>d</td><td>e</td><td></td><td></td><td></td><td></td><td></td><td>59</td><td>60</td><td>61</td><td>62</td><td>63</td><td>64</td><td>65</td><td>66</td></tr> </table>	51	52	53	54	55	56	57	58	a	f	g	h	i	b	c	d	e						59	60	61	62	63	64	65	66	<p>A Horn relay (E118) Headlamp relay LH (E98) Headlamp relay RH (E97)</p>
1	2	3	4	5																																																															
6	7	8	9	10																																																															
11	12	13	14	15																																																															
16	17	18	19	20																																																															
21	22	23																																																																	
24	25	26																																																																	
27	28	29																																																																	
51	52	53	54	55	56	57	58	a	f	g	h	i																																																							
b	c	d	e						59	60	61	62	63	64	65	66																																																			
<p>B Horn (HIGH) (E50)</p>	<p>C Hood switch (E31)</p>	<p>F Front door key cylinder switch (D9)</p>																																																																	
<p>D Behind instrument lower panel, driver side Smart entrance control unit (M121) (M122)</p>	<p>E Back door key cylinder switch (D201) Back door lock actuator (D207) Glass hatch switch (D209)</p>	<p>Front door unlock sensor (D7)</p>																																																																	

SEL356X

System Description

DESCRIPTION

NBEL0120

1. Operation Flow

NBEL0120S01

NBEL0120S0101

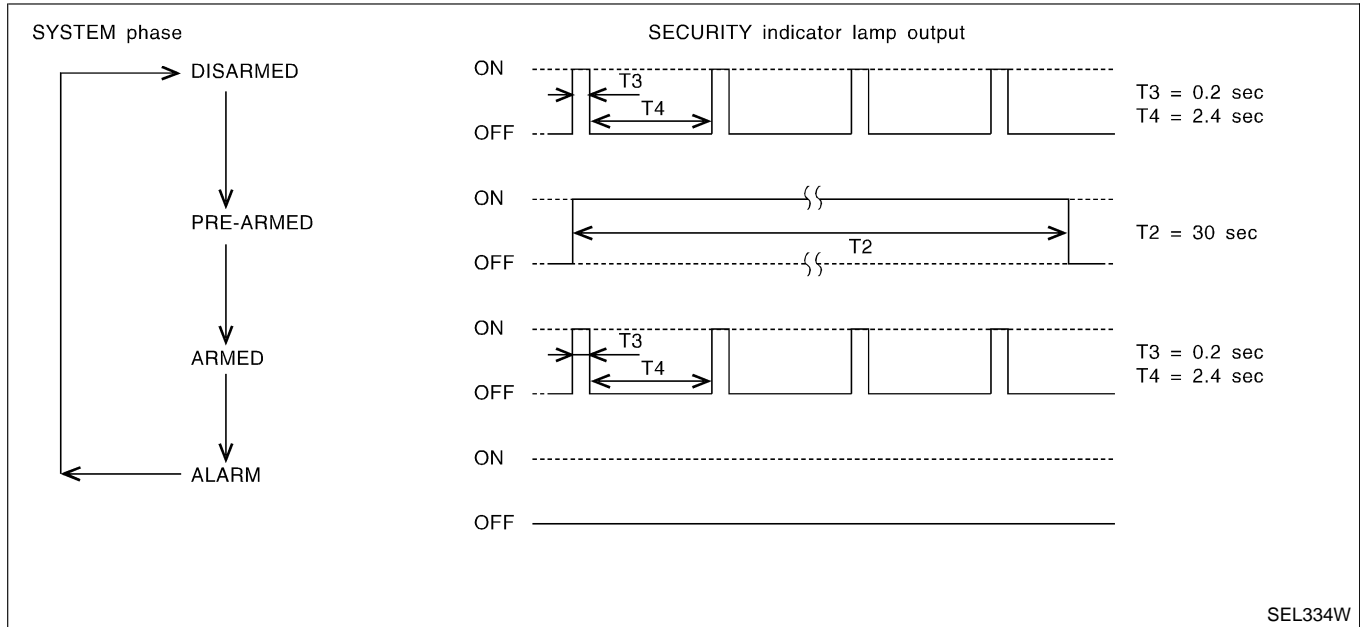

SEL334W

2. Setting The Theft Warning System

NBEL0120S0102

Initial condition

- 1) Close all doors.
- 2) Close hood and glass hatch.

Disarmed phase

When the theft warning system is in the disarmed phase, the security indicator lamp blinks every 2.6 seconds.

Pre-armed phase and armed phase

The theft warning system turns into the "pre-armed" phase when hood, glass hatch and all doors are closed and the doors are locked by key or multi-remote controller. (The security indicator lamp illuminates.)

After about 30 seconds, the system automatically shifts into the "armed" phase (the system is set). (The security indicator lamp blinks every 2.6 seconds.)

3. Canceling The Set Theft Warning System

NBEL0120S0103

When the following 1) or 2) operation is performed, the armed phase is canceled.

- 1) Unlock the doors with the key or multi-remote controller.
- 2) Open the glass hatch with the key.

4. Activating The Alarm Operation of The Theft Warning System

NBEL0120S0104

Make sure the system is in the armed phase. (The security indicator lamp blinks every 2.6 seconds.)

When any of the following operations is performed, the system sounds the horns and flashes the headlamps for about 50 seconds.

- 1) Engine hood, glass hatch or any door is opened before unlocking door with key or multi-remote controller.
- 2) Door is unlocked without using key or multi-remote controller.
- 3) Disconnecting and connecting the battery connector before canceling armed phase.

POWER SUPPLY AND GROUND

NBEL0120S07

Power is supplied at all times

- through 7.5A fuse [No. 24, located in the fuse block (J/B)]
- to security indicator lamp terminal 1, and
- to smart entrance control unit terminal 10.

With the ignition switch in the ON or START position, power is supplied

- through 7.5A fuse [No. 11, located in the fuse block (J/B)]

GI

MA

EM

LC

EC

FE

AT

TF

PD

AX

SU

BR

ST

RS

BT

HA

SC

EL

IDX

THEFT WARNING SYSTEM

System Description (Cont'd)

- to smart entrance control unit terminal 33.

With the ignition switch in the ACC or ON position, power is supplied

- through 10A fuse [No. 10, located in the fuse block (J/B)]
- to smart entrance control unit terminal 21.

Ground is supplied

- to smart entrance control unit terminal 16
- through body grounds M77 and M111.

INITIAL CONDITION TO ACTIVATE THE SYSTEM

NBEL0120S02

The operation of the theft warning system is controlled by the doors, hood and glass hatch.

To activate the theft warning system, the smart entrance control unit must receive signals indicating the doors, hood and glass hatch are closed and the doors are locked.

When a door is open, smart entrance control unit terminal 28, 29 or 40 receives a ground signal from each door switch.

When a door is unlocked, smart entrance control unit terminal 26, 36 or 37 receives a ground signal from terminal 4 of each door unlock sensor or terminal 1 of back door unlock sensor.

When the hood is open, smart entrance control unit terminal 27 receives a ground signal

- from terminal 1 of the hood switch
- through body grounds E13 and E41.

When the glass hatch is open, smart entrance control unit terminal 38 receives a ground signal

- from terminal 1 of the glass hatch switch
- through body grounds D210, B11 and B22.

When the doors are locked with key or multi-remote controller and none of the described conditions exist, the theft warning system will automatically shift to armed mode.

THEFT WARNING SYSTEM ACTIVATION (WITH KEY OR REMOTE CONTROLLER USED TO LOCK DOORS)

NBEL0120S03

If the key is used to lock doors, terminal 41 receives a ground signal

- from terminal 3 of the key cylinder switch LH
- through back grounds M77 and M111
- from terminal 1 of the back door key cylinder switch
- through body grounds B11, B22 and D210.

If this signal or lock signal from remote controller is received by the smart entrance control unit, the theft warning system will activate automatically.

Once the theft warning system has been activated, smart entrance control unit terminal 31 supplies ground to terminal 2 of the security indicator lamp.

The security lamp will illuminate for approximately 30 seconds and then blink.

Now the theft warning system is in armed phase.

THEFT WARNING SYSTEM ALARM OPERATION

NBEL0120S04

The theft warning system is triggered by

- opening a door
- opening the hood or the glass hatch
- unlocking door without using the key or multi-remote controller.

Once the theft warning system is in armed phase, if the smart entrance control unit receives a ground signal at terminal 26, 36, 37 (door unlock sensor), 28, 29, 40 (door switch), 38 (glass hatch switch) or 27 (hood switch), the theft warning system will be triggered. The headlamps flash and the horn sounds intermittently.

Power is supplied at all times

- through 7.5A fuse (No. 52, located in fuse and fusible link box)
- to horn relay terminals 1 and 3.
- through 10A fuse (No. 54, located in fuse and fusible link box)
- to horn relay terminal 6.

When the theft warning system is triggered, ground is supplied intermittently

- from terminal 4 of the smart entrance control unit
- to headlamp relay LH and RH terminal 2 and
- from terminal 19 of the smart entrance control unit

THEFT WARNING SYSTEM

System Description (Cont'd)

- to horn relay terminal 2.

The headlamps flash and the horn sounds intermittently.

The alarm automatically turns off after 50 seconds but will reactivate if the vehicle is tampered with again.

GI

THEFT WARNING SYSTEM DEACTIVATION

To deactivate the theft warning system, a door, the back door or the glass hatch must be unlocked with the key or remote controller. ^{NBEL0120S05}

MA

When the key is used to unlock the door, smart entrance control unit terminal 30 receives a ground signal

- from terminal 1 of the LH key cylinder switch
- from terminal 2 of the back door key cylinder switch.

EM

When the key is used to open the glass hatch, smart entrance control unit terminal 42 receives a ground signal from terminal 3 of the back door key cylinder switch. ^{NBEL0120S06}

LC

When the smart entrance control unit receives either one of these signals or unlock signal from remote controller, the theft warning system is deactivated. (Disarmed phase)

EC

PANIC ALARM OPERATION

Multi-remote control system may or may not operate theft warning system (horn and headlamps) as required. ^{NBEL0120S06}

FE

When the multi-remote control system is triggered, ground is supplied intermittently.

- from smart entrance control unit terminal 4
- to headlamp relay LH and RH terminal 2 and
- from terminal 19 of the smart entrance control unit
- to horn relay terminal 2.

AT

The headlamp flashes and the horn sounds intermittently.

TF

The alarm automatically turns off after 30 seconds or when smart entrance control unit receives any signal from multi-remote controller.

PD

AX

SU

BR

ST

RS

BT

HA

SC

EL

IDX

THEFT WARNING SYSTEM

Schematic

Schematic

NBEL0121

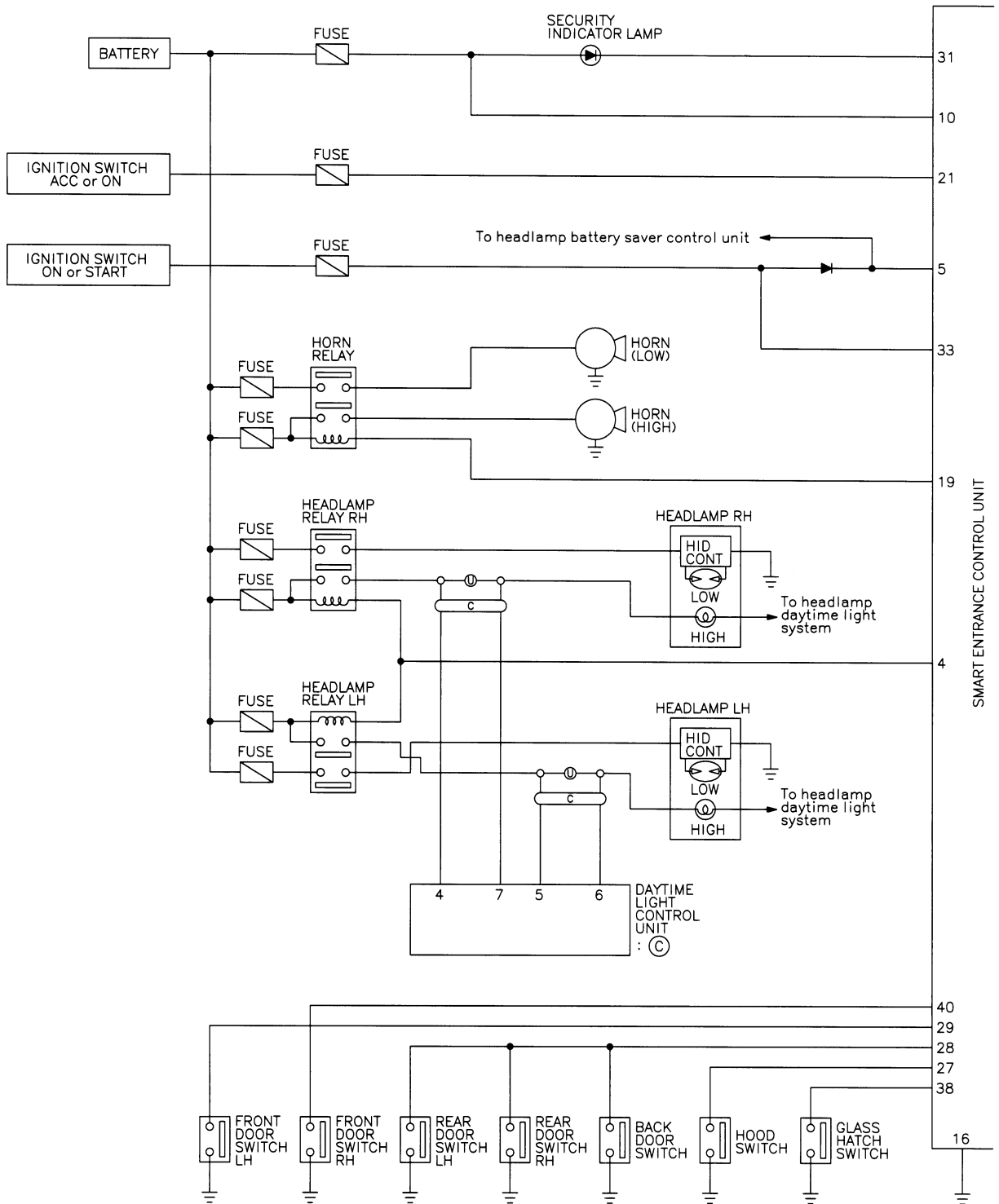

MEL857L

THEFT WARNING SYSTEM

Schematic (Cont'd)

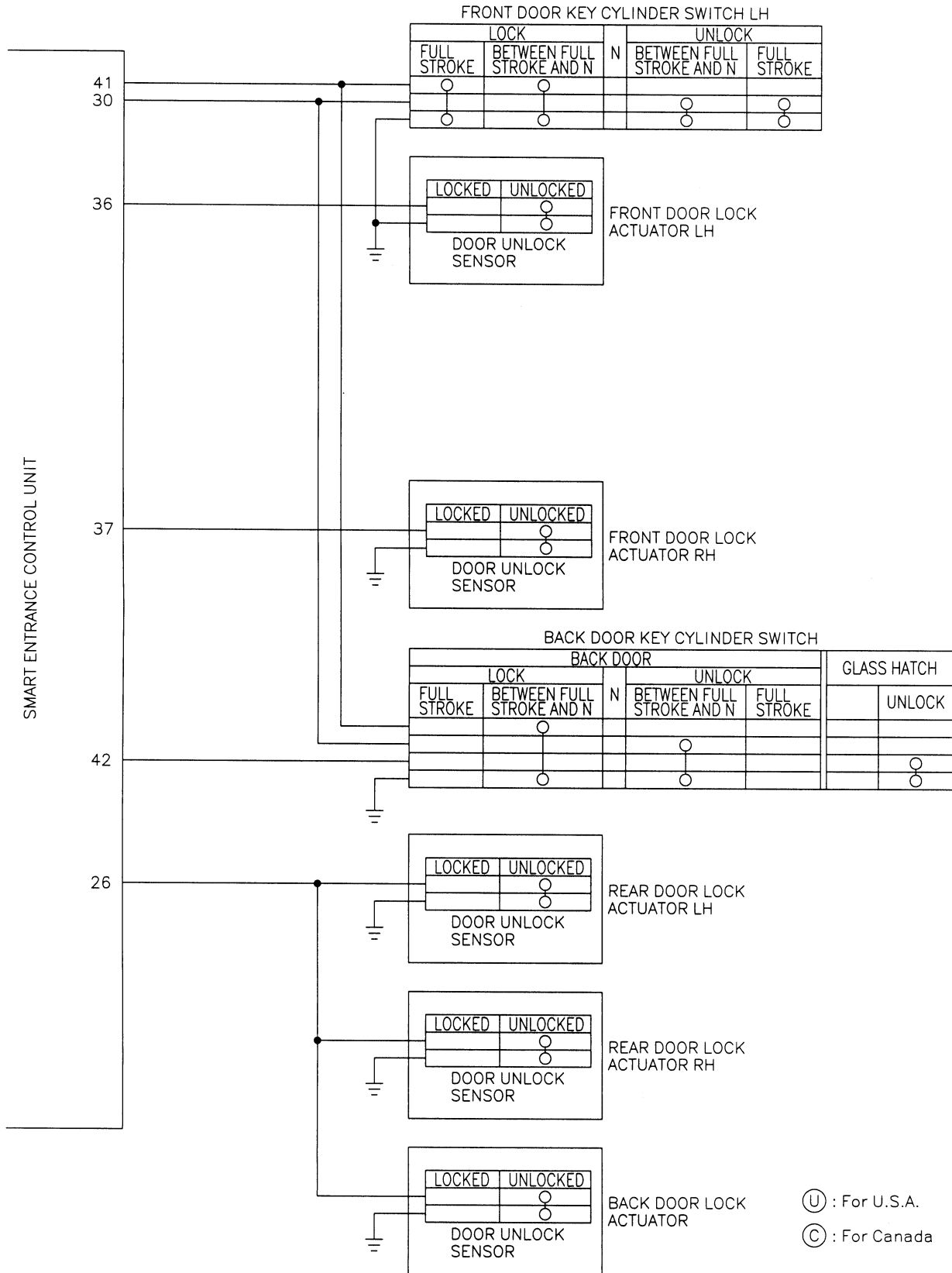

GI

MA

EM

LC

EC

FE

AT

TF

PD

AX

SU

BR

ST

RS

BT

HA

SC

EL

IDX

MEL263M

THEFT WARNING SYSTEM

Wiring Diagram — THEFT —

Wiring Diagram — THEFT —

NBEL0122

NBEL0122S01

FIG. 1

EL-THEFT-01

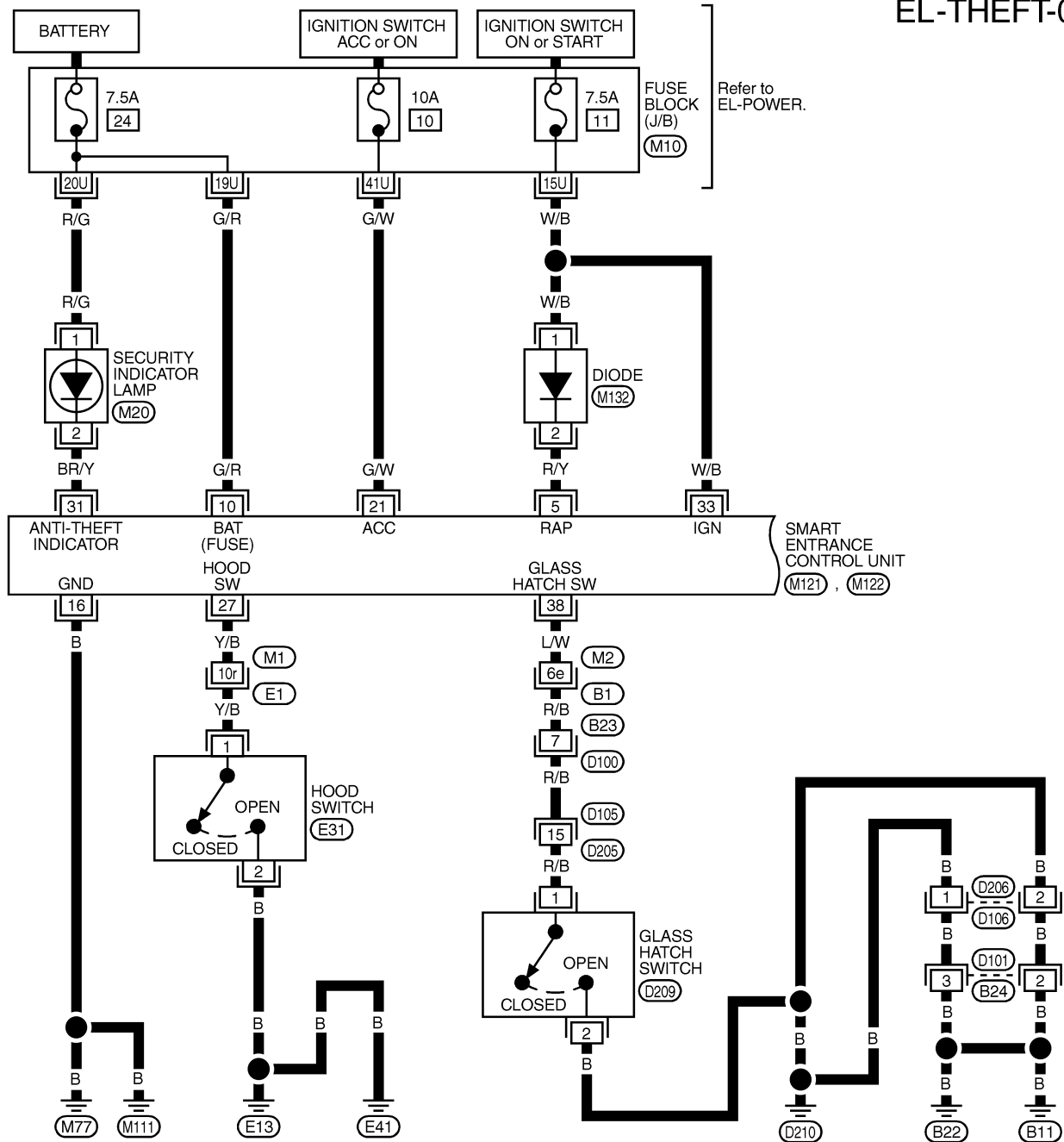

Refer to EL-POWER.

SMART ENTRANCE CONTROL UNIT (M121, M122)

REFER TO THE FOLLOWING.
 (E1), (B1) -SUPER MULTIPLE JUNCTION (SMJ)
 (M10) -FUSE BLOCK-JUNCTION BOX (J/B)

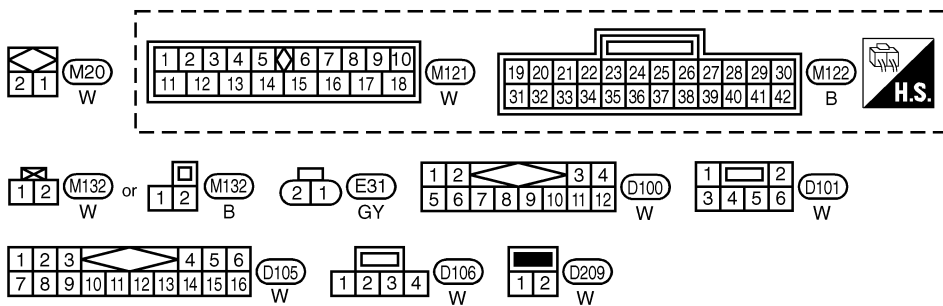

MEL0090

THEFT WARNING SYSTEM

Wiring Diagram — THEFT — (Cont'd)

FIG. 2

NBEL0122S02

EL-THEFT-02

GI
MA
EM
LC
EC
FE
AT
TF
PD
AX
SU
BR
ST
RS
BT
HA
SC
EL
IDX

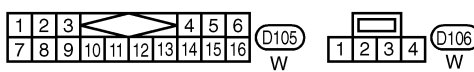
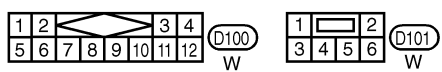
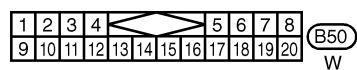
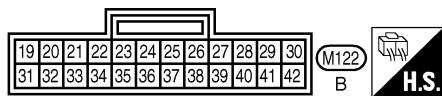
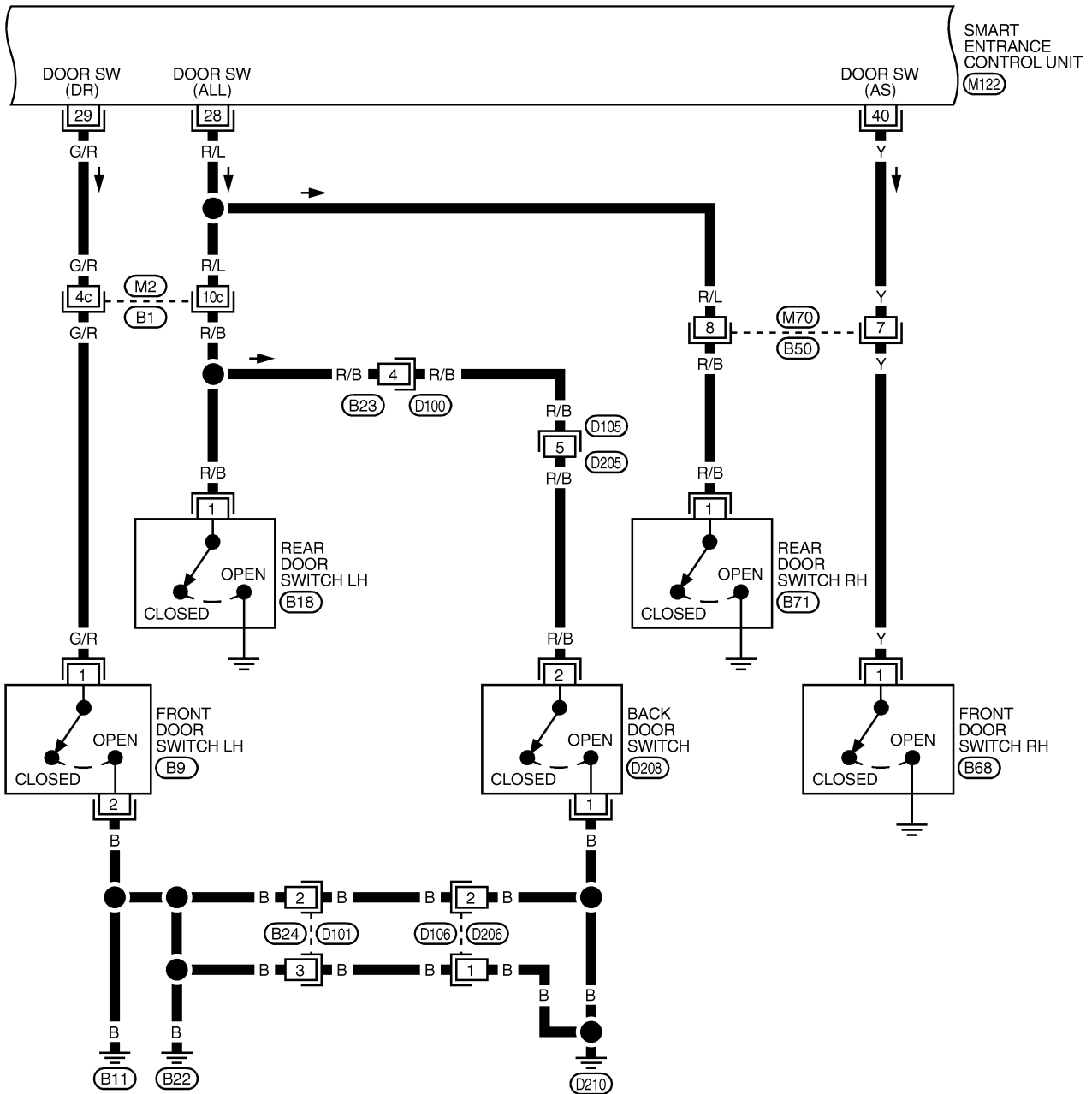

REFER TO THE FOLLOWING.
 (B1) - SUPER MULTIPLE JUNCTION (SMJ)

MEL859L

THEFT WARNING SYSTEM

Wiring Diagram — THEFT — (Cont'd)

FIG. 3

NBEL0122S03

EL-THEFT-03

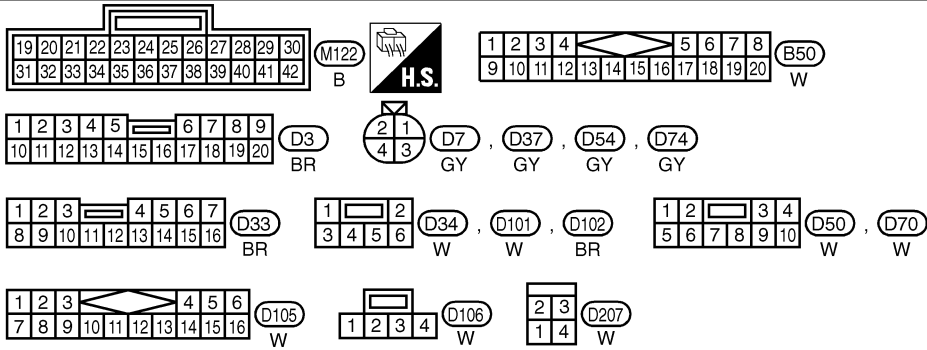
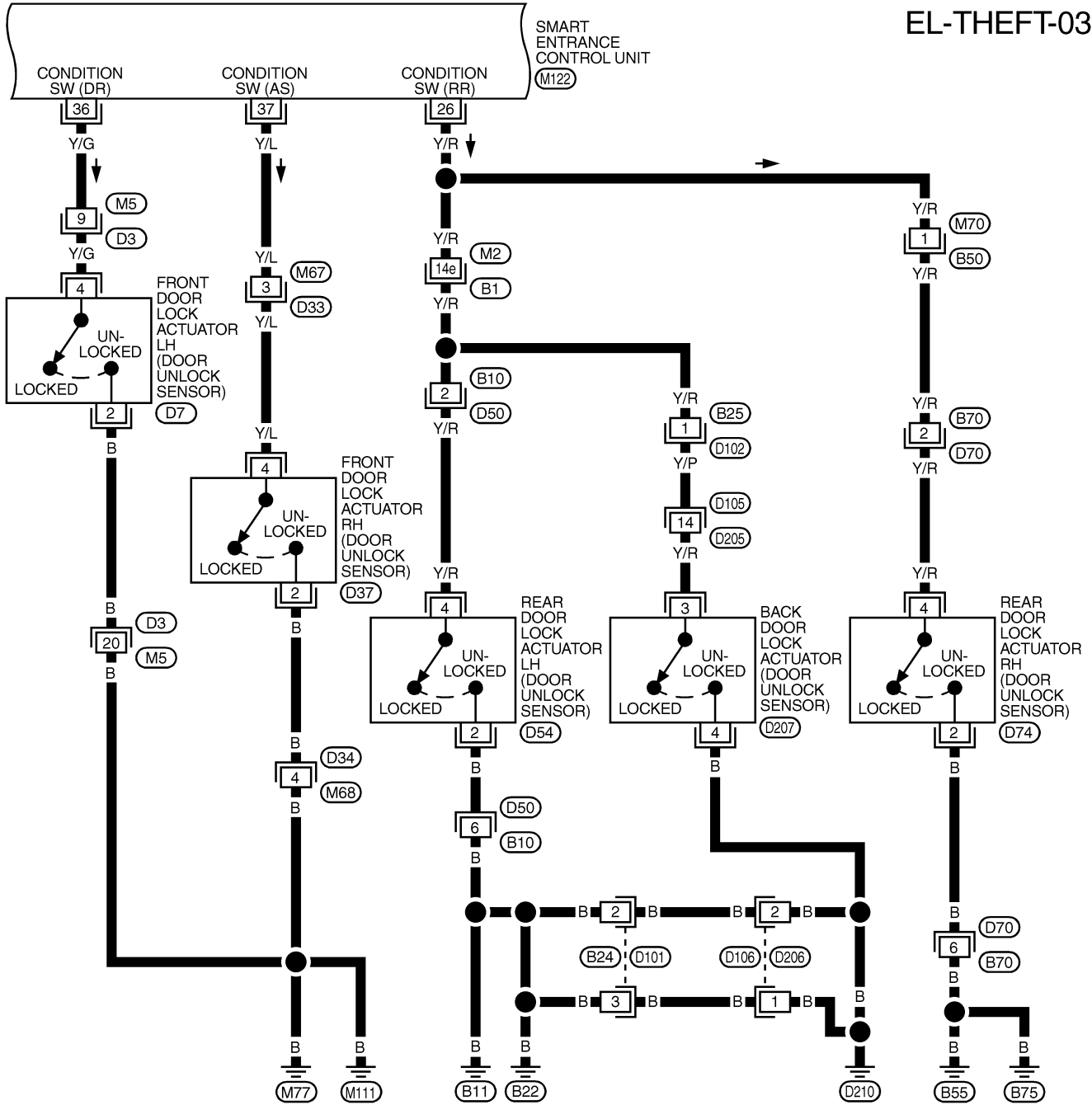

REFER TO THE FOLLOWING.

(B1) - SUPER MULTIPLE JUNCTION (SMJ)

THEFT WARNING SYSTEM

Wiring Diagram — THEFT — (Cont'd)

FIG. 4

NBEL0122S04

EL-THEFT-04

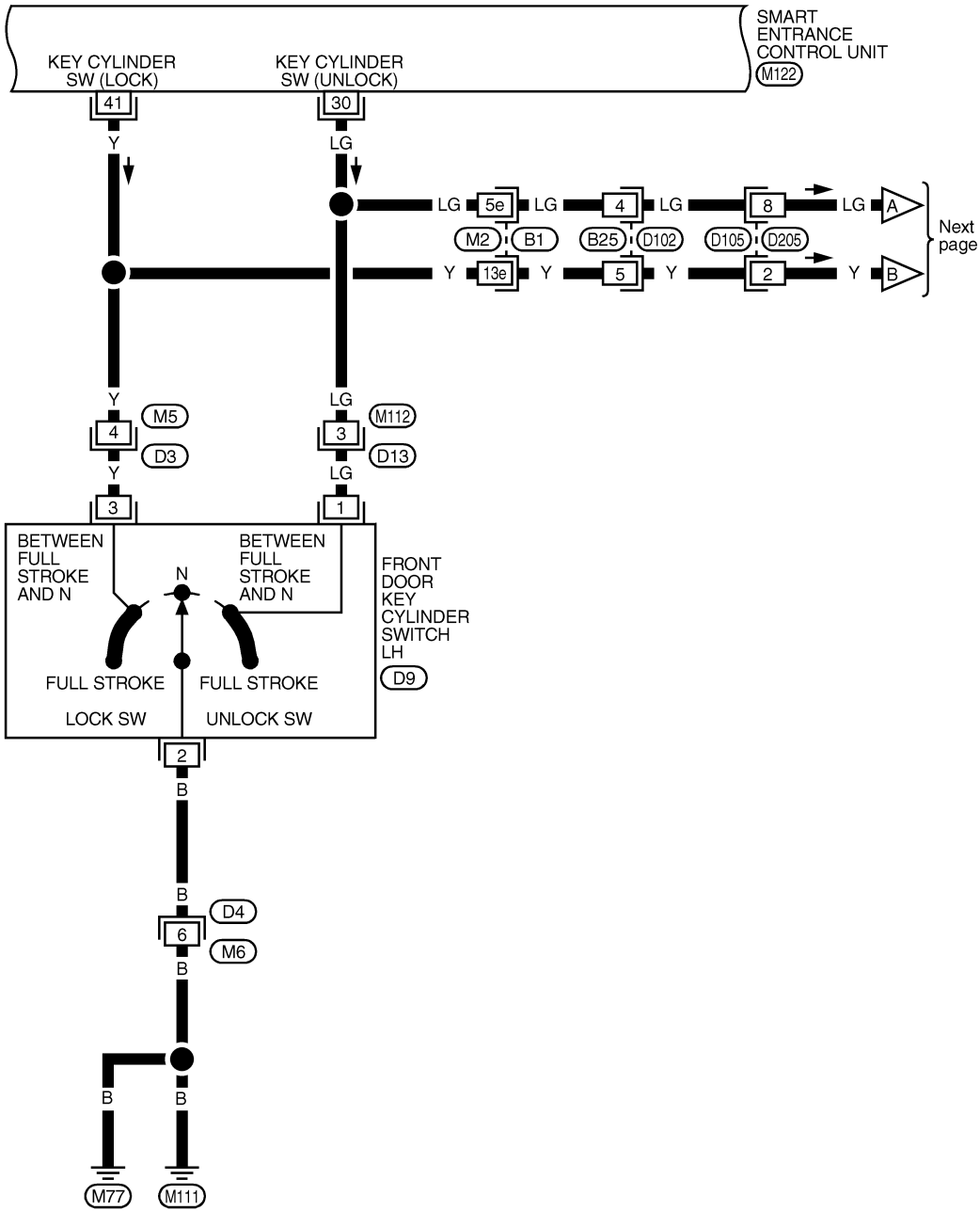

GI
MA
EM
LC
EC
FE
AT
TF
PD
AX
SU
BR
ST
RS
BT
HA
SC
EL
IDX

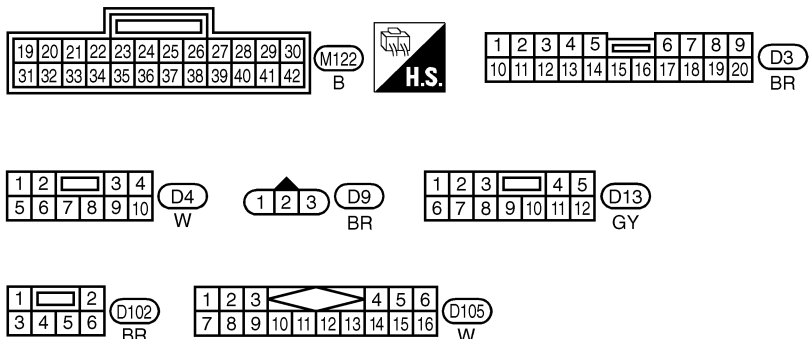

REFER TO THE FOLLOWING.

(B1) - SUPER MULTIPLE JUNCTION (SMJ)

MEL861L

THEFT WARNING SYSTEM

Wiring Diagram — THEFT — (Cont'd)

FIG. 5

NBEL0122S05

EL-THEFT-05

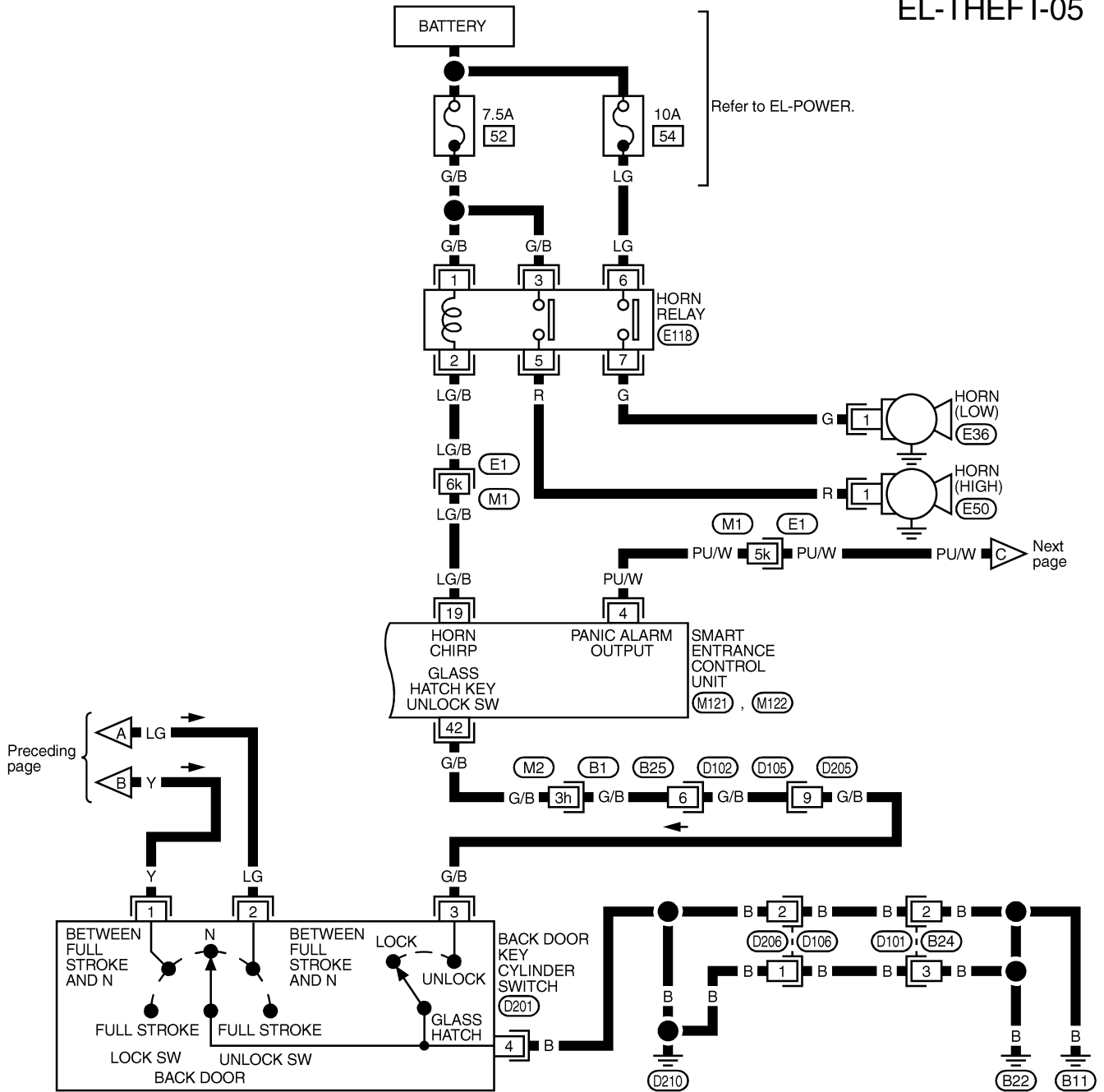

Preceding page

Next page

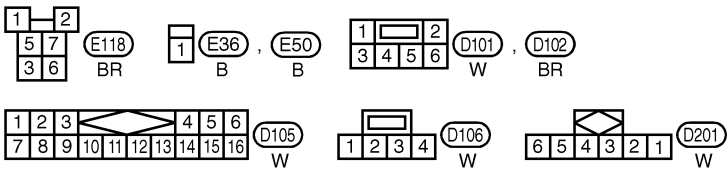
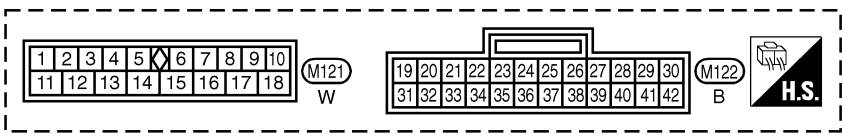

REFER TO THE FOLLOWING.
 (E1), (B1) -SUPER
 MULTIPLE JUNCTION (SMJ)

MEL862L

THEFT WARNING SYSTEM

Wiring Diagram — THEFT — (Cont'd)

FIG. 6

NBEL0122S06

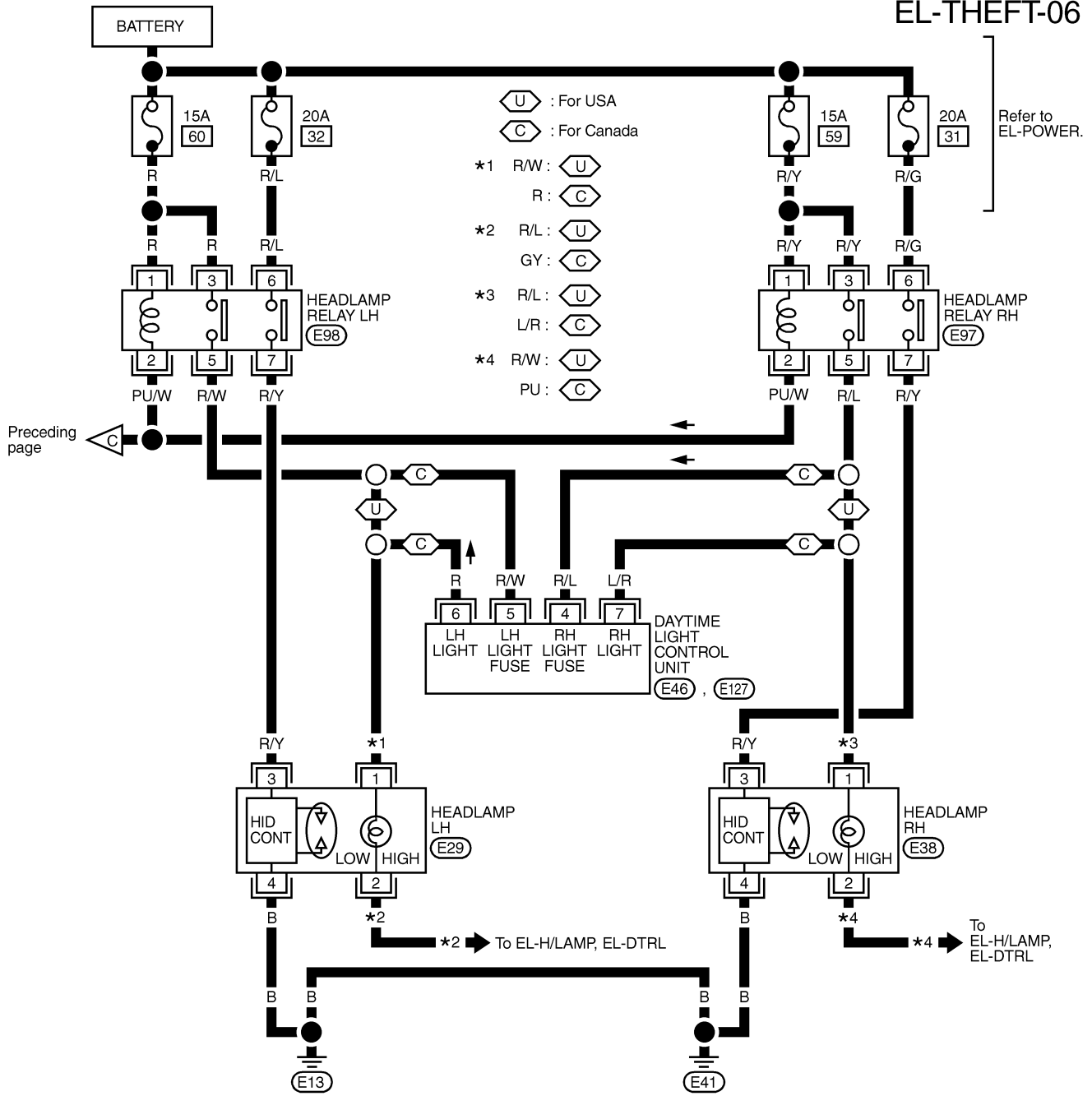

GI
MA
EM
LC
EC
FE
AT
TF
PD
AX
SU
BR
ST
RS
BT
HA
SC

EL

IDX

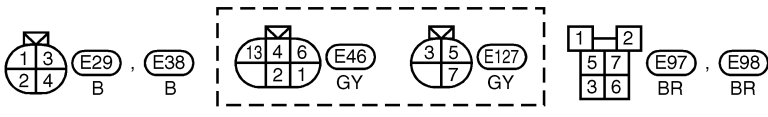

MEL863L

THEFT WARNING SYSTEM

Trouble Diagnoses

PRECAUTIONS FOR INFINITI COMMUNICATOR (IVCS)

NBEL0123

NBEL0123S12

The purpose of INFINITI Communicator is to increase security for the vehicle owner by providing a convenient way to contact the most appropriate emergency assistance provider during an emergency.

Improper operation of the system may result in a police response. The theft warning system also activates INFINITI Communicator. For details, refer to INFINITI Communicator (IVCS), EL-348.

PRELIMINARY CHECK

NBEL0123S01

The system operation is canceled by turning ignition switch to "ACC" at any step between START and ARMED in the following flow chart.

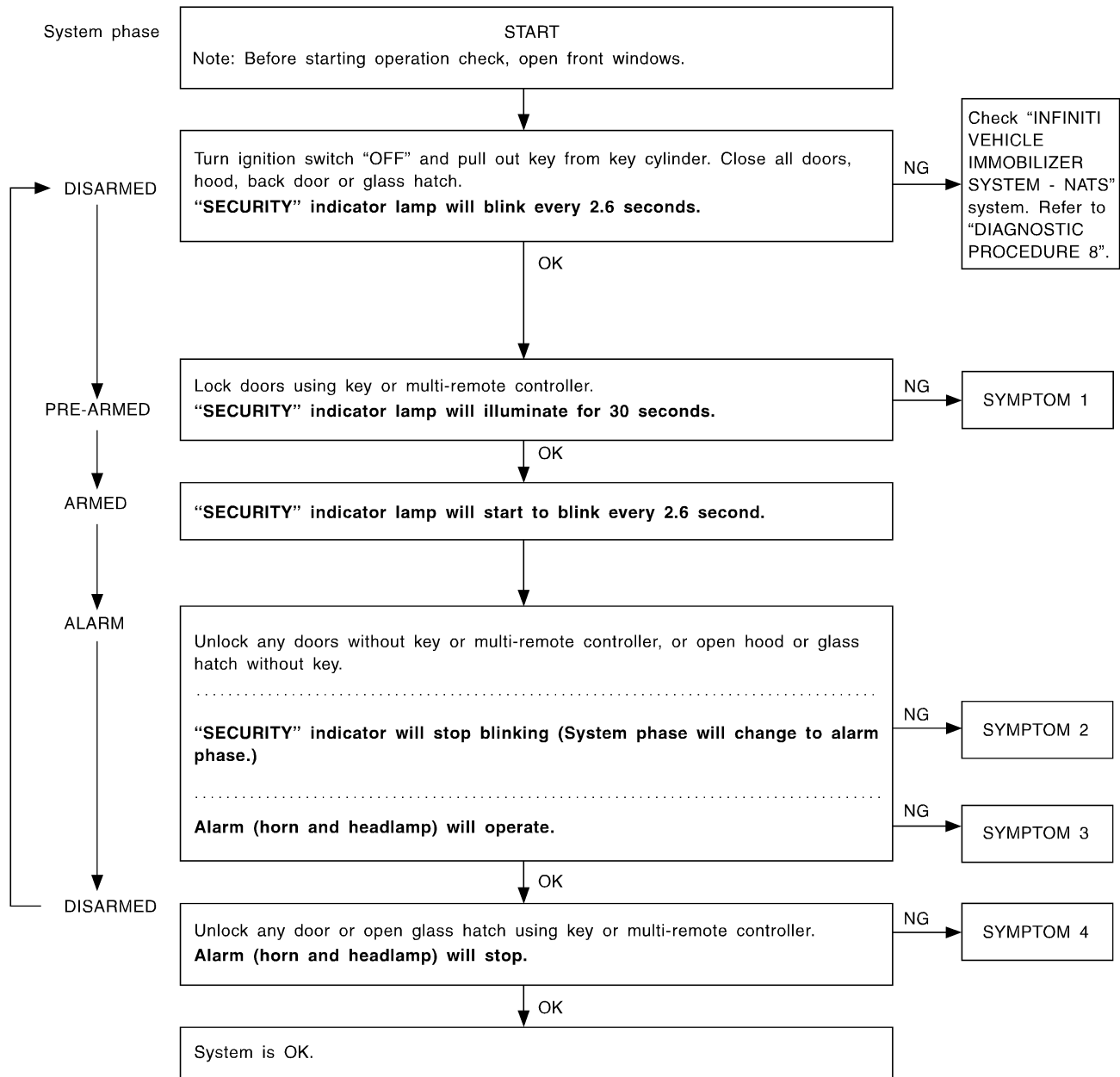

THEFT WARNING SYSTEM

Trouble Diagnoses (Cont'd)

After performing preliminary check, go to symptom chart below.

SYMPTOM CHART

NBEL0123S02

REFERENCE PAGE (EL-)	306	308	309	312	313	314	315	316	318	277	
SYMPTOM	PRELIMINARY CHECK	POWER SUPPLY AND GROUND CIRCUIT CHECK	DOOR, HOOD AND GLASS HATCH SWITCH CHECK	SECURITY INDICATOR LAMP CHECK	DOOR UNLOCK SENSOR CHECK	DOOR KEY CYLINDER SWITCH CHECK	BACK DOOR KEY CYLINDER SWITCH CHECK	HORN ALARM CHECK	THEFT WARNING HEADLAMP ALARM CHECK	Check "MULTI-REMOTE CONTROL" system.	
1	Theft warning indicator does not illuminate for 30 seconds.	X	X	X	X						
	Theft warning system cannot be set by ...	All items	X	X	X	X					
		Door outside key	X				X				
		Back door key	X					X			
	Multi-remote control	X								X	
2	*1 Theft warning system does not alarm when ...	Any door is opened.	X	X							
		Any door is unlocked without using key or multi-remote controller	X			X					
3	Theft warning alarm does not activate.	All function	X	X	X						
		Horn alarm	X					X			
		Headlamp alarm	X						X		
4	Theft warning system cannot be canceled by ...	Door outside key	X			X					
		Back door key	X				X				
		Multi-remote control	X								X

X : Applicable

*1: Make sure the system is in the armed phase.

Before starting trouble diagnoses above, perform preliminary check, EL-306.

Symptom numbers in the symptom chart correspond with those of preliminary check.

THEFT WARNING SYSTEM

Trouble Diagnoses (Cont'd)

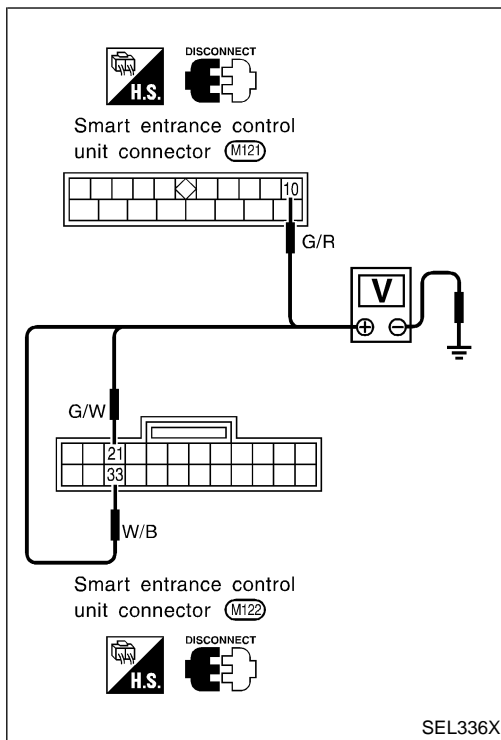

POWER SUPPLY AND GROUND CIRCUIT CHECK

NBEL0123S03

Power Supply Circuit Check

NBEL0123S0301

Terminals		Ignition switch position		
(+)	(-)	OFF	ACC	ON
10	Ground	Battery voltage	Battery voltage	Battery voltage
21	Ground	0V	Battery voltage	Battery voltage
33	Ground	0V	0V	Battery voltage

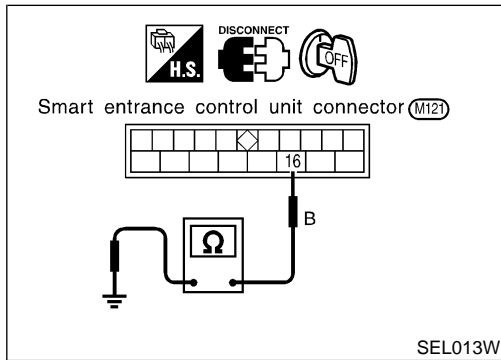

Ground Circuit Check

NBEL0123S0302

Terminals	Continuity
16 - Ground	Yes

THEFT WARNING SYSTEM

Trouble Diagnoses (Cont'd)

DOOR, HOOD AND GLASS HATCH SWITCH CHECK

=NBEL0123S04

Door Switch Check

NBEL0123S0401

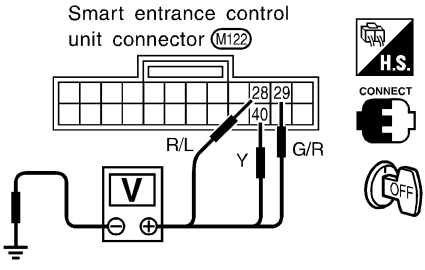
1	CHECK DOOR SWITCH INPUT SIGNAL																														
Check voltage between smart entrance control unit terminals 28, 29 or 40 and ground.																															
		<table border="1" style="width: 100%; border-collapse: collapse;"> <thead> <tr> <th rowspan="2"></th> <th colspan="2">Terminals</th> <th rowspan="2">Condition</th> <th rowspan="2">Voltage [V]</th> </tr> <tr> <th>(+)</th> <th>(-)</th> </tr> </thead> <tbody> <tr> <td rowspan="2">Front LH door switch</td> <td rowspan="2">29</td> <td rowspan="2">ground</td> <td>Open</td> <td>0</td> </tr> <tr> <td>Closed</td> <td>Approx. 5</td> </tr> <tr> <td rowspan="2">Front RH door switch</td> <td rowspan="2">40</td> <td rowspan="2">ground</td> <td>Open</td> <td>0</td> </tr> <tr> <td>Closed</td> <td>Approx. 5</td> </tr> <tr> <td rowspan="2">Rear and back door switches</td> <td rowspan="2">28</td> <td rowspan="2">ground</td> <td>Open</td> <td>0</td> </tr> <tr> <td>Closed</td> <td>Approx. 5</td> </tr> </tbody> </table>			Terminals		Condition	Voltage [V]	(+)	(-)	Front LH door switch	29	ground	Open	0	Closed	Approx. 5	Front RH door switch	40	ground	Open	0	Closed	Approx. 5	Rear and back door switches	28	ground	Open	0	Closed	Approx. 5
	Terminals		Condition		Voltage [V]																										
	(+)	(-)																													
Front LH door switch	29	ground	Open	0																											
			Closed	Approx. 5																											
Front RH door switch	40	ground	Open	0																											
			Closed	Approx. 5																											
Rear and back door switches	28	ground	Open	0																											
			Closed	Approx. 5																											
Refer to wiring diagram in EL-301.		SEL305X																													
OK or NG																															
OK	▶	Door switch is OK, and go to hood switch check.																													
NG	▶	GO TO 2.																													

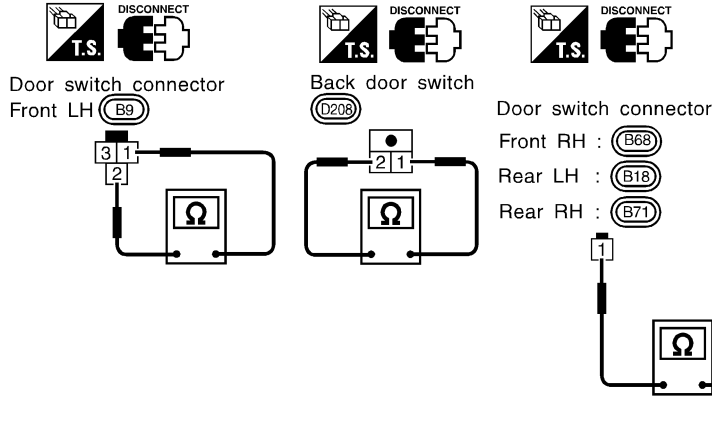
2	CHECK DOOR SWITCH																								
<ol style="list-style-type: none"> Disconnect door switch connector. Check continuity between door switch terminals. 																									
		<table border="1" style="width: 100%; border-collapse: collapse;"> <thead> <tr> <th></th> <th>Terminals</th> <th>Condition</th> <th>Continuity</th> </tr> </thead> <tbody> <tr> <td rowspan="2">Front LH door switch</td> <td rowspan="2">1 - 2</td> <td>Closed</td> <td>No</td> </tr> <tr> <td>Open</td> <td>Yes</td> </tr> <tr> <td rowspan="2">Back door switch</td> <td rowspan="2">1 - 2</td> <td>Closed</td> <td>No</td> </tr> <tr> <td>Open</td> <td>Yes</td> </tr> <tr> <td rowspan="2">Front RH and rear door switches</td> <td rowspan="2">1 - ground</td> <td>Closed</td> <td>No</td> </tr> <tr> <td>Open</td> <td>Yes</td> </tr> </tbody> </table>			Terminals	Condition	Continuity	Front LH door switch	1 - 2	Closed	No	Open	Yes	Back door switch	1 - 2	Closed	No	Open	Yes	Front RH and rear door switches	1 - ground	Closed	No	Open	Yes
	Terminals	Condition	Continuity																						
Front LH door switch	1 - 2	Closed	No																						
		Open	Yes																						
Back door switch	1 - 2	Closed	No																						
		Open	Yes																						
Front RH and rear door switches	1 - ground	Closed	No																						
		Open	Yes																						
		SEL306X																							
OK or NG																									
OK	▶	Check the following. <ul style="list-style-type: none"> Door switch ground circuit (Front LH, back door) or door switch ground condition Harness for open or short between smart entrance control unit and door switch 																							
NG	▶	Replace door switch.																							

GI
MA
EM
LC
EC
FE
AT
TF
PD
AX
SU
BR
ST
RS
BT
HA
SC
EL
IDX

THEFT WARNING SYSTEM

Trouble Diagnoses (Cont'd)

Hood Switch Check

=NBEL0123S0402

1	CHECK HOOD SWITCH FITTING CONDITION	
OK or NG		
OK	▶	GO TO 2.
NG	▶	Adjust installation of hood switch or hood.

2	CHECK HOOD SWITCH INPUT SIGNAL	
Check voltage between smart entrance control unit terminal 27 and ground.		
<div style="display: flex; align-items: center;"> <div style="flex: 1;"> </div> <div style="flex: 1; padding-left: 20px;"> <p>Voltage [V]: Hood is open. 0 Hood is closed. Approx. 5</p> </div> </div>		
SEL337X		
OK or NG		
OK	▶	Hood switch is OK, and go to glass hatch switch check.
NG	▶	GO TO 3.



3	CHECK HOOD SWITCH	
<p>1. Disconnect hood switch connector. 2. Check continuity between hood switch terminals 1 and 2.</p>		
<div style="display: flex; align-items: center;"> <div style="flex: 1;"> </div> <div style="flex: 1; padding-left: 20px;"> <p>Continuity: Condition: Pushed No Condition: Released Yes</p> </div> </div>		
SEL338X		
OK or NG		
OK	▶	<p>Check the following.</p> <ul style="list-style-type: none"> ● Hood switch ground circuit ● Harness for open or short between smart entrance control unit and hood switch
NG	▶	Replace hood switch.

THEFT WARNING SYSTEM

Trouble Diagnoses (Cont'd)

Glass Hatch Switch Check

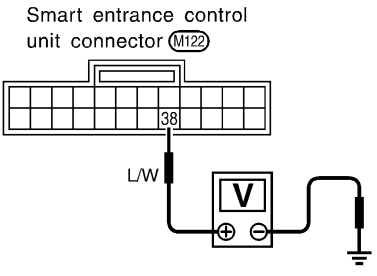
=NBEL0123S0403

1	CHECK GLASS HATCH SWITCH INPUT SIGNAL		GI MA EM LC EC FE AT
<p>Check voltage between smart entrance control unit terminal 38 and ground.</p> <div style="display: flex; justify-content: space-around; align-items: flex-start;"> <div style="text-align: center;"> <p>Smart entrance control unit connector (M122)</p>  <p>L/W</p> </div> <div style="text-align: center;">  </div> <div style="text-align: left;"> <p>Voltage [V]: Glass hatch is open. Approx. 0 Glass hatch is closed. Approx. 12</p> </div> </div> <p style="text-align: right;">SEL339X</p>			
Refer to wiring diagram in EL-300.			
OK or NG			
OK	▶	Glass hatch switch is OK.	
NG	▶	GO TO 2.	

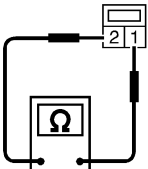
2	CHECK GLASS HATCH SWITCH		TF PD AX SU BR ST RS BT HA SC
<p>1. Disconnect glass hatch switch connector. 2. Check continuity between glass hatch switch terminals 1 and 2.</p> <div style="display: flex; justify-content: space-around; align-items: flex-start;"> <div style="text-align: center;">  <p>Glass hatch switch connector (D209)</p>  </div> <div style="text-align: left;"> <p>Continuity: Condition: Closed No Condition: Open Yes</p> </div> </div> <p style="text-align: right;">SEL340X</p>			
OK or NG			
OK	▶	<p>Check the following.</p> <ul style="list-style-type: none"> ● Glass hatch switch ground circuit ● Harness for open or short between smart entrance control unit and glass hatch switch 	
NG	▶	Replace glass hatch switch.	

EL

IDX

THEFT WARNING SYSTEM

Trouble Diagnoses (Cont'd)

SECURITY INDICATOR LAMP CHECK

=NBEL0123S05

1	CHECK INDICATOR LAMP OUTPUT SIGNAL		
<p>1. Disconnect smart entrance control unit connector. 2. Check voltage between control unit terminal 31 and ground.</p>			
Battery voltage should exist.			
SEL341X			
OK or NG			
OK	▶	Security indicator lamp is OK.	
NG	▶	GO TO 2.	

2	CHECK INDICATOR LAMP		
OK or NG			
OK	▶	GO TO 3.	
NG	▶	Replace indicator lamp.	



3	CHECK POWER SUPPLY CIRCUIT FOR INDICATOR LAMP		
<p>1. Disconnect security lamp connector. 2. Check voltage between indicator lamp terminal 1 and ground.</p>			
Battery voltage should exist.			
SEL342X			
OK or NG			
OK	▶	Check harness for open or short between security indicator lamp and control unit.	
NG	▶	<p>Check the following.</p> <ul style="list-style-type: none"> ● 7.5A fuse [No. 24, located in fuse block (J/B)] ● Harness for open or short between security indicator lamp and fuse 	

THEFT WARNING SYSTEM

Trouble Diagnoses (Cont'd)

DOOR UNLOCK SENSOR CHECK

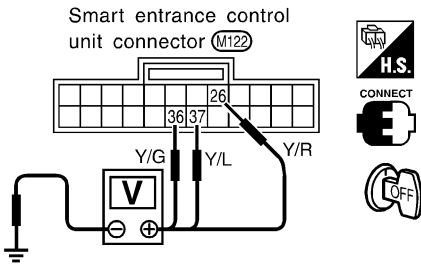
=NBEL0123S06

1	CHECK DOOR UNLOCK SENSOR INPUT SIGNAL																														
<p>Check voltage between smart entrance control unit terminals 26, 36 or 37 and ground.</p>																															
																															
		<table border="1" style="width: 100%; border-collapse: collapse;"> <thead> <tr> <th rowspan="2"></th> <th colspan="2">Terminals</th> <th rowspan="2">Condition</th> <th rowspan="2">Voltage [V]</th> </tr> <tr> <th>(+)</th> <th>(-)</th> </tr> </thead> <tbody> <tr> <td rowspan="2">Front LH door</td> <td rowspan="2">36</td> <td rowspan="2">Ground</td> <td>Locked</td> <td>Approx. 5</td> </tr> <tr> <td>Unlocked</td> <td>0</td> </tr> <tr> <td rowspan="2">Front RH door</td> <td rowspan="2">37</td> <td rowspan="2">Ground</td> <td>Locked</td> <td>Approx. 5</td> </tr> <tr> <td>Unlocked</td> <td>0</td> </tr> <tr> <td rowspan="2">Rear and back door</td> <td rowspan="2">26</td> <td rowspan="2">Ground</td> <td>Locked</td> <td>Approx. 5</td> </tr> <tr> <td>Unlocked</td> <td>0</td> </tr> </tbody> </table>			Terminals		Condition	Voltage [V]	(+)	(-)	Front LH door	36	Ground	Locked	Approx. 5	Unlocked	0	Front RH door	37	Ground	Locked	Approx. 5	Unlocked	0	Rear and back door	26	Ground	Locked	Approx. 5	Unlocked	0
	Terminals		Condition		Voltage [V]																										
	(+)	(-)																													
Front LH door	36	Ground	Locked	Approx. 5																											
			Unlocked	0																											
Front RH door	37	Ground	Locked	Approx. 5																											
			Unlocked	0																											
Rear and back door	26	Ground	Locked	Approx. 5																											
			Unlocked	0																											
Refer to wiring diagram in EL-304.		SEL343X																													
OK or NG																															
OK	▶	Door unlock sensor is OK.																													
NG	▶	GO TO 2.																													

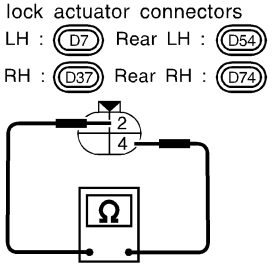
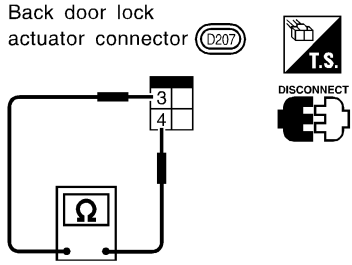
2	CHECK DOOR UNLOCK SENSOR		
<p>1. Disconnect door unlock sensor connector. 2. Check continuity between door unlock sensor terminals.</p>			
<p>Door lock actuator connectors</p> <p>Front LH : (D7) Rear LH : (D54)</p> <p>Front RH : (D37) Rear RH : (D74)</p> 		<p>Back door lock actuator connector (D207)</p> 	
		<p>Continuity:</p> <p>Condition: Locked No</p> <p>Condition: Unlocked Yes</p>	
		SEL344X	
OK or NG			
OK	▶	<p>Check the following.</p> <ul style="list-style-type: none"> ● Door unlock sensor ground circuit ● Harness for open or short between smart entrance control unit and door unlock sensor 	
NG	▶	Replace door unlock sensor.	

GI
MA
EM
LC
EC
FE
AT
TF
PD
AX
SU
BR
ST
RS
BT
HA
SC
EL
IDX

THEFT WARNING SYSTEM

Trouble Diagnoses (Cont'd)

FRONT DOOR KEY CYLINDER SWITCH CHECK

=NBEL0123S07

1 CHECK DOOR KEY CYLINDER SWITCH INPUT SIGNAL (LOCK/UNLOCK SIGNAL)

Check voltage between smart entrance control unit terminals 30 or 41 and ground.

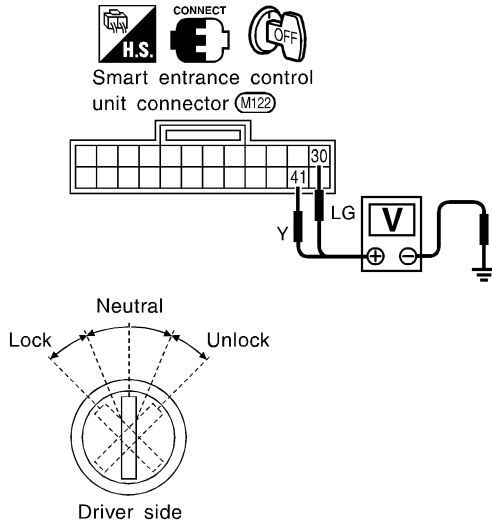

Terminals		Key position	Voltage [V]
(+)	(-)		
41	Ground	Neutral/Unlock	Approx. 5
		Lock	0
30	Ground	Neutral/Lock	Approx. 5
		Unlock	0

SEL312X

Refer to wiring diagram in EL-303.

OK or NG

OK ► Door key cylinder switch LH is OK.

NG ► GO TO 2.

2 CHECK DOOR KEY CYLINDER SWITCH

1. Disconnect door key cylinder switch LH connector.
2. Check continuity between door key cylinder switch LH terminals.

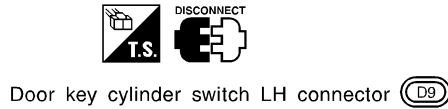

- ① : Door unlock switch terminal
- ② : Ground terminal
- ③ : Door lock switch terminal

Terminals	Key position	Continuity
LH: 3 - 2	Neutral/Unlock	No
	Lock	Yes
LH: 1 - 2	Neutral/Lock	No
	Unlock	Yes

SEL313X

OK or NG

OK ► **Check the following.**

- Door key cylinder switch LH ground circuit
- Harness for open or short between smart entrance control unit and door key cylinder switch LH

NG ► Replace door key cylinder switch LH.

THEFT WARNING SYSTEM

Trouble Diagnoses (Cont'd)

BACK DOOR KEY CYLINDER SWITCH CHECK

=NBEL0123S08

1 CHECK BACK DOOR KEY CYLINDER SWITCH INPUT SIGNAL (LOCK/UNLOCK SIGNAL)

Check voltage between smart entrance control unit terminals 30, 41 or 42 and ground.

	Terminals		Key position	Voltage [V]
	(+)	(-)		
Back door	41	Ground	Between neutral and lock	0
			Other positions	Approx. 5
	30	Ground	Between neutral and unlock	0
			Other positions	Approx. 5

Refer to wiring diagram in EL-304.

SEL314X

OK or NG

OK	▶	Back door key cylinder switch is OK.
NG	▶	GO TO 2.

2 CHECK BACK DOOR KEY CYLINDER SWITCH

- Disconnect back door key cylinder switch connector.
- Check continuity between back door key cylinder switch terminals.

Key position	Terminals			
	1	2	3	4
Between neutral and lock (Back door)	○			○
Between neutral and unlock (Back door)		○		○
Between lock (Back door) and unlock (glass hatch)			○	○

SEL345X

OK or NG

OK	▶	<p>Check the following.</p> <ul style="list-style-type: none"> Back door key cylinder switch ground circuit Harness for open or short between smart entrance control unit and back door key cylinder switch
NG	▶	Replace back door key cylinder switch.

GI
MA
EM
LC
EC
FE
AT
TF
PD
AX
SU
BR
ST
RS
BT
HA
SC
EL
IDX

THEFT WARNING SYSTEM

Trouble Diagnoses (Cont'd)

HORN ALARM CHECK

=NBEL0123S09

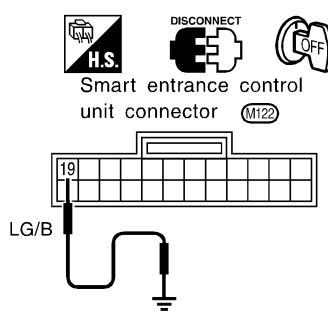
1	CHECK HORN ALARM OPERATION		
		<p>1. Disconnect smart entrance control unit connector.</p> <p>2. Apply ground to smart entrance control unit terminal 19.</p>	
			<p>Horn alarm should operate.</p>
		Refer to wiring diagram in EL-304.	SEL346X
		OK or NG	
OK	▶	Horn alarm is OK.	
NG	▶	GO TO 2.	

2	CHECK HORN RELAY		
		Check horn relay.	
		OK or NG	
OK	▶	GO TO 3.	
NG	▶	Replace horn relay.	

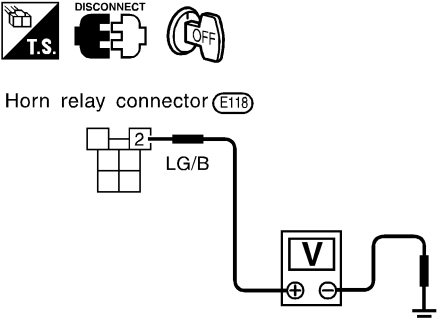
3	CHECK POWER SUPPLY FOR HORN RELAY		
		<p>1. Disconnect horn relay connector.</p> <p>2. Check voltage between terminal 2 and ground.</p>	
			<p>Battery voltage should exist.</p>
			SEL347X
		OK or NG	
OK	▶	GO TO 4.	
NG	▶	<p>Check the following.</p> <ul style="list-style-type: none"> ● 7.5A fuse (No. 52, located in the fuse and fusible link box) ● Harness for open or short between horn relay and fuse 	

THEFT WARNING SYSTEM

Trouble Diagnoses (Cont'd)

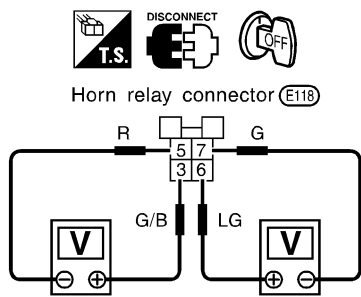
4	CHECK HORN RELAY CIRCUIT	
	<p>1. Disconnect horn relay connector.</p> <p>2. Check voltage between terminals 3 and 5.</p> <p>3. Check voltage between terminals 6 and 7.</p> <div style="text-align: center;">  <p>Horn relay connector (E118)</p> <p>Battery voltage should exist.</p> <p>SEL348X</p> <p>OK or NG</p> </div>	
OK	▶	Check harness for open or short between horn relay and smart entrance control unit.
NG	▶	Check harness for open or short.

GI

MA

EM

LC

EC

FE

AT

TF

PD

AX

SU

BR

ST

RS

BT

HA

SC

EL

IDX

THEFT WARNING SYSTEM

Trouble Diagnoses (Cont'd)

THEFT WARNING HEADLAMP ALARM CHECK

=NBEL0123S10

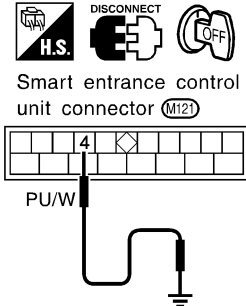
1	CHECK THEFT WARNING HEADLAMP ALARM OPERATION	
<p>1. Disconnect smart entrance control unit connector. 2. Apply ground to smart entrance control unit terminal 4.</p> <div style="display: flex; align-items: center; justify-content: center;">  <div style="margin-left: 20px;"> <p>Headlamp alarm should operate.</p> </div> </div> <p style="text-align: right;">SEL570X</p>		
Refer to wiring diagram in EL-304.		
OK or NG		
OK	▶	Headlamp alarm is OK.
NG	▶	GO TO 2.

2	CHECK HEADLAMP OPERATION	
Does headlamp come on when turning lighting switch "ON"?		
Yes	▶	Check harness for open or short between headlamp relay and smart entrance control unit.
No	▶	Check headlamp system. Refer to "HEADLAMP".

SMART ENTRANCE CONTROL UNIT

Description

Description

NBEL0124

The following systems are controlled by the smart entrance control unit.

- Warning chime
- Rear window defogger and door mirror defogger timer
- Power door lock
- Multi-remote control system
- Theft warning system
- Interior lamp timer
- Electric sunroof and power window timer
- Headlamp battery saver
- Battery saver

For detailed description and wiring diagrams, refer to the relevant pages for the each system.

The smart entrance control unit receives data from the switches and sensors to control their corresponding system relays and actuators.

INPUT/OUTPUT

NBEL0124S01

System	Input	Output
Power door lock	Door lock and unlock switch LH and RH Key switch (Insert) Door switches Door key cylinder switches	Door lock actuator
Multi-remote control	Key switch (Insert) Ignition switch (ACC) Door switches Front door unlock sensor LH Door lock and unlock switch LH Remote controller signal	Horn relay Headlamp relay (LH and RH) Interior lamp Multi-remote control relay Door lock actuator
Warning chime	Key switch (Insert) Ignition switch (ON) Lighting switch (1st) Seat belt switch Front door switch LH	Warning chime (located in smart entrance control unit)
Rear window defogger and door mirror defogger timer	Ignition switch (ON) Rear window defogger switch	Rear window defogger relay
Theft warning	Ignition switch (ACC, ON) Door switches Hood switch Glass hatch switch Door key cylinder switches (lock/unlock) Door unlock sensors	Horn relay Headlamp relay (LH and RH) Security indicator
Interior lamp timer	Door switches Front door unlock sensor LH Ignition switch (ON) Key switch (Insert)	Interior lamp
Electric sunroof and power window timer	Front door switches Ignition switch (ON)	Power window relay
Headlamp battery saver timer	Front door switches Ignition switch (ON)	Headlamp battery saver control unit
Battery saver	Ignition switch (ON) Door switches Driver's door unlock sensor Key switch (Insert)	Interior lamp Luggage room lamp Spot lamp Vanity mirror illumination lamp

SMART ENTRANCE CONTROL UNIT

Description (Cont'd)

BATTERY SAVER

NBEL0124S02

The lamp turns off automatically when the interior lamp, luggage room lamp, spot lamp or/and vanity mirror illumination is illuminated with the ignition key in the OFF position, if the lamp remains lit by the door switch open signal or if the lamp switch is in the ON position for more than 10 minutes.

After lamps turn off by the battery saver system, the lamps illuminate again when:

- driver's door is locked or unlocked,
- door is opened or closed,
- key is inserted in ignition key cylinder.

SMART ENTRANCE CONTROL UNIT

Description (Cont'd)

NOTE:

GI

MA

EM

LC

EC

FE

AT

TF

PD

AX

SU

BR

ST

RS

BT

HA

SC

EL

IDX

SMART ENTRANCE CONTROL UNIT

Schematic

Schematic

NBEL0125

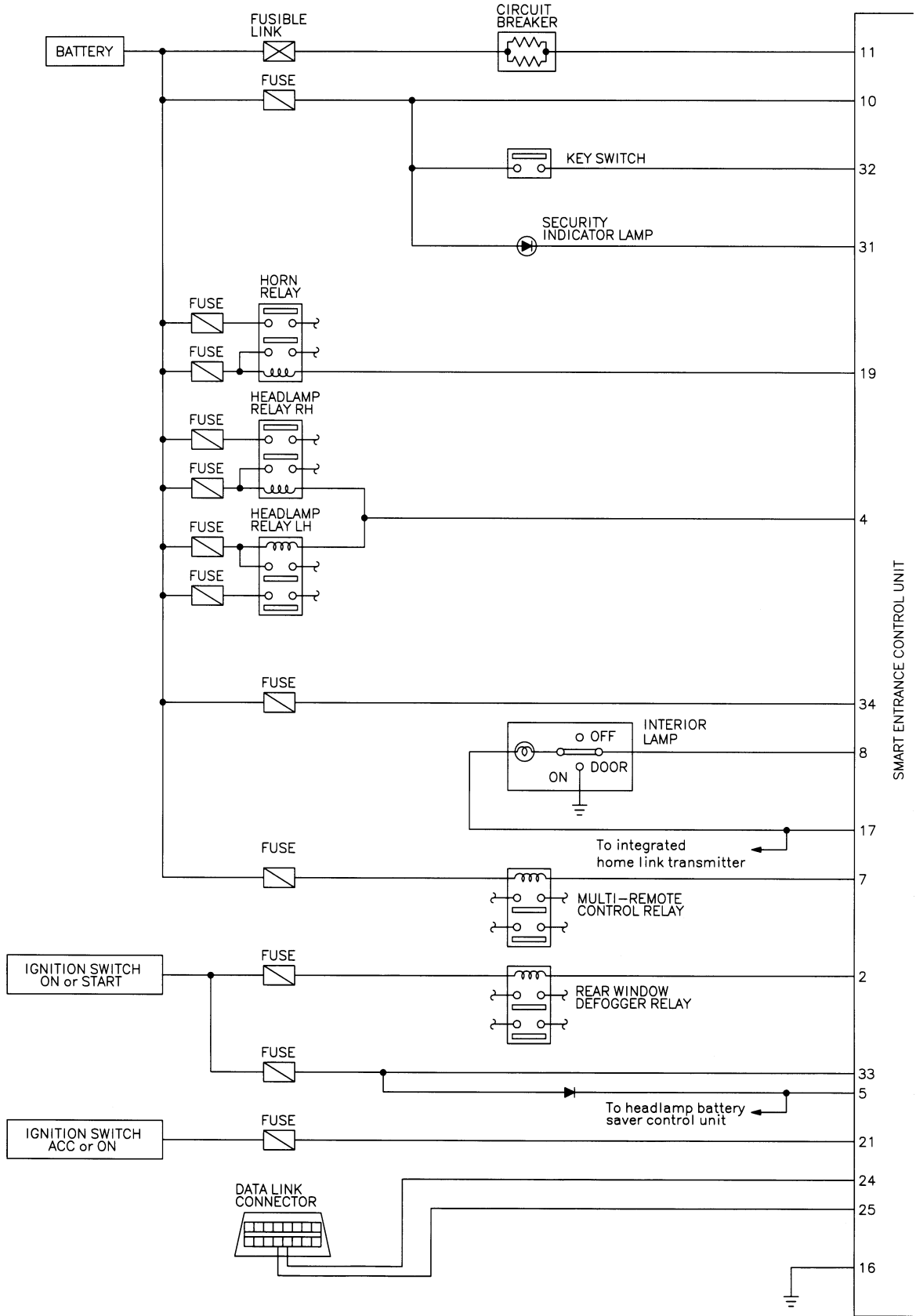

MEL864L

SMART ENTRANCE CONTROL UNIT

Schematic (Cont'd)

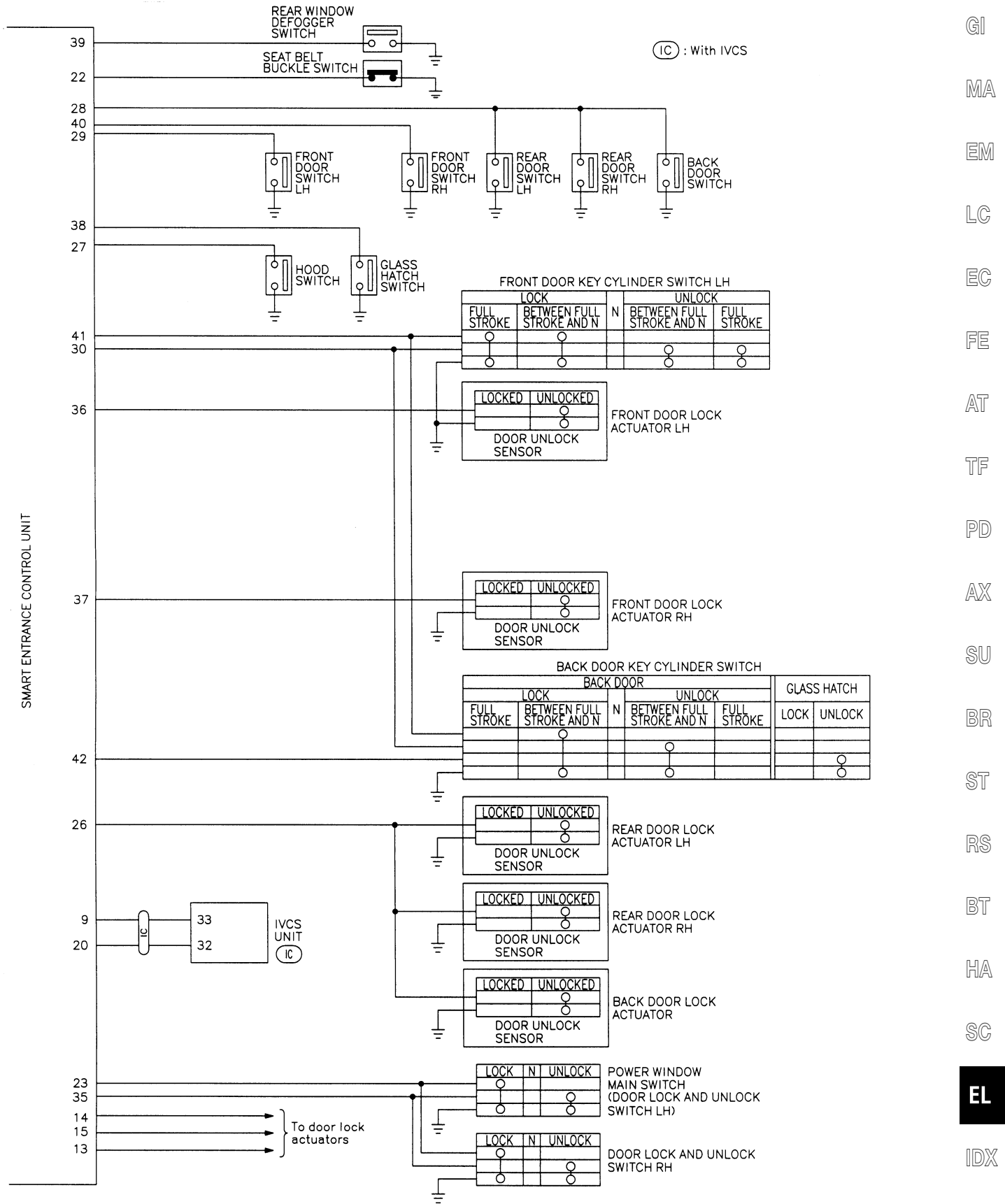

SMART ENTRANCE CONTROL UNIT

Smart Entrance Control Unit Inspection Table

Smart Entrance Control Unit Inspection Table

NBEL0126

Terminal No.	Wire color	Connections	Operated condition	Voltage (Approximate values)	
2	G/B	Rear window defogger relay	OFF → ON (Ignition key is in "ON" position)	0V → 12V	
4	PU/W	Theft warning horn/lamp relay	When panic alarm is operated using remote controller	12V → 0V	
5	R/Y	Headlamp battery saver control unit	When headlamp battery saver timer is operated	12V	
7	P	Multi-remote control relay	When doors are locked using remote controller	12V → 0V	
8	R/B	Interior lamp	When interior lamp is operated using remote controller. (Lamp switch in "DOOR" position)	0V → 12V	
10	G/R	Power source (Fuse)	—	12V	
11	W/R	Power source (C/B)	—	12V	
13	W/PU	Driver door lock actuator	Door lock & unlock switch	Free	0V
14	Y/B	Passenger door lock actuator		Unlocked	12V
15	L	Door lock actuators	Door lock & unlock switch	Free	0V
				Locked	12V
16	B	Ground	—	—	
17	R/W	Battery saver (Interior lamp)	Battery saver is not operate → Operate	12V → 0V	
19	LG/B	Horn relay	When doors are locked using remote controller with horn chirp mode.	12V → 0V	
21	G/W	Ignition switch (ACC)	"ACC" position	12V	
22	B/P	Seat belt buckle switch	Unfasten → Fasten (Ignition key is in "ON" position)	0V → 12V	
23	BR	Door lock & unlock switches	Neutral → Locks	5V → 0V	
26	Y/R	Rear door unlock sensors	All doors are locked → One or more doors are unlocked	5V → 0V	
27	Y/B	Hood open signal	ON (Open) → OFF (Closed)	0V → 5V	
28	R/L	Rear and back door switches	OFF (Closed) → ON (Open)	5V → 0V	
29	G/R	Driver door switch	OFF (Closed) → ON (Open)	5V → 0V	
30	LG	Door key cylinder unlock switch	OFF (Neutral) → ON (Unlocked)	12V → 0V	
31	BR/Y	Theft warning indicator	Goes off → Illuminates	12V → 0V	
32	W/R	Ignition key switch (Insert)	key inserted → key removed from IGN key cylinder	12V → 0V	
33	W/B	Ignition switch (ON)	Ignition key is in "ON" position	12V	
35	LG/R	Door lock & unlock switches	Neutral → Unlocks	5V → 0V	
36	Y/G	Driver door unlock sensor	Driver door: Locked → Unlocked	5V → 0V	
37	Y/L	Passenger door unlock sensor	Passenger door: Locked → Unlocked	5V → 0V	
38	L/W	Glass hatch switch	ON (Open) → OFF (Closed)	0V → 12V	
39	OR	Rear window defogger switch	OFF → ON	5V → 0V	
40	Y	Passenger door switch	OFF (Closed) → ON (Open)	5V → 0V	
41	Y	Door key cylinder lock switch	OFF (Neutral) → ON (Locked)	5V → 0V	
42	G/B	Back door key unlock switch	OFF (Neutral) → ON (Unlock)	5V → 0V	

INTEGRATED HOMELINK TRANSMITTER

Wiring Diagram — TRNSMT —

Wiring Diagram — TRNSMT —

NBEL0127

EL-TRNSMT-01

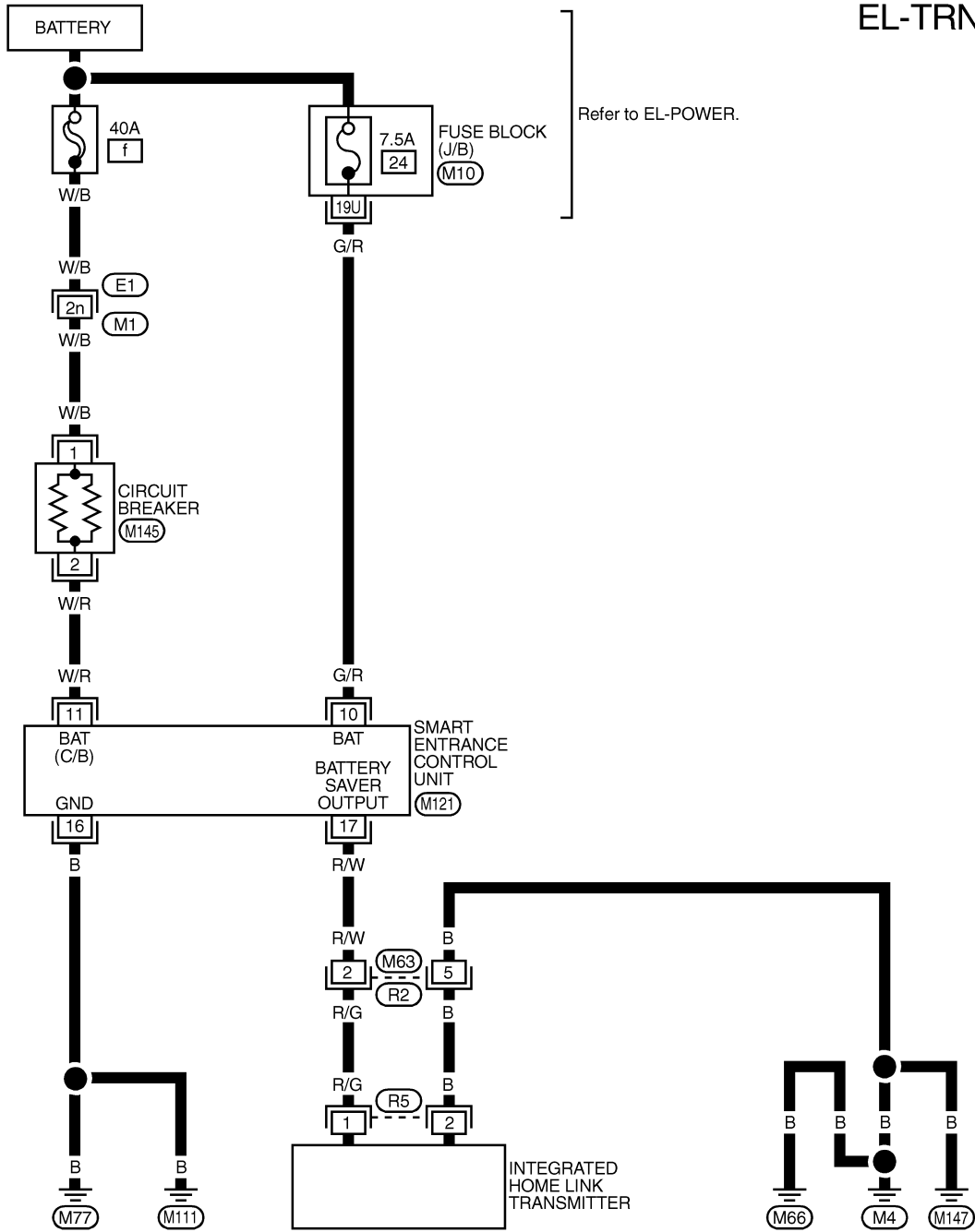

Refer to EL-POWER.

GI
MA
EM
LC
EC
FE
AT
TF
PD
AX
SU
BR
ST
RS
BT
HA
SC
EL
IDX

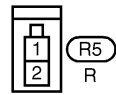
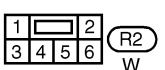
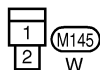
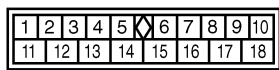

REFER TO THE FOLLOWING.
 (E1) -SUPER
 MULTIPLE JUNCTION (SMJ)
 (M10) -FUSE BLOCK-
 JUNCTION BOX (J/B)

MEL866L

INTEGRATED HOMELINK TRANSMITTER

Trouble Diagnoses

Trouble Diagnoses

DIAGNOSTIC PROCEDURE

NBEL0128

NBEL0128S01

SYMPTOM: Transmitter does not activate receiver.

Before conducting the procedure given below, make sure that system receiver (garage door opener, etc.) operates with original, hand-held transmitter. If NG, receiver or hand-held transmitter is at fault, not vehicle related.

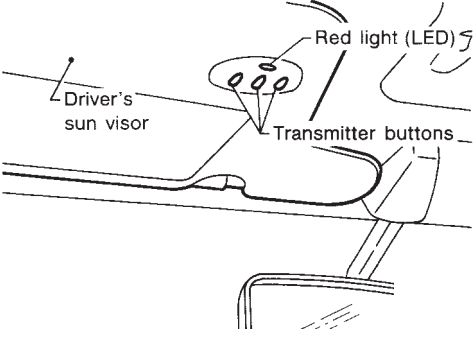
1	PRELIMINARY CHECK
<p>1. Turn ignition switch "OFF". 2. Does red light (LED) of transmitter illuminate when any button is pressed?</p>	
	
Yes or No	
Yes	▶ GO TO 2.
No	▶ GO TO 3.

SEL442U

2	CHECK TRANSMITTER FUNCTION
<p>Check transmitter with Tool. For details, refer to Technical Service Bulletin.</p>	
OK or NG	
OK	▶ Receiver or handheld transmitter fault, not vehicle related.
NG	▶ Replace transmitter with sun visor assembly.

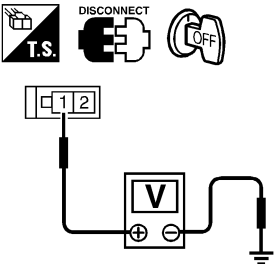
3	CHECK POWER SUPPLY
<p>1. Disconnect transmitter connector. 2. Turn ignition switch "OFF". 3. Check voltage between terminal 1 and body ground.</p>	
	
Battery voltage should exist.	
OK or NG	
OK	▶ GO TO 4.
NG	▶ GO TO 5.

SEL358X

INTEGRATED HOMELINK TRANSMITTER

Trouble Diagnoses (Cont'd)

4	CHECK GROUND CIRCUIT		
Check continuity between terminal 2 and ground.			
Continuity should exist.			
SEL359X			
OK or NG			
OK	▶	Replace transmitter with sun visor assembly.	
NG	▶	Repair harness.	

GI
MA
EM
LC
EC
FE

5	CHECK MAIN POWER SUPPLY FOR SMART ENTRANCE CONTROL UNIT		
1. Disconnect smart entrance control unit. 2. Check voltage between smart entrance control unit terminal 10 and ground.			
Battery voltage should exist.			
SEL360X			
OK or NG			
OK	▶	GO TO 6.	
NG	▶	Check the following. <ul style="list-style-type: none"> ● 7.5A fuse No. 24, located in fuse block (J/B) 	

AT
TF
PD
AX
SU
BR
ST
RS

6	CHECK GROUND CIRCUIT FOR SMART ENTRANCE CONTROL UNIT		
Check continuity between terminal 16 and ground.			
Continuity should exist.			
SEL361X			
OK or NG			
OK	▶	Power supply and ground circuits are OK.	
NG	▶	Check ground harness.	

BT
HA
SC
EL
IDX

IVIS (INFINITI VEHICLE IMMOBILIZER SYSTEM — NATS)

Component Parts and Harness Connector Location

Component Parts and Harness Connector Location

NBEL0170

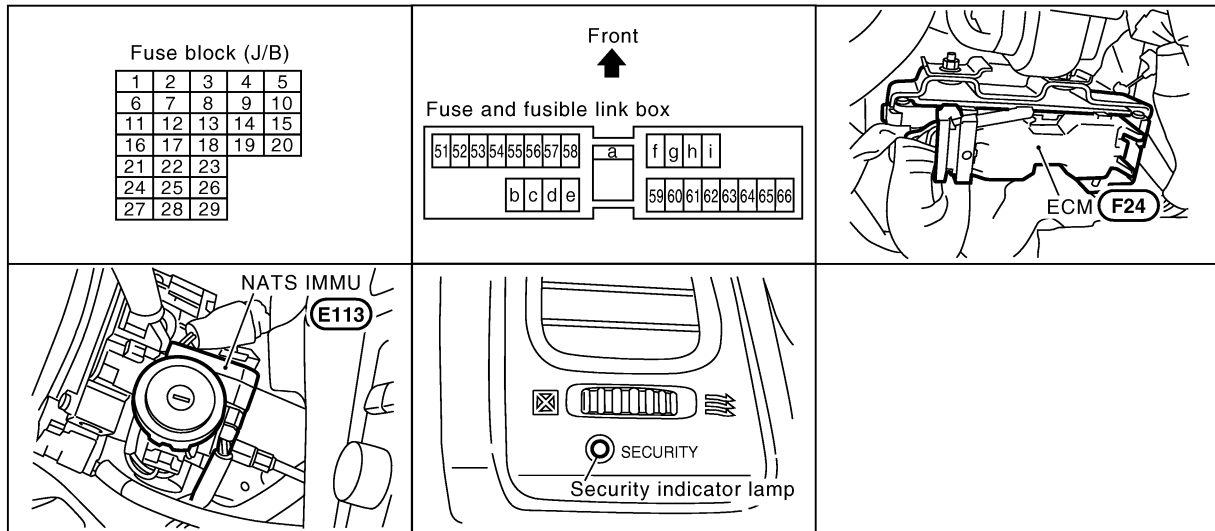

SEL357X

NOTE:

If customer reports a “No Start” condition, request ALL KEYS to be brought to an INFINITI dealer in case of an IVIS (NATS) malfunction.

System Description

=NBEL0171

NATS (Nissan Anti-Theft System) has the following immobilizer functions:

- Since only IVIS (NATS) ignition keys, whose ID nos. have been registered into the ECM and IMMU of IVIS (NATS), allow the engine to run, operation of a stolen vehicle without an IVIS (NATS) registered key is prevented by IVIS (NATS).
That is to say, IVIS (NATS) will immobilise the engine if someone tries to start it without the registered key of IVIS (NATS).
- All of the originally supplied ignition key IDs (except for card plate key) have been IVIS (NATS) registered. If requested by the vehicle owner, a maximum of five key IDs can be registered into the IVIS (NATS) components.
- The security indicator blinks when the ignition switch is in “OFF” or “ACC” position. Therefore, IVIS (NATS) warns outsiders that the vehicle is equipped with the anti-theft system.
- When IVIS (NATS) detects trouble, the security indicator lamp lights up while ignition key is in the “ON” position.
- IVIS (NATS) trouble diagnoses, system initialization and additional registration of other IVIS (NATS) ignition key IDs must be carried out using CONSULT-II hardware and CONSULT-II IVIS (NATS) software. When IVIS (NATS) initialization has been completed, the ID of the inserted ignition key is automatically IVIS (NATS) registered. Then, if necessary, additional registration of other IVIS (NATS) ignition key IDs can be carried out.
Regarding the procedures of IVIS (NATS) initialization and IVIS (NATS) ignition key ID registration, refer to CONSULT-II operation manual, IVIS/NVIS.
- **When servicing a malfunction of the IVIS (NATS) (indicated by lighting up of Security Indicator Lamp) or registering another IVIS (NATS) ignition key ID no., it is necessary to re-register original key identification. Therefore, be sure to receive ALL KEYS from vehicle owner.**

System Composition

NBEL0172

The immobiliser function of the IVIS (NATS) consists of the following:

- IVIS (NATS) ignition key
- IVIS (NATS) immobilizer control unit (IMMU) located in the ignition key cylinder
- Engine control module (ECM)
- Security indicator

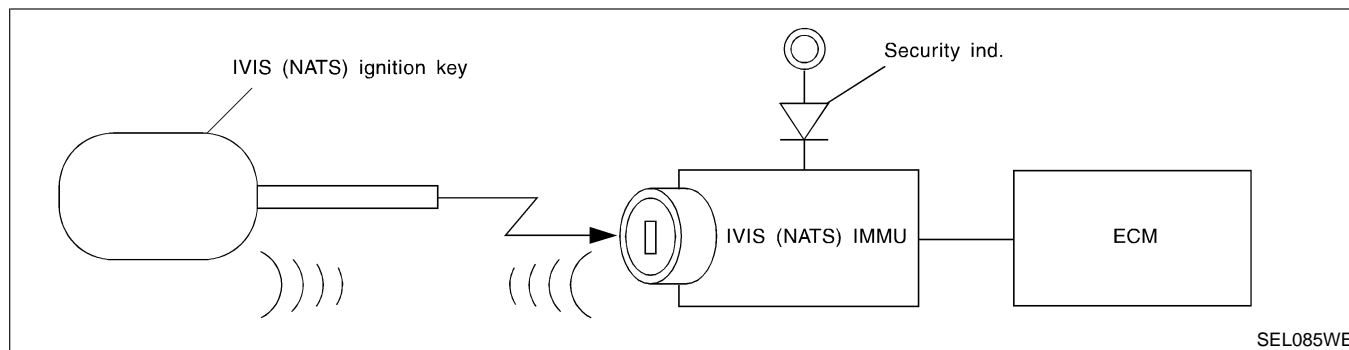

GI

MA

EM

LC

EC

FE

AT

TF

PD

AX

SU

BR

ST

RS

BT

HA

SC

EL

IDX

IVIS (INFINITI VEHICLE IMMOBILIZER SYSTEM — NATS)

Wiring Diagram — NATS —

Wiring Diagram — NATS —

NBEL0173

EL-NATS-01

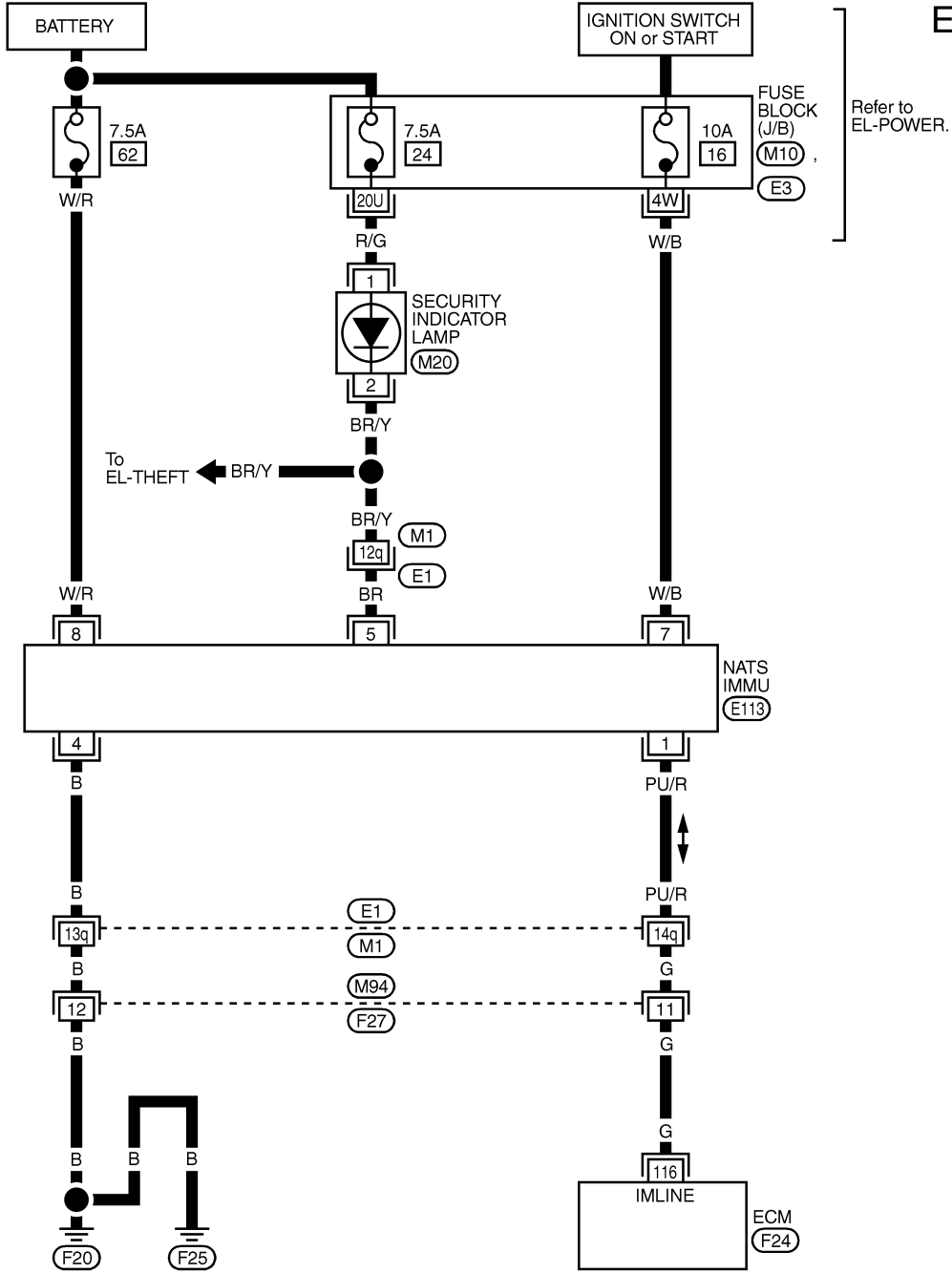

Refer to EL-POWER.

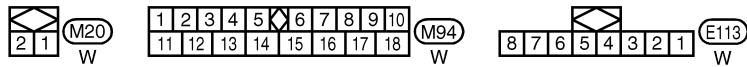

REFER TO THE FOLLOWING.

- (E1) -SUPER MULTIPLE JUNCTION (SMJ)
- (M10), (E3) -FUSE BLOCK-JUNCTION BOX (J/B)

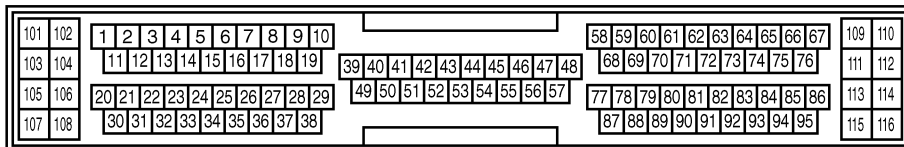

MEL865L

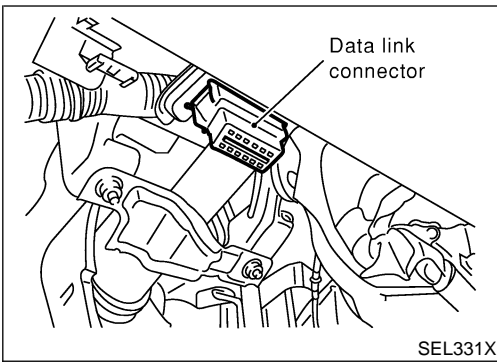

CONSULT-II

CONSULT-II INSPECTION PROCEDURE

NBEL0223

NBEL0223S01

1. Turn ignition switch OFF.
2. Insert IVIS (NATS) program card into CONSULT-II.

← : Program card
NATS (UEN99A)

3. Connect CONSULT-II to data link connector.

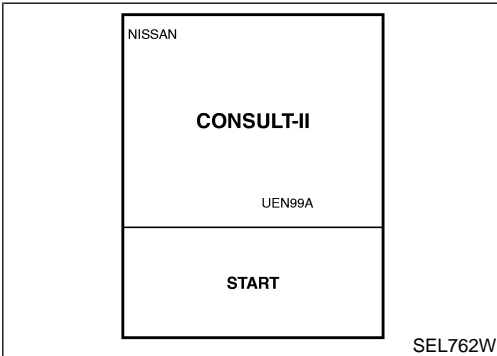

4. Turn ignition switch ON.
5. Touch "START".

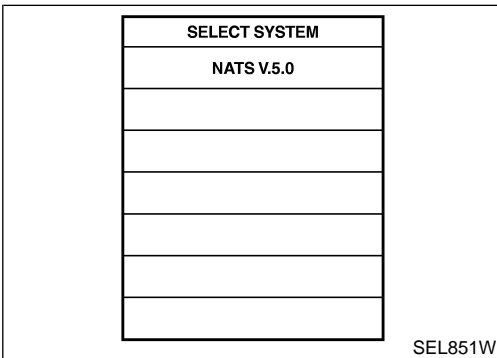

6. Select "NATS V.5.0".

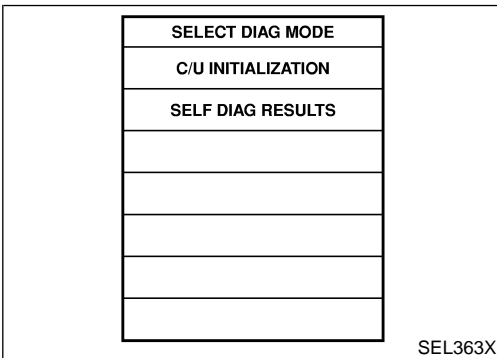

7. Perform each diagnostic test mode according to each service procedure.

For further information, see the CONSULT-II Operation Manual, IVIS/NVIS.

CONSULT-II DIAGNOSTIC TEST MODE FUNCTION

NBEL0223S02

CONSULT-II DIAGNOSTIC TEST MODE	Description
C/U INITIALIZATION	When replacing any of the following three components, C/U initialization and re-registration of all IVIS (NATS) ignition keys are necessary. [IVIS (NATS) ignition key/IMMU/ECM]
SELF-DIAG RESULTS	Detected items (screen terms) are as shown in the chart EL-332.

GI
MA
EM
LC
EC
FE
AT
TF
PD
AX
SU
BR
ST
RS
BT
HA
SC

EL

IDX

IVIS (INFINITI VEHICLE IMMOBILIZER SYSTEM — NATS)

CONSULT-II (Cont'd)

NOTE:

- When any initialization is performed, all ID previously registered will be erased and all IVIS (NATS) ignition keys must be registered again.
- The engine cannot be started with an unregistered key. In this case, the system will show “DIFFERENCE OF KEY” or “LOCK MODE” as a self-diagnostic result on the CONSULT-II screen.
- In rare case, “CHAIN OF ECM-IMMU” might be stored as a self-diagnostic result during key registration procedure, even if the system is not malfunctioning.

HOW TO READ SELF-DIAGNOSTIC RESULTS

NBEL0223S03

Result display screen (When no malfunction is detected)

SELF DIAG RESULTS	
DTC RESULTS	TIME
NO DTC IS DETECTED. FURTHER TESTING MAY BE REQUIRED.	
PRINT	

Result display screen (When malfunction is detected)

SELF DIAG RESULTS	
DTC RESULTS	TIME
CHAIN OF ECM-IMMU	0
DIFFERENCE OF KEY	1
Scroll down	
ERASE	PRINT

Detected items → CHAIN OF ECM-IMMU ← Time data
 This indicates how many times the vehicle was driven after the last detection of a malfunction. If the malfunction is detected currently, the time data will be “0”.

If “Scroll Down” is indicated, there are four or more malfunctions.

When touched, the results stored in the engine control module (ECM) are erased. ← When touched, the results are printed out.

SEL364X

IVIS (NATS) SELF-DIAGNOSTIC RESULTS ITEM CHART

NBEL0223S04

Detected items (NATS program card screen terms)	P No. Code (Self-diagnostic result of “ENGINE”)	Malfunction is detected when	Reference page
ECM INT CIRC-IMMU	NATS MAL-FUNCTION P1613	The malfunction of ECM internal circuit of IMMU communication line is detected.	EL-336
CHAIN OF ECM-IMMU	NATS MAL-FUNCTION P1612	Communication impossible between ECM and IMMU (In rare case, “CHAIN OF ECM-IMMU” might be stored during key registration procedure, even if the system is not malfunctioning.)	EL-337
DIFFERENCE OF KEY	NATS MAL-FUNCTION P1615	IMMU can receive the key ID signal but the result of ID verification between key ID and IMMU is NG.	EL-341
CHAIN OF IMMU-KEY	NATS MAL-FUNCTION P1614	IMMU cannot receive the key ID signal.	EL-342
ID DISCORD, IMM-ECM	NATS MAL-FUNCTION P1611	The result of ID verification between IMMU and ECM is NG. System initialization is required.	EL-343

IVIS (INFINITI VEHICLE IMMOBILIZER SYSTEM — NATS)

CONSULT-II (Cont'd)

Detected items (NATS program card screen terms)	P No. Code (Self-diagnostic result of "ENGINE")	Malfunction is detected when	Reference page
LOCK MODE	NATS MAL-FUNCTION P1610	When the starting operation is carried out five or more times consecutively under the following conditions, IVIS (NATS) will shift the mode to one which prevents the engine from being started. <ul style="list-style-type: none"> ● Unregistered ignition key is used. ● IMMU or ECM's malfunctioning. 	EL-346
DON'T ERASE BEFORE CHECKING ENG DIAG	—	All engine trouble codes except IVIS (NATS) trouble code has been detected in ECM.	EL-334

GI
MA
EM
LC
EC
FE
AT
TF
PD
AX
SU
BR
ST
RS
BT
HA
SC
EL
IDX

IVIS (INFINITI VEHICLE IMMOBILIZER SYSTEM — NATS)

Trouble Diagnoses

Trouble Diagnoses WORK FLOW

NBEL0224

NBEL0224S01

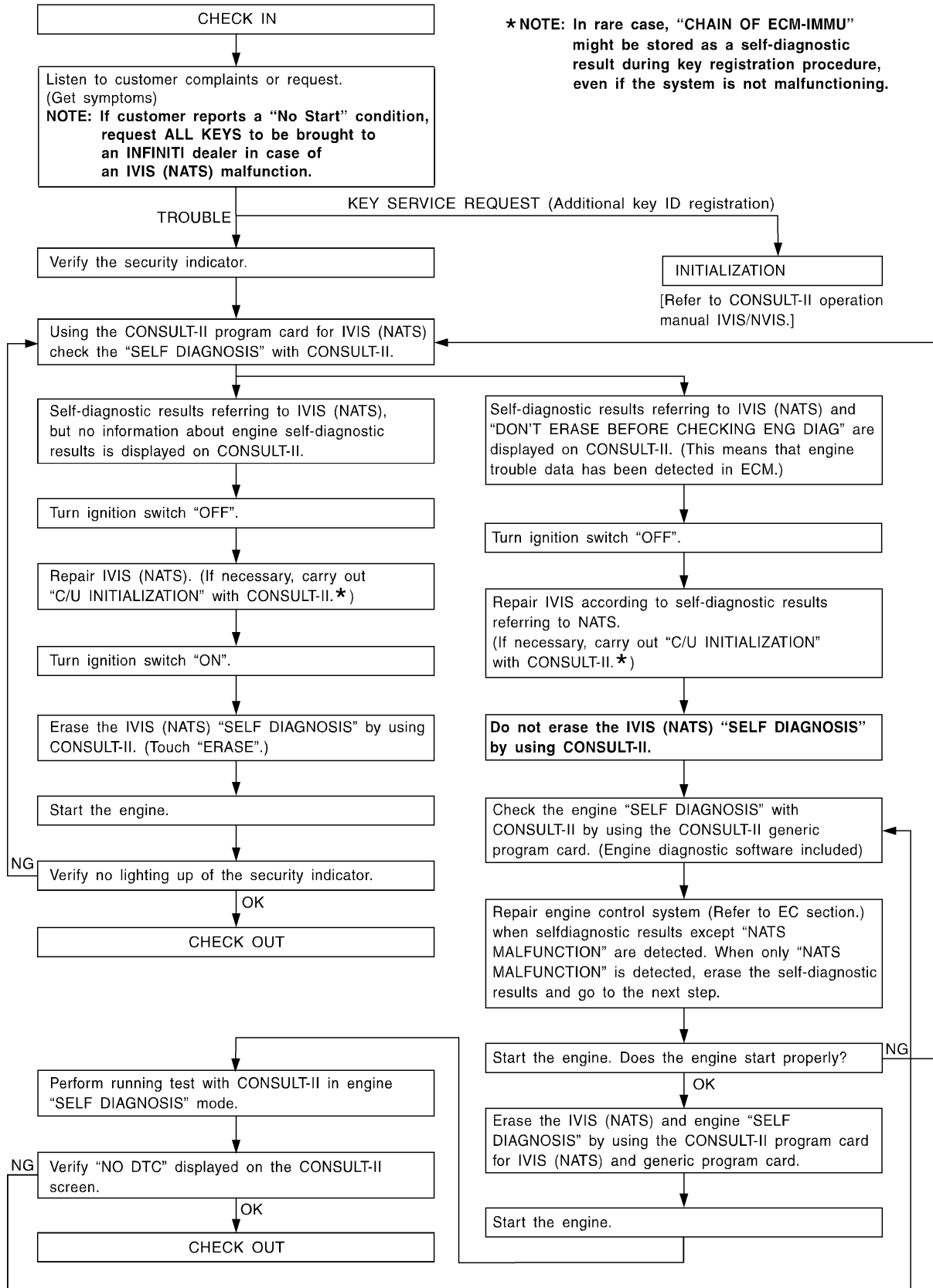

SEL024X

IVIS (INFINITI VEHICLE IMMOBILIZER SYSTEM — NATS)

Trouble Diagnoses (Cont'd)

SYMPTOM MATRIX CHART 1 (Self-diagnosis related item)

NBEL0224S02

SYMPTOM	Displayed "SELF-DIAG RESULTS" on CONSULT-II screen.	DIAGNOSTIC PROCEDURE (Reference page)	SYSTEM (Malfunctioning part or mode)	REFERENCE PART NO. OF ILLUSTRATION ON NEXT PAGE	
<ul style="list-style-type: none"> Security indicator lighting up* Engine cannot be started. 	ECM INT CIRC-IMMU	PROCEDURE 1 (EL-336)	ECM	B	GI
	CHAIN OF ECM-IMMU	PROCEDURE 2 (EL-337)	In rare case, "CHAIN OF ECM-IMMU" might be stored during key registration procedure, even if the system is not malfunctioning.	—	EM
			Open circuit in battery voltage line of IMMU circuit	C1	LC
			Open circuit in ignition line of IMMU circuit	C2	EC
			Open circuit in ground line of IMMU circuit	C3	FE
			Open circuit in communication line between IMMU and ECM	C4	AT
			Short circuit between IMMU and ECM communication line and battery voltage line	C4	TF
			Short circuit between IMMU and ECM communication line and ground line	C4	PD
			ECM	B	AX
			IMMU	A	SU
			DIFFERENCE OF KEY	PROCEDURE 3 (EL-341)	Unregistered key
	CHAIN OF IMMU-KEY	PROCEDURE 4 (EL-342)	Malfunction of key ID chip	E	ST
			IMMU	A	RS
	ID DISCORD, IMM-ECM	PROCEDURE 5 (EL-343)	System initialization has not yet been completed.	F	BT
			ECM	F	HA
LOCK MODE	PROCEDURE 7 (EL-346)	LOCK MODE	D	SC	
<ul style="list-style-type: none"> MIL staying ON Security indicator lighting up* 	DON'T ERASE BEFORE CHECKING ENG DIAG	WORK FLOW (EL-334)	Engine trouble data and IVIS (NATS) trouble data have been detected in ECM	—	EL

*: When IVIS (NATS) detects trouble, the security indicator lights up while ignition key is in the "ON" position.

IVIS (INFINITI VEHICLE IMMOBILIZER SYSTEM — NATS)

Trouble Diagnoses (Cont'd)

SYMPTOM MATRIX CHART 2 (Non self-diagnosis related item)

NBEL0224S03

SYMPTOM	DIAGNOSTIC PROCEDURE (Reference page)	SYSTEM (Malfunctioning part or mode)
Security ind. does not light up.	PROCEDURE 6 (EL-344)	Security ind.
		Open circuit between Fuse and IMMU
		Continuation of initialization mode
		IMMU

DIAGNOSTIC SYSTEM DIAGRAM

NBEL0224S04

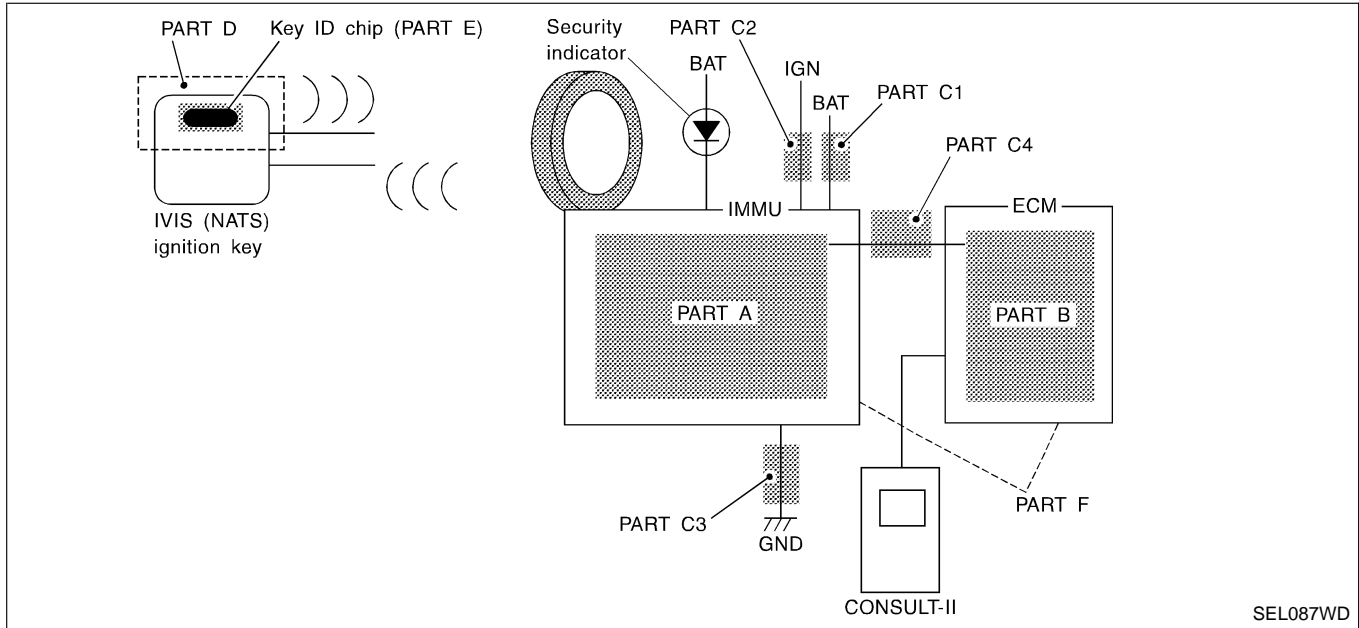

SEL087WD

SELF DIAG RESULTS	
DTC RESULTS	TIME
ECM INT CIRC-IMMU	0

SEL365X

DIAGNOSTIC PROCEDURE 1

NBEL0224S05

Self-diagnostic results:
“ECM INT CIRC-IMMU” displayed on CONSULT-II screen

1. Confirm SELF-DIAGNOSTIC RESULTS “ECM INT CIRC-IMMU” displayed on CONSULT-II screen. Ref. part No. B.
2. Replace ECM.
3. Perform initialization with CONSULT-II.
 For initialization, refer to “CONSULT-II operation manual IVIS/NVIS”.

IVIS (INFINITI VEHICLE IMMOBILIZER SYSTEM — NATS)

Trouble Diagnoses (Cont'd)

DIAGNOSTIC PROCEDURE 2

=NBEL0224S06

Self-diagnostic results:
"CHAIN OF ECM-IMMU" displayed on CONSULT-II screen

1	CONFIRM SELF-DIAGNOSTIC RESULTS											
<p>Confirm SELF-DIAGNOSTIC RESULTS "CHAIN OF ECM-IMMU" displayed on CONSULT-II screen.</p> <p>NOTE: In rare case, "CHAIN OF ECM-IMMU" might be stored during key registration procedure, even if the system is not malfunctioning.</p>												
<table border="1" style="margin: auto;"> <thead> <tr> <th colspan="2">SELF DIAG RESULTS</th> </tr> <tr> <th>DTC RESULTS</th> <th>TIME</th> </tr> </thead> <tbody> <tr> <td>CHAIN OF ECM-IMMU</td> <td style="text-align: center;">0</td> </tr> <tr> <td> </td> <td> </td> </tr> <tr> <td> </td> <td> </td> </tr> </tbody> </table>			SELF DIAG RESULTS		DTC RESULTS	TIME	CHAIN OF ECM-IMMU	0				
SELF DIAG RESULTS												
DTC RESULTS	TIME											
CHAIN OF ECM-IMMU	0											
SEL366X												
Is CONSULT-II screen displayed as above?												
Yes	▶	GO TO 2.										
No	▶	GO TO SYMPTOM MATRIX CHART 1.										

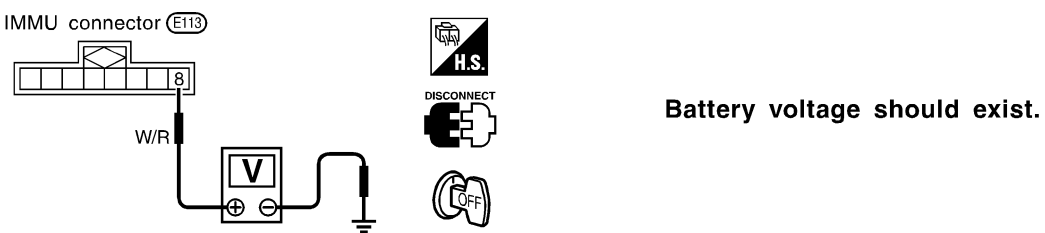
2	CHECK POWER SUPPLY CIRCUIT FOR IMMU	
<p>1. Disconnect IMMU connector.</p> <p>2. Check voltage between terminal 8 of IMMU and ground with CONSULT-II or tester.</p>		
		
SEL302WD		
OK or NG		
OK	▶	GO TO 3.
NG	▶	<p>Check the following</p> <ul style="list-style-type: none"> ● 7.5A fuse (No. 62, located in the fuse and fusible link box) ● Harness for open or short between fuse and IMMU connector <p>Ref. Part No. C1</p>

GI
MA
EM
LC
EC
FE
AT
TF
PD
AX
SU
BR
ST
RS
BT
HA
SC
EL
IDX

IVIS (INFINITI VEHICLE IMMOBILIZER SYSTEM — NATS)

Trouble Diagnoses (Cont'd)

3	CHECK IGN SW. ON SIGNAL		
<p>1. Turn ignition switch ON. 2. Check voltage between terminal 7 of IMMU and ground with CONSULT-II or tester.</p>			
<p>Battery voltage should exist.</p>			
<p>SEL303WF</p>			
<p>OK or NG</p>			
OK	▶	GO TO 4.	
NG	▶	<p>Check the following</p> <ul style="list-style-type: none"> ● 10A fuse [No. 16, located in the fuse block (J/B)] ● Harness for open or short between fuse and IMMU connector <p>Ref. part No. C2</p>	

4	CHECK GROUND CIRCUIT FOR IMMU		
<p>1. Turn ignition OFF. 2. Check harness continuity between IMMU terminal 4 and ground.</p>			
<p>Continuity should exist.</p>			
<p>SEL304WD</p>			
<p>OK or NG</p>			
OK	▶	GO TO 5.	
NG	▶	Repair harness. Ref. part No. C3	

IVIS (INFINITI VEHICLE IMMOBILIZER SYSTEM — NATS)

Trouble Diagnoses (Cont'd)

5	CHECK COMMUNICATION LINE OPEN CIRCUIT	
<p>1. Disconnect ECM connector. 2. Check harness continuity between ECM terminal 116 and IMMU terminal 1.</p>		
<p style="text-align: right;">Continuity should exist.</p> <p style="text-align: right;">SEL305WD</p>		
OK or NG		
OK	▶	GO TO 6.
NG	▶	Repair harness or connector. Ref. part No. C4

6	CHECK COMMUNICATION LINE BATTERY SHORT CIRCUIT	
<p>1. Turn ignition ON. 2. Check voltage between ECM terminal 116 or IMMU terminal 1 and ground.</p>		
<p style="text-align: right;">Voltage: 0V</p> <p style="text-align: right;">SEL306WD</p>		
OK or NG		
OK	▶	GO TO 7.
NG	▶	Communication line is short-circuited with battery voltage line or ignition switch ON line. Repair harness or connectors. Ref. part No. C4

GI
MA
EM
LC
EC
FE
AT
TF
PD
AX
SU
BR
ST
RS
BT
HA
SC
EL
IDX

IVIS (INFINITI VEHICLE IMMOBILIZER SYSTEM — NATS)

Trouble Diagnoses (Cont'd)

7	CHECK COMMUNICATION LINE GROUND SHORT CIRCUIT	
<p>1. Turn ignition switch OFF. 2. Check continuity between ECM terminal 116 or IMMU terminal 1 and ground.</p>		
<p style="text-align: right;">Continuity should not exist.</p>		
OK or NG		
OK	▶	GO TO 8.
NG	▶	Communication line is short-circuited with ground line. Repair harness or connectors. Ref. part No. C4

SEL307WD

8	SIGNAL FROM ECM TO IMMU CHECK	
<p>1. Check the signal between ECM terminal 116 and ground with CONSULT-II or oscilloscope when ignition switch is turned "ON". 2. Make sure signals which are shown in the figure below can be detected during 750 msec. just after ignition switch is turned "ON".</p>		
OK or NG		
OK	▶	IMMU is malfunctioning. Replace IMMU. Ref. part No. A Perform initialization with CONSULT-II. For the operation of initialization, refer to "CONSULT-II Operation Manual IVIS/NVIS".
NG	▶	ECM is malfunctioning. Replace ECM. Ref. part No. B Perform initialization with CONSULT-II. For the operation of initialization, refer to "CONSULT-II Operation Manual IVIS/NVIS".

SEL730W

IVIS (INFINITI VEHICLE IMMOBILIZER SYSTEM — NATS)

Trouble Diagnoses (Cont'd)

DIAGNOSTIC PROCEDURE 3

=NBEL0224S07

Self-diagnostic results:
 “DIFFERENCE OF KEY” displayed on CONSULT-II screen

1	CONFIRM SELF-DIAGNOSTIC RESULTS											
Confirm SELF-DIAGNOSTIC RESULTS “DIFFERENCE OF KEY” displayed on CONSULT-II screen.												
<table border="1"> <thead> <tr> <th colspan="2">SELF DIAG RESULTS</th> </tr> <tr> <th>DTC RESULTS</th> <th>TIME</th> </tr> </thead> <tbody> <tr> <td>DIFFERENCE OF KEY</td> <td>0</td> </tr> <tr> <td> </td> <td> </td> </tr> <tr> <td> </td> <td> </td> </tr> </tbody> </table>			SELF DIAG RESULTS		DTC RESULTS	TIME	DIFFERENCE OF KEY	0				
SELF DIAG RESULTS												
DTC RESULTS	TIME											
DIFFERENCE OF KEY	0											
SEL367X												
Is CONSULT-II screen displayed as above?												
Yes	▶	GO TO 2.										
No	▶	GO TO SYMPTOM MATRIX CHART 1.										

2	PERFORM INITIALIZATION WITH CONSULT-II				
Perform initialization with CONSULT-II. Re-register all IVIS (NATS) ignition key IDs. For initialization and registration of IVIS (NATS) ignition key IDs, refer to “CONSULT-II operation manual IVIS/NVIS”.					
<table border="1"> <thead> <tr> <th>IMMU INITIALIZATION</th> </tr> </thead> <tbody> <tr> <td style="text-align: center;">INITIALIZATION FAIL</td> </tr> <tr> <td>THEN IGN KEY SW ‘OFF’ AND ‘ON’, AFTER CONFIRMING SELF-DIAG AND PASSWORD, PERFORM C/U INITIALIZATION AGAIN.</td> </tr> </tbody> </table>			IMMU INITIALIZATION	INITIALIZATION FAIL	THEN IGN KEY SW ‘OFF’ AND ‘ON’, AFTER CONFIRMING SELF-DIAG AND PASSWORD, PERFORM C/U INITIALIZATION AGAIN.
IMMU INITIALIZATION					
INITIALIZATION FAIL					
THEN IGN KEY SW ‘OFF’ AND ‘ON’, AFTER CONFIRMING SELF-DIAG AND PASSWORD, PERFORM C/U INITIALIZATION AGAIN.					
SEL297W					
NOTE: If the initialization is not completed or fails, CONSULT-II shows above message on the screen.					
Can the system be initialized and can the engine be started with re-registered IVIS (NATS) ignition key?					
Yes	▶	Ignition key ID was unregistered. Ref. part No. D			
No	▶	IMMU is malfunctioning. Replace IMMU. Ref. part No. A Perform initialization with CONSULT-II. For initialization, refer to “CONSULT-II operation manual IVIS/NVIS”.			

GI
MA
EM
LC
EC
FE
AT
TF
PD
AX
SU
BR
ST
RS
BT
HA
SC
EL
IDX

IVIS (INFINITI VEHICLE IMMOBILIZER SYSTEM — NATS)

Trouble Diagnoses (Cont'd)

DIAGNOSTIC PROCEDURE 4

=NBEL0224S08

Self-diagnostic results:

“CHAIN OF IMMU-KEY” displayed on CONSULT-II screen

1	CONFIRM SELF-DIAGNOSTIC RESULTS											
Confirm SELF-DIAGNOSTIC RESULTS “CHAIN OF IMMU-KEY” displayed on CONSULT-II screen.												
<table border="1"> <thead> <tr> <th colspan="2">SELF DIAG RESULTS</th> </tr> <tr> <th>DTC RESULTS</th> <th>TIME</th> </tr> </thead> <tbody> <tr> <td>CHAIN OF IMMU-KEY</td> <td>0</td> </tr> <tr> <td> </td> <td> </td> </tr> <tr> <td> </td> <td> </td> </tr> </tbody> </table>			SELF DIAG RESULTS		DTC RESULTS	TIME	CHAIN OF IMMU-KEY	0				
SELF DIAG RESULTS												
DTC RESULTS	TIME											
CHAIN OF IMMU-KEY	0											
SEL368X												
Is CONSULT-II screen displayed as above?												
Yes	▶	GO TO 2.										
No	▶	GO TO SYMPTOM MATRIX CHART 1.										

2	CHECK IVIS (NATS) IGNITION KEY ID CHIP	
Start engine with another registered IVIS (NATS) ignition key.		
Does the engine start?		
Yes	▶	Ignition key ID chip is malfunctioning. Replace the ignition key. Ref. part No. E Perform initialization with CONSULT-II. For initialization, refer to “CONSULT-II Operation Manual IVIS/NVIS”.
No	▶	GO TO 3.

3	CHECK IMMU INSTALLATION	
Check IMMU installation. Refer to “How to Replace IMMU” in EL-347.		
OK or NG		
OK	▶	IMMU is malfunctioning. Replace IMMU. Ref. part No. A Perform initialization with CONSULT-II. For initialization, refer to “CONSULT-II Operation Manual IVIS/NVIS”.
NG	▶	Reinstall IMMU correctly.

IVIS (INFINITI VEHICLE IMMOBILIZER SYSTEM — NATS)

Trouble Diagnoses (Cont'd)

DIAGNOSTIC PROCEDURE 5

=NBEL0224S09

Self-diagnostic results:
"ID DISCORD, IMM-ECM" displayed on CONSULT-II screen

1	CONFIRM SELF-DIAGNOSTIC RESULTS											
Confirm SELF-DIAGNOSTIC RESULTS "ID DISCORD, IMM-ECM" displayed on CONSULT-II screen.												
<table border="1" style="margin: auto; border-collapse: collapse;"> <thead> <tr> <th colspan="2">SELF DIAG RESULTS</th> </tr> <tr> <th>DTC RESULTS</th> <th>TIME</th> </tr> </thead> <tbody> <tr> <td>ID DISCORD, IMM-ECM</td> <td style="text-align: center;">0</td> </tr> <tr> <td> </td> <td> </td> </tr> <tr> <td> </td> <td> </td> </tr> </tbody> </table>			SELF DIAG RESULTS		DTC RESULTS	TIME	ID DISCORD, IMM-ECM	0				
SELF DIAG RESULTS												
DTC RESULTS	TIME											
ID DISCORD, IMM-ECM	0											
SEL369X												
<p>NOTE: "ID DISCORD IMM-ECM": Registered ID of IMMU is in discord with that of ECM.</p> <p style="text-align: center;">Is CONSULT-II screen displayed as above?</p>												
Yes	▶	GO TO 2.										
No	▶	GO TO SYMPTOM MATRIX CHART 1.										

2	PERFORM INITIALIZATION WITH CONSULT-II				
Perform initialization with CONSULT-II. Re-register all IVIS (NATS) ignition key IDs. For initialization, refer to "CONSULT-II operation manual IVIS/NVIS".					
<table border="1" style="margin: auto; border-collapse: collapse;"> <thead> <tr> <th>IMMU INITIALIZATION</th> </tr> </thead> <tbody> <tr> <td style="text-align: center; padding: 10px;"> INITIALIZATION FAIL </td> </tr> <tr> <td style="text-align: center; padding: 5px;"> THEN IGN KEY SW 'OFF' AND 'ON', AFTER CONFIRMING SELF-DIAG AND PASSWORD, PERFORM C/U INITIALIZATION AGAIN. </td> </tr> </tbody> </table>			IMMU INITIALIZATION	INITIALIZATION FAIL	THEN IGN KEY SW 'OFF' AND 'ON', AFTER CONFIRMING SELF-DIAG AND PASSWORD, PERFORM C/U INITIALIZATION AGAIN.
IMMU INITIALIZATION					
INITIALIZATION FAIL					
THEN IGN KEY SW 'OFF' AND 'ON', AFTER CONFIRMING SELF-DIAG AND PASSWORD, PERFORM C/U INITIALIZATION AGAIN.					
SEL297W					
<p>NOTE: If the initialization is not completed or fails, CONSULT-II shows above message on the screen.</p> <p style="text-align: center;">Can the system be initialized?</p>					
Yes	▶	Start engine. (END) (System initialization had not been completed. Ref. part No. F)			
No	▶	ECM is malfunctioning. Replace ECM. Ref. part No. F Perform initialization with CONSULT-II. For initialization, refer to "CONSULT-II operation manual IVIS/NVIS".			

GI
MA
EM
LC
EC
FE
AT
TF
PD
AX
SU
BR
ST
RS
BT
HA
SC
EL
IDX

IVIS (INFINITI VEHICLE IMMOBILIZER SYSTEM — NATS)

Trouble Diagnoses (Cont'd)

DIAGNOSTIC PROCEDURE 6 “SECURITY INDICATOR LAMP DOES NOT LIGHT UP”

=NBEL0224S10

1	CHECK FUSE	
Check 10A fuse [No. 12, located in the fuse block (J/B)].		
Is 10A fuse OK?		
Yes	▶	GO TO 2.
No	▶	Replace fuse.

2	CHECK SECURITY INDICATOR LAMP	
<ol style="list-style-type: none"> 1. Install 10A fuse. 2. Perform initialization with CONSULT-II. For initialization, refer to “CONSULT-II Operation Manual IVIS/NVIS”. 3. Turn ignition switch OFF. 4. Start engine and turn ignition switch OFF. 5. Check the security indicator lamp lighting. Security indicator lamp should be blinking.		
OK or NG		
OK	▶	INSPECTION END
NG	▶	GO TO 3.

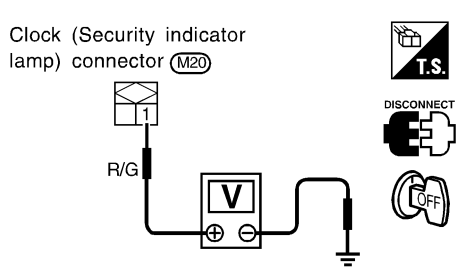
3	CHECK SECURITY INDICATOR LAMP POWER SUPPLY CIRCUIT	
<ol style="list-style-type: none"> 1. Disconnect security indicator lamp connector. 2. Check voltage between security indicator lamp connector terminal 1 and ground. 		
		
Battery voltage should exist.		
SEL370X		
OK or NG		
OK	▶	GO TO 4.
NG	▶	Check harness for open or short between fuse and security indicator lamp.

4	CHECK SECURITY INDICATOR LAMP	
Check security Indicator Lamp.		
Is security indicator lamp OK?		
Yes	▶	GO TO 5.
No	▶	Replace security indicator lamp.

IVIS (INFINITI VEHICLE IMMOBILIZER SYSTEM — NATS)

Trouble Diagnoses (Cont'd)

5	CHECK IMMU FUNCTION	
	<p>1. Connect IMMU connector.</p> <p>2. Disconnect security indicator lamp connector.</p> <p>3. Check continuity between IMMU terminal 5 and ground.</p> <div style="display: flex; justify-content: space-around; align-items: center;"> <div data-bbox="284 315 617 577"> <p>IMMU connector (E113)</p> <p>BR</p> </div> <div data-bbox="682 325 763 556"> <p>H.S.</p> <p>CONNECT</p> <p>OFF</p> </div> <div data-bbox="868 409 1347 451"> <p>Continuity should exist intermittently.</p> </div> </div> <p style="text-align: right;">SEL300WC</p> <p style="text-align: center;">OK or NG</p>	
OK	▶	Check harness for open or short between security indicator lamp and IMMU.
NG	▶	<p>IMMU is malfunctioning.</p> <p>Replace IMMU.</p> <p>Perform initialization with CONSULT-II.</p> <p>For initialization, refer to "CONSULT-II operation manual IVIS/NVIS".</p>

GI
MA
EM
LC
EC
FE
AT
TF
PD
AX
SU
BR
ST
RS
BT
HA
SC
EL
IDX

IVIS (INFINITI VEHICLE IMMOBILIZER SYSTEM — NATS)

Trouble Diagnoses (Cont'd)

DIAGNOSTIC PROCEDURE 7

=NBEL0224S11

Self-diagnostic results:
"LOCK MODE" displayed on CONSULT-II screen

1	CONFIRM SELF-DIAGNOSTIC RESULTS											
Confirm SELF-DIAGNOSTIC RESULTS "LOCK MODE" is displayed on CONSULT-II screen.												
<table border="1"> <thead> <tr> <th colspan="2">SELF DIAG RESULTS</th> </tr> <tr> <th>DTC RESULTS</th> <th>TIME</th> </tr> </thead> <tbody> <tr> <td style="text-align: center;">LOCK MODE</td> <td style="text-align: center;">0</td> </tr> <tr> <td> </td> <td> </td> </tr> <tr> <td> </td> <td> </td> </tr> </tbody> </table>			SELF DIAG RESULTS		DTC RESULTS	TIME	LOCK MODE	0				
SELF DIAG RESULTS												
DTC RESULTS	TIME											
LOCK MODE	0											
SEL371X												
Is CONSULT-II screen displayed as above?												
Yes	▶	GO TO 2.										
No	▶	GO TO SYMPTOM MATRIX CHART 1.										

2	ESCAPE FROM LOCK MODE	
<ol style="list-style-type: none"> 1. Turn ignition switch OFF. 2. Turn ignition switch ON with registered key. (Do not start engine.) Wait 5 seconds. 3. Return the key to OFF position. 4. Repeat steps 2 and 3 twice (total of three cycles). 5. Start the engine. 		
Does engine start?		
Yes	▶	System is OK. (Now system is escaped from "LOCK MODE".)
No	▶	GO TO 3.

3	CHECK IMMU ILLUSTRATION	
Check IMMU installation. Refer to "How to Replace IMMU" in EL-347.		
OK or NG		
OK	▶	GO TO 4.
NG	▶	Reinstall IMMU correctly.

IVIS (INFINITI VEHICLE IMMOBILIZER SYSTEM — NATS)

Trouble Diagnoses (Cont'd)

4	PERFORM INITIALIZATION WITH CONSULT-II	
<p>Perform initialization with CONSULT-II. For initialization, refer to "CONSULT-II operation manual IVIS/NVIS".</p> <div style="border: 1px solid black; padding: 5px; margin: 10px auto; width: fit-content;"> <p style="text-align: center; margin: 0;">IMMU INITIALIZATION</p> <hr/> <p style="text-align: center; margin: 0;">INITIALIZATION FAIL</p> <hr/> <p style="text-align: center; margin: 0; font-size: small;">THEN IGN KEY SW 'OFF' AND 'ON', AFTER CONFIRMING SELF-DIAG AND PASSWORD, PERFORM C/U INITIALIZATION AGAIN.</p> </div> <p style="text-align: right; margin-top: 20px;">SEL297W</p>		
<p>NOTE: If the initialization is not completed or fails, CONSULT-II shows the above message on the screen.</p> <p style="text-align: center;">Can the system be initialized?</p>		
Yes	▶	System is OK.
No	▶	GO TO DIAGNOSTIC PROCEDURE 4 to check "CHAIN OF IMMU-KEY", refer to EL-342.

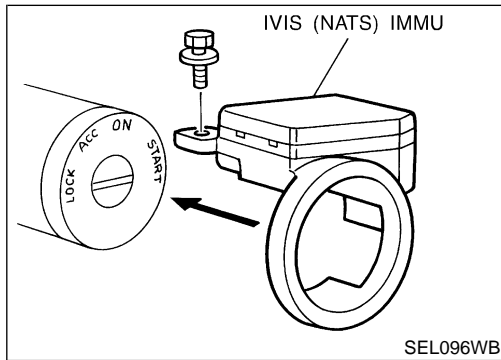

How to Replace IVIS (NATS) IMMU

NBEL0225

NOTE:

- If IVIS (NATS) IMMU is not installed correctly, IVIS (NATS) system will not operate properly and SELF-DIAG RESULTS on CONSULT-II screen will show "LOCK MODE".

GI
MA
EM
LC
EC
FE
AT
TF
PD
AX
SU
BR
ST
RS
BT
HA
SC
EL
IDX

INFINITI COMMUNICATOR (IVCS)

Precaution

Precaution

NBEL0177

CAUTION:

- Use CONSULT-II to set the system “Demonstration mode” if INFINITI Communicator needs to be activated during service procedures. (For details of the demonstration mode, refer to EL-379.)
- Make sure to turn the demonstration mode OFF before returning the vehicle to the owner.
- In the demonstration mode, no service from the Communicator Response Center is available. Therefore, even if the customer encounters an emergency, no service will be dispatched.
- If the theft warning system is activated for more than 7 seconds, INFINITI Communicator will dial to the Communicator Response Center automatically. The operator will contact the customer to confirm whether the vehicle has been stolen or not.
- When “Mayday” emergency dialing is activated (if the system is not in the demonstration mode), the Communicator Response Center operator will come online. If there is no emergency, the operator will ask the occupant for the user password (option). Failure to provide the correct password results in a police response.
- IVCS unit memory includes VIN (Vehicle Identification Number) and other such vehicle specific data. Therefore, the IVCS unit cannot be transferred to another vehicle. When the IVCS unit is replaced, the new unit must be set up and programmed. The INFINITI Communicator system automatically contacts the Communicator Response Center the first time the vehicle is started after a phone number has been changed or a module (IVCS unit) is replaced. The VIN will be written in the memory of the new unit by transmitting data from the Communicator Response Center. For details, refer to “System Setting”, EL-381.
- Before servicing the vehicle, confirm that the VIN memorized by the IVCS unit is the same as the VIN on the vehicle’s identification plate.

Communicator Response Center Telephone Number for Technicians

NBEL0178

The Communicator Response Center telephone number for technicians is **1-888-427-4812**.

Whenever an INFINITI dealer technician dials the above number, the following information will be required by the Communicator Response Center operator.

- Customer name
- Unit ID number of old IVCS unit (For details, refer to EL-367.)
- Unit ID number of new IVCS unit
- VIN
- Dealer name and code (For security purposes)
- Dealer contact person (technician)
- Dealer phone and fax numbers

INFINITI COMMUNICATOR (IVCS)

Component Parts and Harness Connector Location

Component Parts and Harness Connector Location

NBEL0179

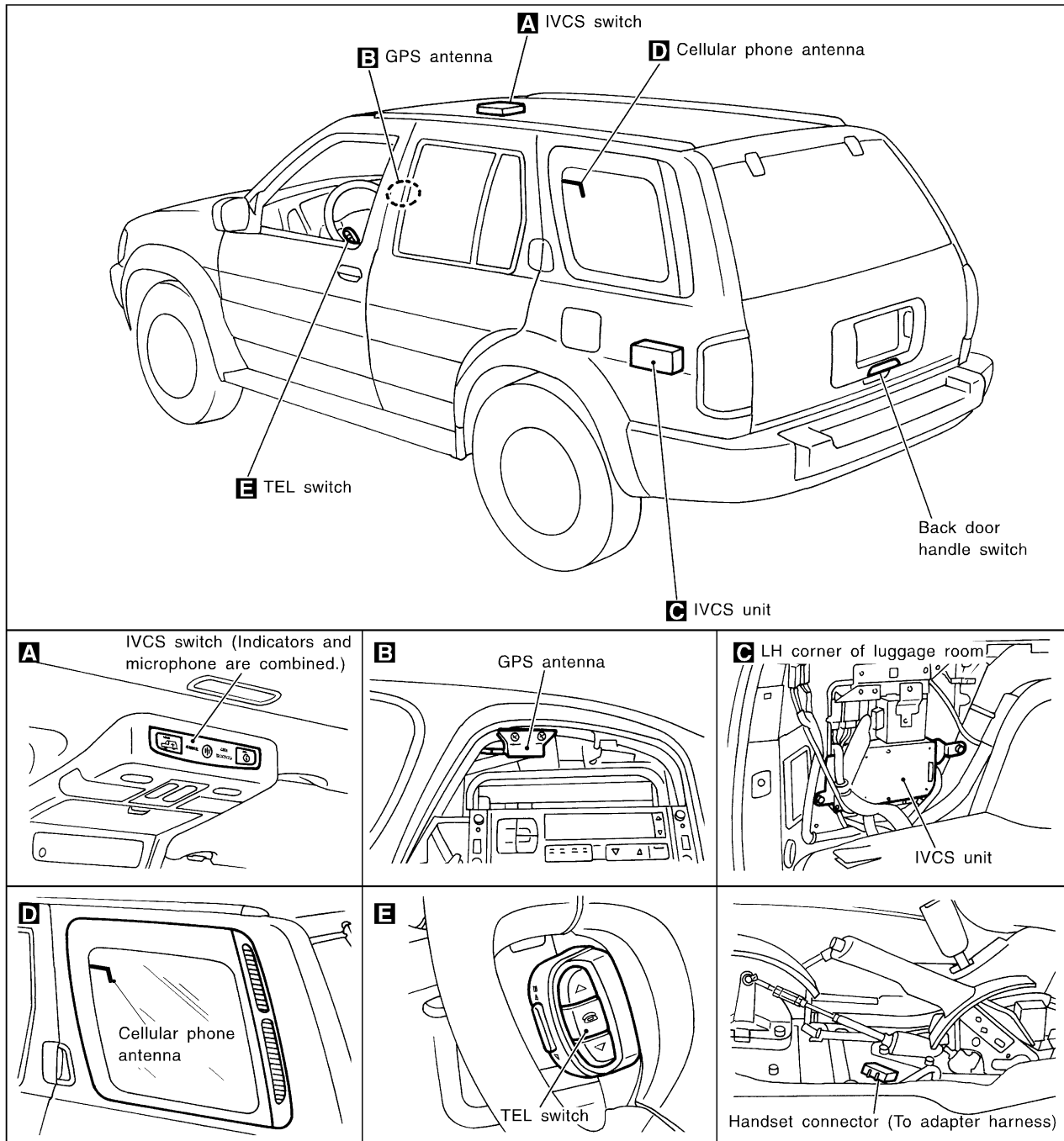

GI

MA

EM

LC

EC

FE

AT

TF

PD

AX

SU

BR

ST

RS

BT

HA

SC

EL

IDX

SEL098W

INFINITI COMMUNICATOR (IVCS)

System Description

NBEL0180

OUTLINE

NBEL0180S01

INFINITI Communicator system uses the Global Positioning System (GPS), cellular phone technology and the Communicator Response Center to provide the following functions.

- One touch "Information" dialing
- One touch "Mayday" emergency dialing
- Automatic air bag inflation notification
- Stolen vehicle tracking
- Alarm notification
- Remote door unlock

There are limitations to the INFINITI Communicator system. To understand the system, read SYSTEM LIMITATIONS (EL-351) thoroughly.

SYSTEM COMPOSITION

NBEL0180S02

- The INFINITI Communicator system is controlled by the IVCS (In Vehicle Communication System) unit. System status ("Mayday"-emergency dialing, or re-dialing, etc.) is displayed by the indicators in the IVCS switch.
- The INFINITI Communicator system can only make calls to the Communicator Response Center and receive calls from the center, unless the customer chooses to have the optional handset install.

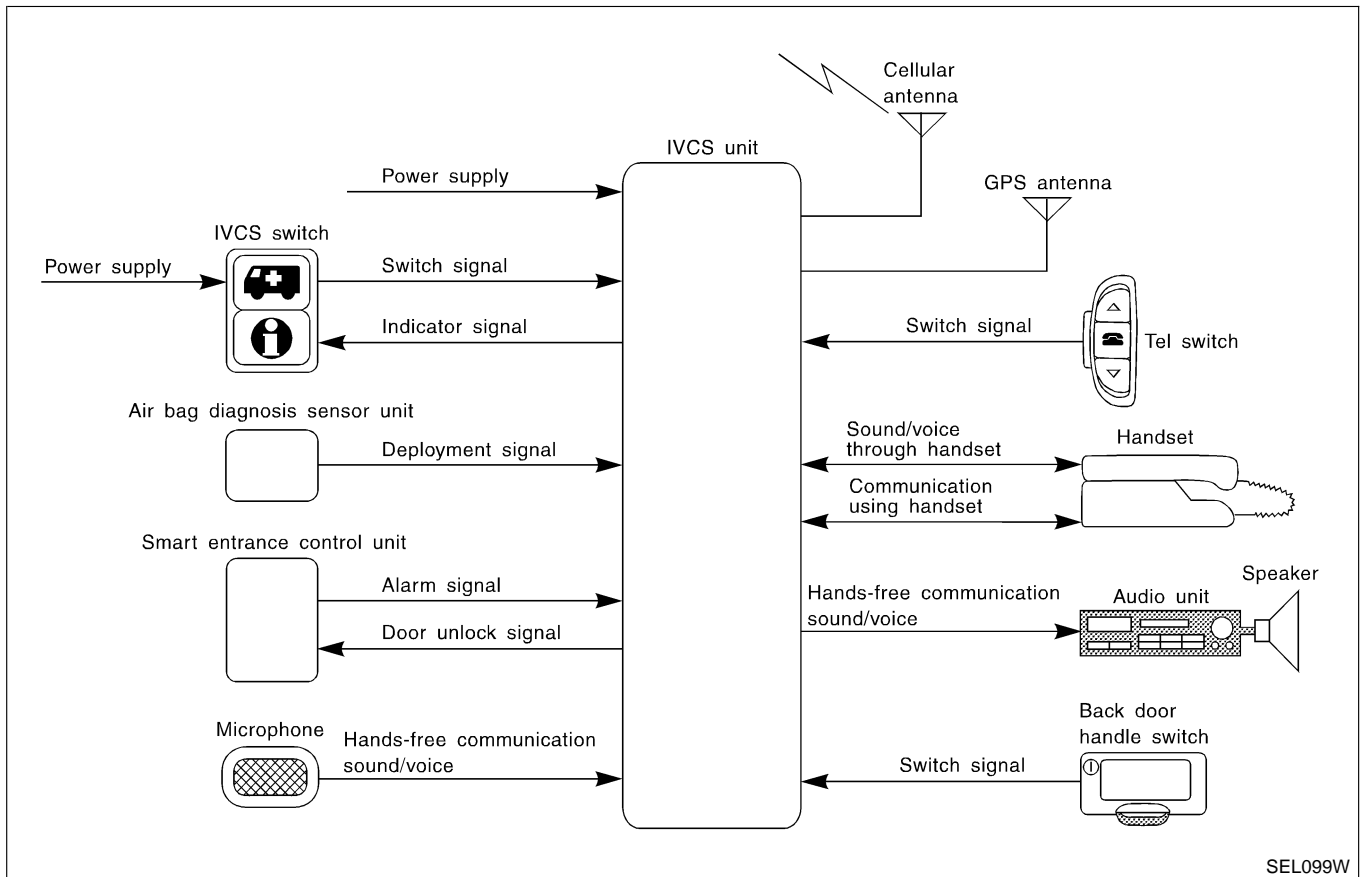

SYSTEM LIMITATIONS

Service Area

NBEL0180S03

Depending on the cellular provider chosen, service is provided in the 48 contiguous states. Service is not available in Alaska, Hawaii, Canada, or Mexico. The Communicator Response Center will not be able to locate the customer's vehicle outside of the continental United States.

GI

MA

Inoperative if Cellular Phone is Inactive or Inoperative

NBEL0180S0302

INFINITI Communicator will be inoperative if the customer does not have an active account with cellular provider, since INFINITI Communicator relies on the cellular network. When the INFINITI Communicator system is outside of cellular service, the "NO SERVICE" indicator will illuminate. If you try to activate INFINITI Communicator, the REQUEST will be cancelled. Cellular phone transmission may become temporarily disabled, or interrupted by environmental factors like tunnels, bridges, or tall buildings. In such cases, INFINITI Communicator will re-dial up to four times. After several failed attempts, the system will quit dialing and return to normal mode.

EM

LC

EC

FE

AT

Inoperative if The System is in The Demonstration Mode

NBEL0180S0303

The INFINITI Communicator system remains in the demonstration mode until the setup procedures are completed. If the system is activated in this mode, the Communicator Response Center will recognize this operation as a demonstration and will not provide any service. The system can be changed to the demonstration mode by using CONSULT-II to check the system operation. Do not forget to turn off the demonstration mode after confirmation.

TF

PD

AX

Battery

NBEL0180S0304

Since INFINITI Communicator is powered by the vehicle's battery, if the battery is removed, damaged or discharged, the system will not work.

SU

BR

Inoperative if Cellular System is Busy

NBEL0180S0305

When INFINITI Communicator tries to contact the Communicator Response Center, but the cellular network is busy, the system attempts to re-dial for up to two hours. This time varies greatly depending on the cellular network and cellular signal strength. The system resets to ready when the system completes the re-dialing attempts.

ST

RS

Roaming

NBEL0180S0306

If the customer's cellular provider does not have a roaming agreement with the provider where the vehicle locates, it may not be possible to use the lines of a different cellular provider. Therefore, it is impossible that INFINITI Communicator will contact the Communicator Response Center.

BT

HA

SC

Special Cellular Features

NBEL0180S0307

Some cellular carriers offer custom phone numbers that are assigned a Personal Identification Number (PIN). The cellular phone user is required to enter the PIN anytime a phone call is made. The INFINITI Communicator system is not compatible with the PIN feature. A PIN requirement on the cellular phone will cause the INFINITI Communicator system to be inoperative.

EL

IDX

Other special features such as call waiting, voice mail, call forwarding, etc. can interfere with INFINITI Communicator system operation.

Cellular Airwave Interference

NBEL0180S0308

At times someone other than the Communicator Response Center operator may be heard. This is caused by Cellular Airwave Interference and is not caused by an INFINITI Communicator system malfunction.

Possibility of Positioning Capability Degraded

NBEL0180S0309

Vehicle positioning is accomplished using the GPS (Global Positioning System). If the signal from the GPS satellite is obstructed by a tunnel or building, positioning capability may be degraded or lost. In this case, the last valid position obtained before the obstruction is transmitted to the Communicator Response Center. The precision is also influenced by the location of GPS satellites.

Once the battery cable is disconnected, it will take about 5 minutes to determine the vehicle location. This is because the memory related to GPS is lost when the battery cable is disconnected.

OPERATION

One Touch “Information” Dialing

NBEL0180S04

NBEL0180S0401

- If the vehicle becomes disabled due to problems such as engine trouble, press the “Information” switch to connect to the Communicator Response Center and receive the desired service.
- When the indicator lamp on the switch lights up, it means that the system has started to contact the Communicator Response Center. (Voice communication with Communicator Response Center operator is not available while DATA is being transmitted even if the indicator lamp is lit.)
- When the indicator lamp blinks, it means that the system is preparing for cellular connection or attempting to re-dial.

One Touch “Mayday” Emergency Dialing

NBEL0180S0402

- When an emergency occurs, press the “Mayday” emergency switch to connect to the Communicator Response Center. With this report, the Communicator Response Center recognizes that an emergency has occurred and provides necessary service.
- The operator will request a password (if the customer chooses to establish a password). If the wrong password or if no password is provided, the Communicator Response Center will assume the customer is in a duress situation and dispatch police.
- When no voice reply is heard from the vehicle or the sound heard indicates an emergency situation, the Communicator Response Center will have the police rush to the scene.
- Other operations are the same as service dialing.

Automatic Air Bag Inflation Notification

NBEL0180S0403

- When an air bag inflates, the air bag diagnosis sensor unit sends the air bag inflation signal to the IVCS unit, and the system automatically dials the Communicator Response Center to report the occurrence of an accident.

Stolen Vehicle Tracking

NBEL0180S0404

- When a vehicle is stolen, the owner can contact the Communicator Response Center to attempt to locate the stolen vehicle. The Communicator Response Center will activate the stolen vehicle tracking to locate the vehicle. If the Communicator Response Center successfully locates the vehicle, they will contact the police to provide the location.

- The vehicle location data is calculated using GPS.
- The vehicle ignition switch must be turned to the ON position to obtain the vehicle location. (This is because the system is in the sleep mode when the ignition switch is OFF.)
- Once this function starts up, regardless of the ignition switch position, the system keeps transmitting the vehicle location until the cancel signal is transmitted from the Communicator Response Center.
- While this function is operating, the operator can covertly monitor what is happening inside the vehicle through the hands-free microphone.

GI
MA
EM
LC

Alarm Notification

- When theft warning system sounds an alarm for more than 7 seconds because of improper access, the alarm signal is transmitted from the smart entrance control unit to the IVCS unit, and the system executes automatic dialing to the Communicator Response Center.
If the alarm is reset before 7 seconds has elapsed, the INFINITI Communicator will not place a call to the Communicator Response Center.
- This function operates regardless of ignition switch position.
- While this function is operating, the operator can covertly monitor what is happening inside the vehicle through the hands-free microphone.

EC
FE
AT
TF
PD

Remote Door Unlock

- When the door is locked with the key inside the vehicle, the door can be unlocked by contacting the Communicator Response Center. (Proof that the person calling is the owner must be received by the Communicator Response Center.)
- When the ignition key is in the "OFF" position, the system is in the sleep mode. Therefore, back door outside handle must be pulled to wake up the system.
- To perform remote door unlock, call the Communicator Response Center and follow the operator's instructions.

AX
SU
BR

NOTE:

- When the system contacts the Communicator Response Center, data including the vehicle location is transmitted to the Communicator Response Center.
- Communication with the Communicator Response Center is not completed until the completion signal is transmitted from the Communicator Response Center. (Any calls to the Communicator Response Center can only be terminated by Communicator Response Center.)
- Functions other than alarm notification and remote door unlock operate while the ignition switch is ON and only for three minutes after the switch is turned OFF.
- Once a call to the Communicator Response Center is made, the communication continues regardless of the ignition key switch position.
- All the voice communication with the Communicator Response Center is made through the hands-free telephone.
- When the INFINITI Communicator system is activated, the handset does not function.

ST
RS
BT
HA
SC
EL
IDX

INFINITI COMMUNICATOR (IVCS)

System Description (Cont'd)

DATA TRANSMITTING

NBEL0180S05

When contact to the Communicator Response Center is made, vehicle sends electrical data including type of activation (i.e., emergency call or alarm notification), vehicle location, time, etc.

SLEEP/WAKE UP CONTROL

NBEL0180S06

3 minutes after the ignition switch is turned OFF, the system goes into the SLEEP MODE to save battery power supply. Communication with Communicator Response Center is not available in the SLEEP MODE.

To wake up the system, perform either of the following operations.

- Turn Ignition switch ON.
- Pull back door outside handle for more than 10 seconds. (Operation for door unlock function)

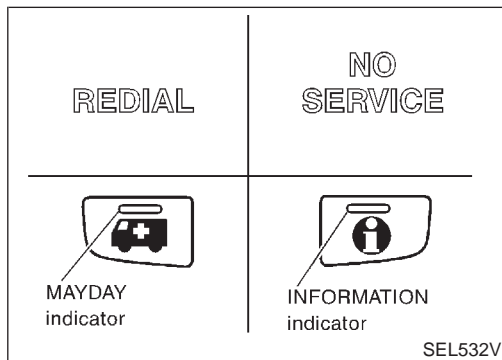

INDICATOR LAMPS OPERATION

NBEL0180S07

The system status is displayed as below by the indicator lamps.

Indicator	Condition	Description
MAYDAY	Blinks.	System is trying to acquire an available cellular channel by "Mayday" switch operation.
	Lights up. (See NOTE.)	System is connected to a cellular channel and is communicating information to the Communicator Response Center.
INFORMATION	Blinks.	System is trying to acquire an available cellular channel by "Information" switch operation.
	Lights up. (See NOTE.)	System is connected to a cellular channel and is communicating information to the Communicator Response Center.
REDIAL	Lights up.	Re-dialing
	Blinks.	Waiting for re-dial
NO SERVICE	Lights up.	Out of CELLULAR PHONE service area or signal is too weak.

NOTE:

- When connection to Communicator Response Center by re-dial ends in failure, all the indicators are turned off.
- All indicators illuminate for up to 30 seconds or more when ignition switch is turned from OFF to ON and the system performs a self check.
- If both of MAYDAY and INFORMATION indicators do not turn off 30 seconds or more after the ignition switch is turned to ON, the system is malfunctioning.

AUTOMATIC RE-DIAL/AUTO RESET TO READY

NBEL0180S08

- When INFINITI Communicator tries to contact the Communicator Response Center, but the cellular network is busy, the system attempts to dial for up to 2 hours. This time varies

greatly depending on the cellular network and cellular signal strength. The system resets to ready when the system completes the dialing attempts. The vehicle owner can press the button again if he or she still needs to contact the Communicator Response Center.

- INFINITI Communicator automatically redials if communication between the vehicle owner and Communicator Response Center is lost for some reason.
- The only way for a transmission to be officially terminated is for the Communicator Response Center to send an end transmission signal, which turns off the indicator in the switch. (Communication with Communicator Response Center can not be terminated by the occupant.)
- If the vehicle owner start the engine during a call, the conversation may be interrupted. When this happens the system may try to resume transmission once after the engine has been started.

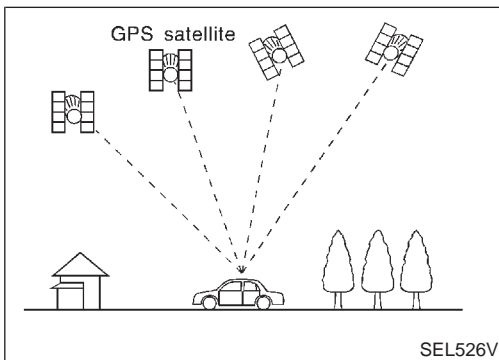

GPS (GLOBAL POSITIONING SYSTEM)

NBEL0180S09

GPS is the global positioning system developed and operated by the US Department of Defense. GPS satellites (NAVSTAR) transmit radio waves and orbit around the earth at an altitude of approximately 21,000 km (13,000 miles).

GPS receiver calculates the three-dimensional position of the vehicle (latitude, longitude, and altitude from the sea level) by the time difference of the radio wave arriving from more than four GPS satellites (three-dimensional positioning).

When the radio wave is received from only three GPS satellites, the two-dimensional position (latitude and longitude) is calculated, using the altitude from the sea level data calculated by using four GPS satellites (two-dimensional positioning).

Positioning capability is degraded in the following cases.

- In two-dimensional positioning, when the vehicle's altitude from the sea level changes, the precision becomes lower.
- The location detection performance can have an error of about 100 m (300 ft) even in three-dimensional positioning with high precision. Because the precision is influenced by the location of GPS satellites used for positioning, the location detection performance may drop depending on the location of GPS satellites.
- When the radio wave from GPS satellites cannot be received, for example, when the vehicle is in a tunnel, in a parking lot inside building, under an elevated superhighway or near strong power lines, the location may not be detected. Turbulent/electric weather conditions may also affect positioning performance. If something is placed on the antenna, the radio wave from GPS satellites may not be received.

GI
MA
EM
LC
EC
FE
AT
TF
PD
AX
SU
BR
ST
RS
BT
HA
SC
EL
IDX

INFINITI COMMUNICATOR (IVCS)

System Description (Cont'd)

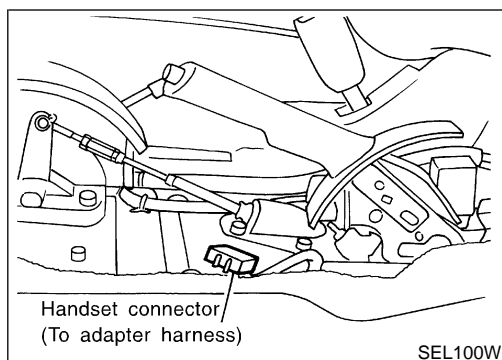

HANDSET

NBEL0180S10

NOTE:

- If an optional handset is installed, INFINITI Communicator can be used as a normal cellular phone.
- If INFINITI Communicator is activated when INFINITI Communicator system's cellular phone is in use, the current phone transmission will be cut and INFINITI Communicator will dial the Communicator Response Center. The cellular handset will be disabled, and communication with the Communicator Response Center operator will be carried out through the hands-free microphone.
- After communication with Communicator Response Center is finished, the handset last number memory will be erased.
- While INFINITI Communicator is activated, the handset becomes inoperative and all communication with the operator is accomplished via the hands-free phone. When an activation is terminated, the handset will be unlocked.

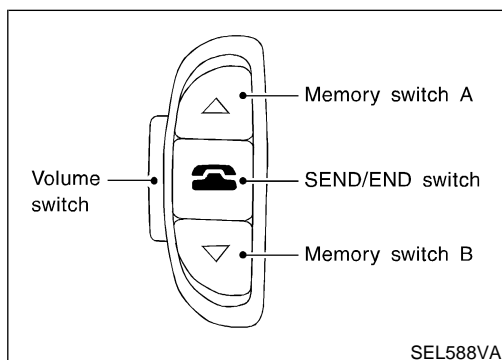

TEL SWITCH

NBEL0180S11

When any of the TEL switches is pressed, the TEL switch which is combined with the multiplex transmitting unit sends operational commands to the IVCS unit. TEL switch has following three functions.

- Volume adjust
- Placing re-dial call
- Placing memorized call (The telephone numbers are stored in the handset. A maximum of 6 memories are operative.)

VOLUME Switch

NBEL0180S1103

Voice volume from the front RH speaker can be adjusted by using the VOLUME switch.

SEND/END Switch Operation (Without Navigation System)

NBEL0180S1101

- When a call is received, press SEND/END switch to permit conversation.
- At the completion of the conversation, press the SEND/END switch to terminate the call.
- To re-dial the last phone number, press SEND/END switch.

MEMORY Switch Operation (Without Navigation System)

NBEL0180S1102

- A maximum of 6 telephone numbers which stored in the memory of the handset can be dialed by MEMORY switch operation.
- The last phone number is erased if the ignition switch is turned off or if the INFINITI Communicator system has been activated.
- For the procedure to input telephone numbers, refer to the handset operation manual.
- To select memory 1 to 6, push MEMORY switch A or B. Every push on the switch changes the memory as follows.
SWITCH A: Memory 1 → 2 → 3 → OFF
SWITCH B: Memory 4 → 5 → 6 → OFF

INFINITI COMMUNICATOR (IVCS)

System Description (Cont'd)

After selecting memory, push SEND/END switch to make a call.

NOTE:

Memory switches are not functional unless handset is installed.

GI

MA

EM

LC

EC

FE

AT

TF

PD

AX

SU

BR

ST

RS

BT

HA

SC

EL

IDX

INFINITI COMMUNICATOR (IVCS)

Schematic

Schematic

NBEL0181

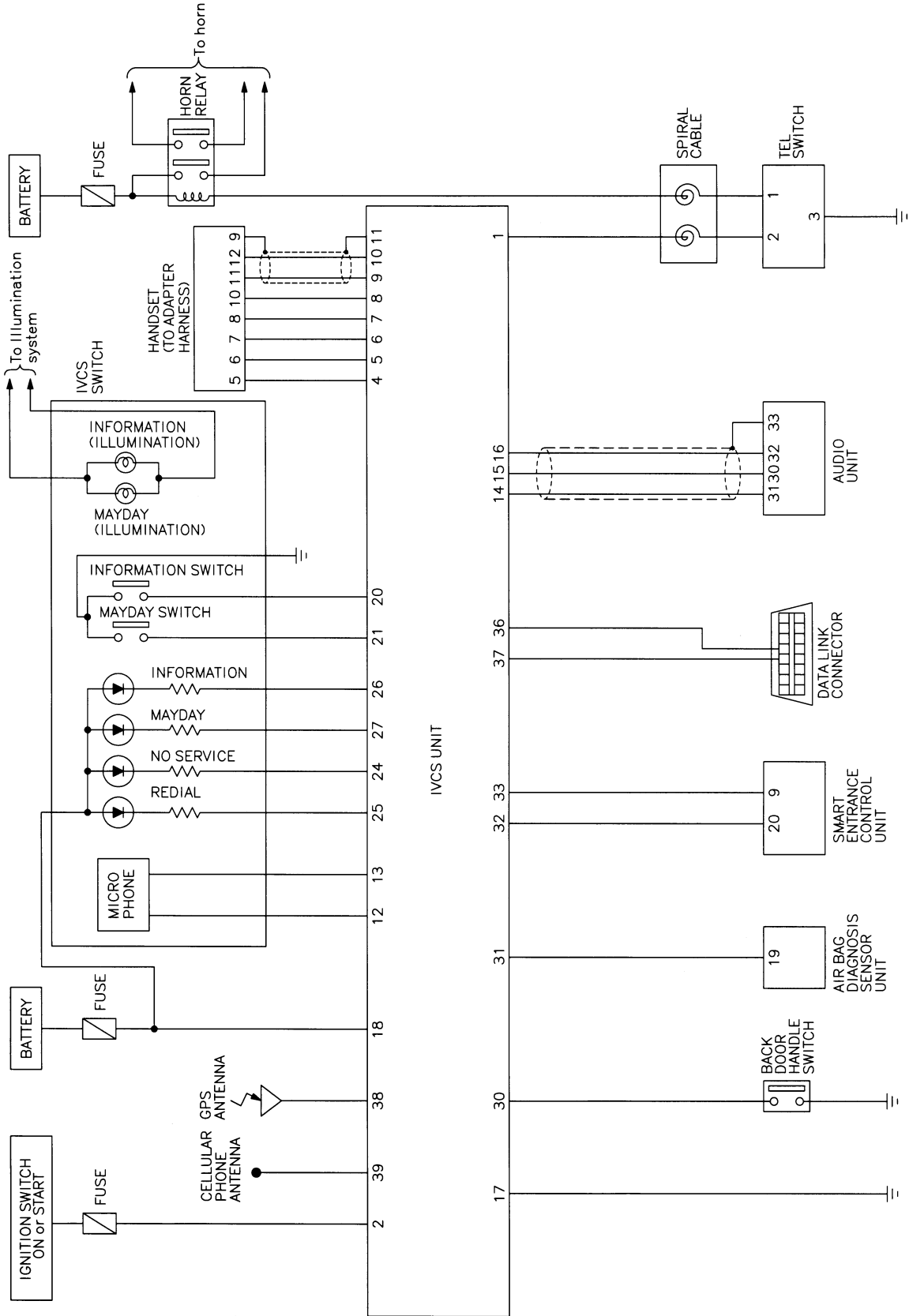

MEL867L

INFINITI COMMUNICATOR (IVCS)

Wiring Diagram — IVCS —

Wiring Diagram — IVCS —

NBEL0182

EL-IVCS-01

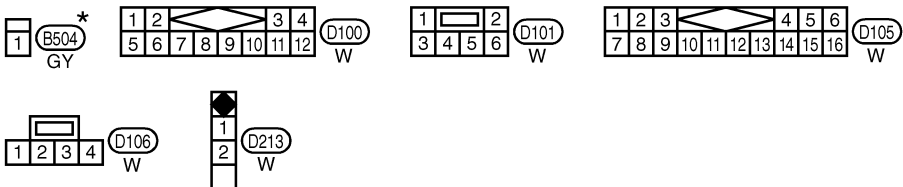
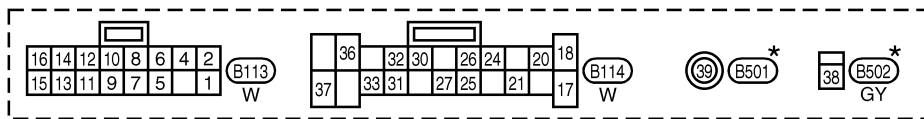
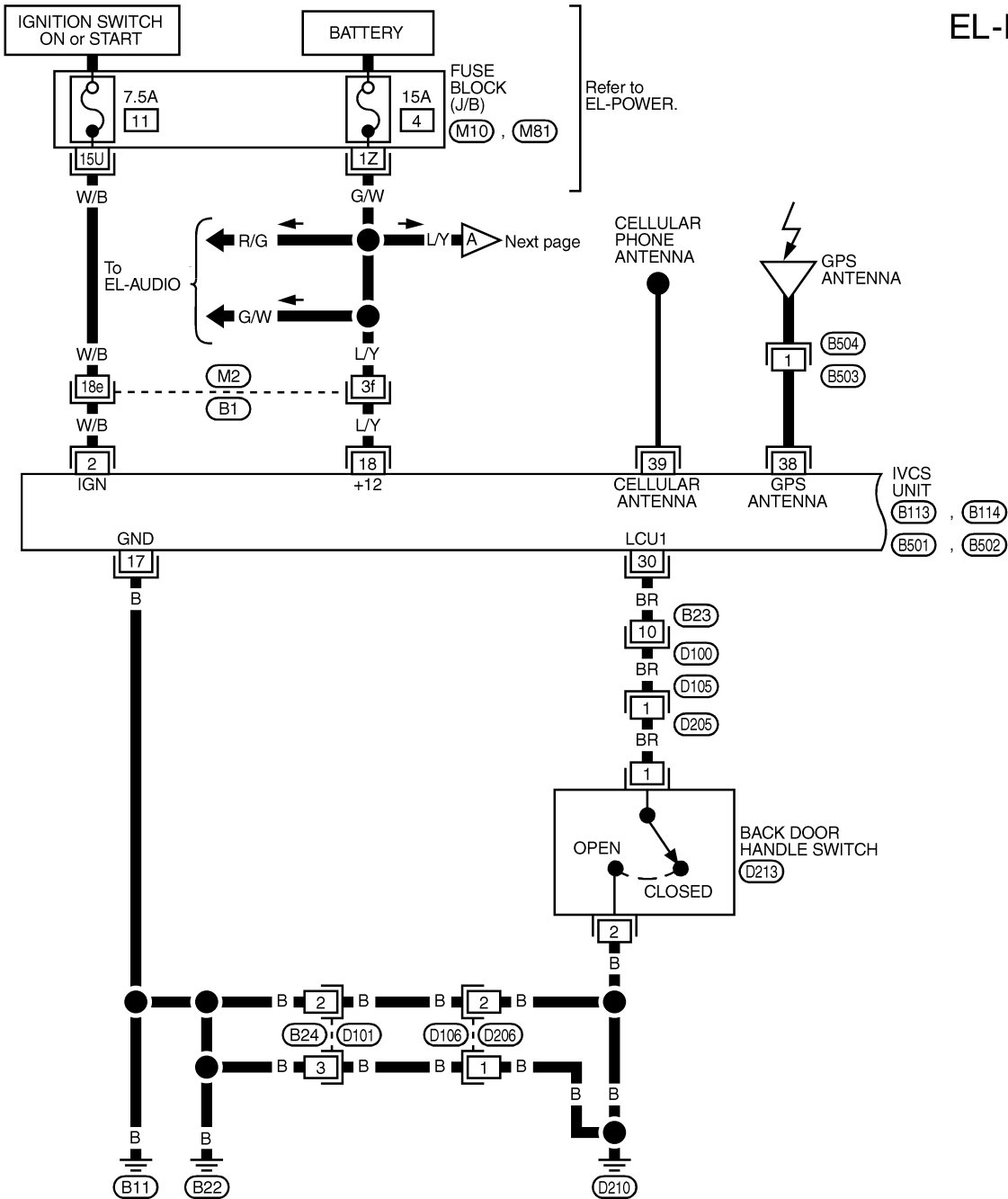

REFER TO THE FOLLOWING.

(B1) - SUPER MULTIPLE

JUNCTION (SMJ)

(M10), (M81) - FUSE BLOCK -

JUNCTION BOX (J/B)

* : This connector is not shown in "HARNESS LAYOUT", EL section.

GI
MA
EM
LC
EC
FE
AT
TF
PD
AX
SU
BR
ST
RS
BT
HA
SC
EL
IDX

MEL868L

INFINITI COMMUNICATOR (IVCS)

Wiring Diagram — IVCS — (Cont'd)

EL-IVCS-02

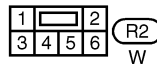
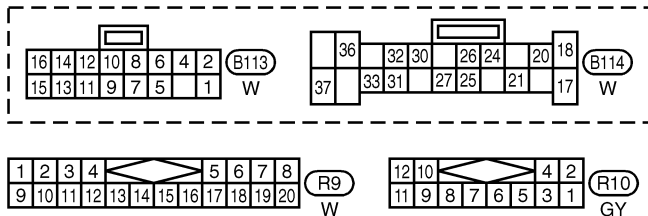
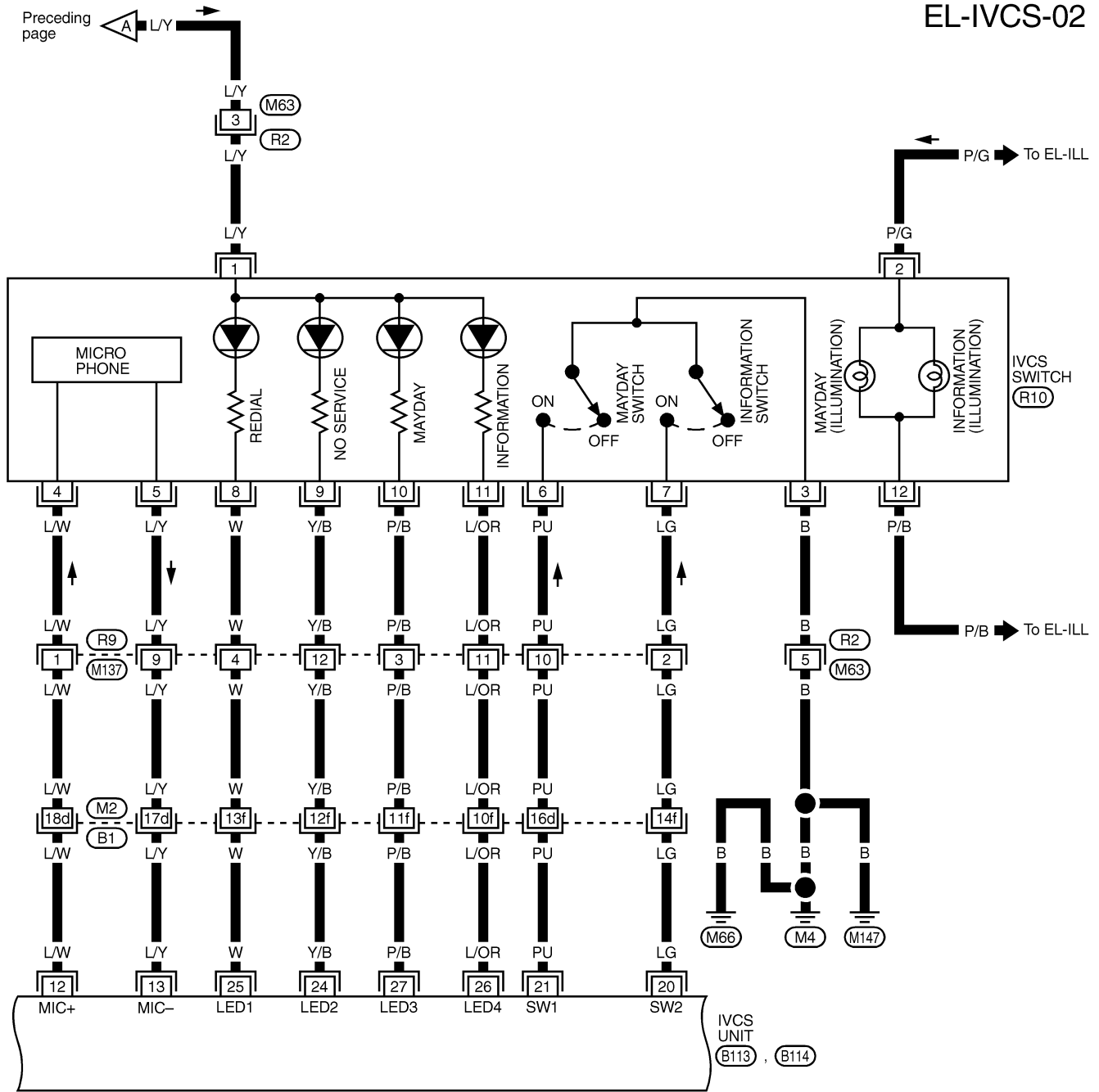

REFER TO THE FOLLOWING.

(B1) - SUPER MULTIPLE JUNCTION (SMJ)

MEL869L

INFINITI COMMUNICATOR (IVCS)

Wiring Diagram — IVCS — (Cont'd)

EL-IVCS-03

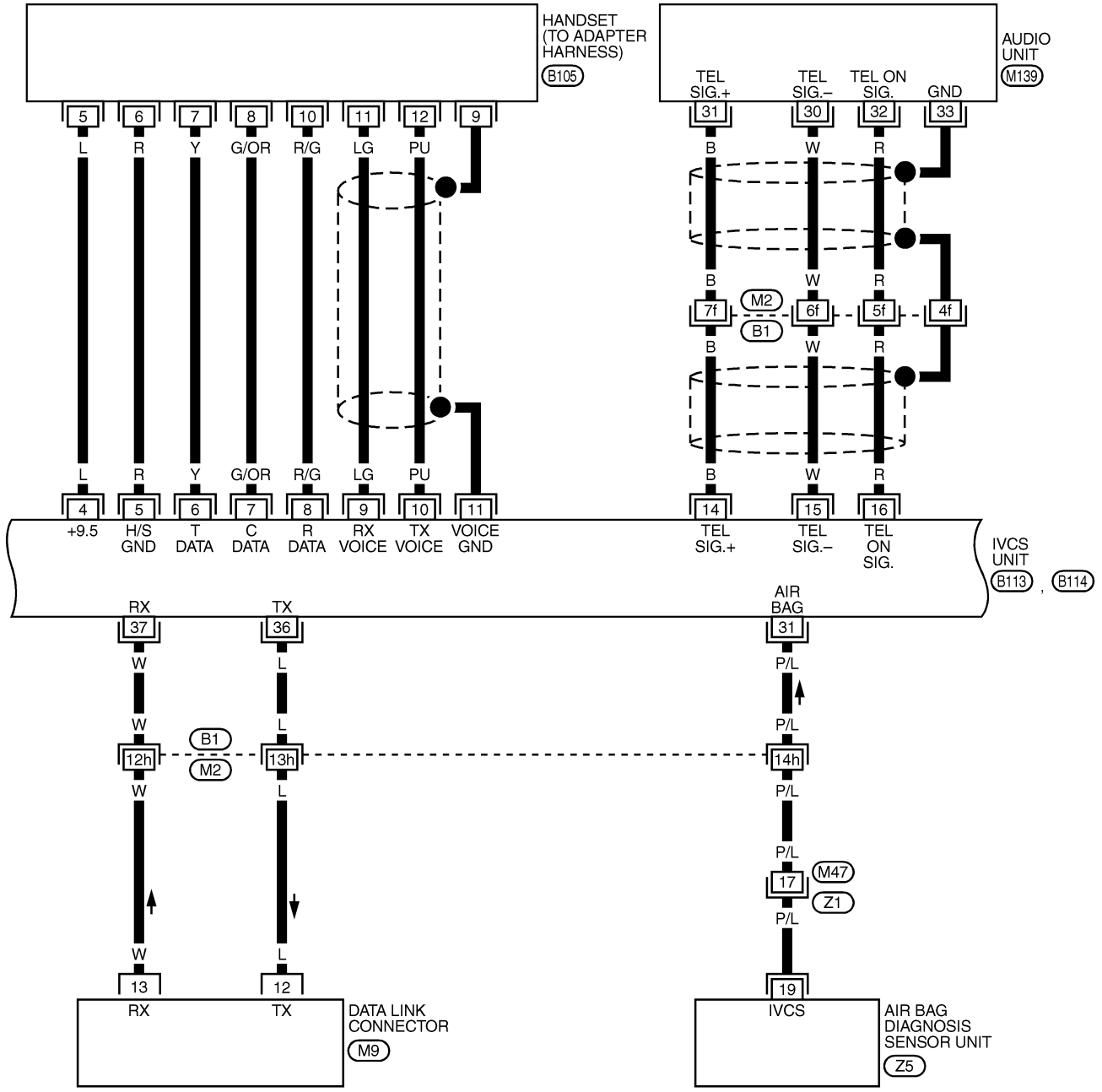

GI
MA
EM
LC
EC
FE
AT
TF
PD
AX
SU
BR
ST
RS
BT
HA
SC
EL
IDX

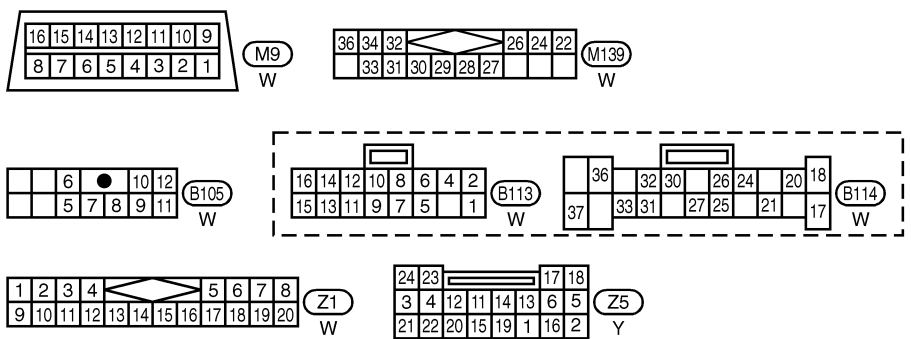

REFER TO THE FOLLOWING
(B1) -SUPER MULTIPLE
JUNCTION (SMJ)

MEL870L

INFINITI COMMUNICATOR (IVCS)

Wiring Diagram — IVCS — (Cont'd)

EL-IVCS-04

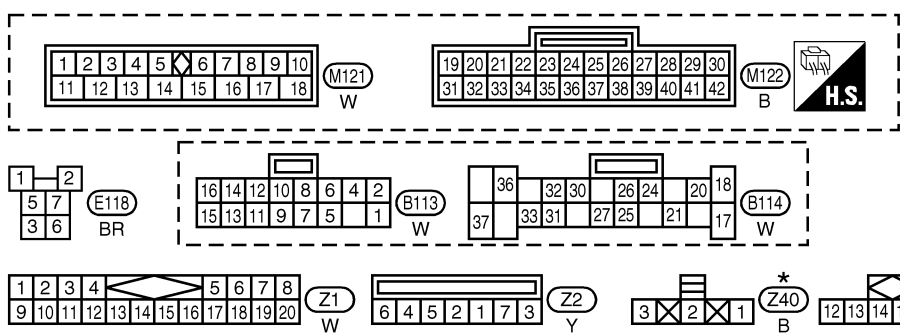
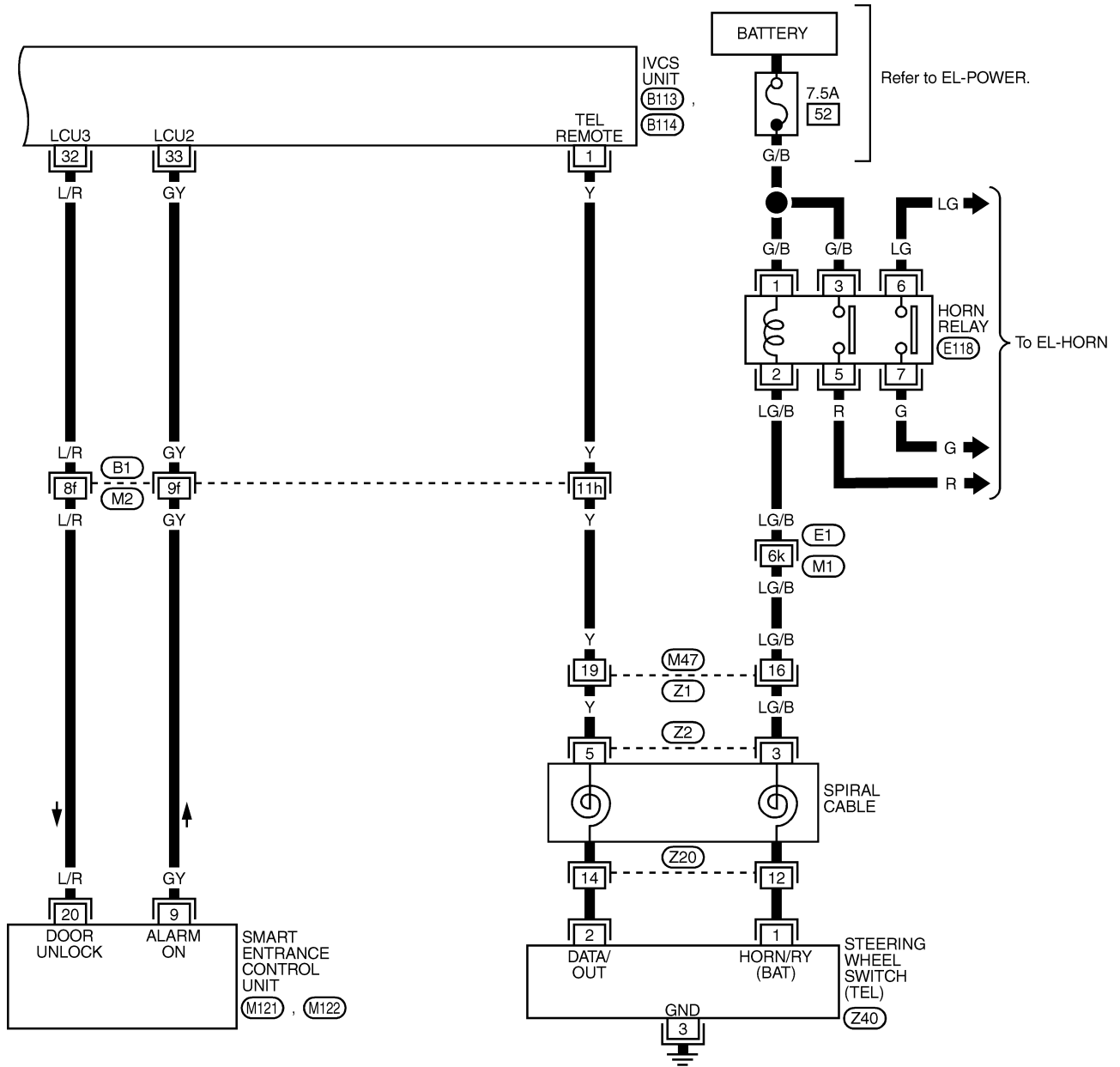

REFER TO THE FOLLOWING.
 (E1), (B1) - SUPER MULTIPLE JUNCTION (SMJ)

* : This connector is not shown in "HARNESS LAYOUT", EL section.

MEL871L

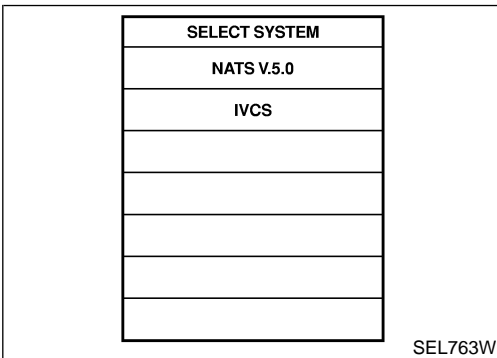
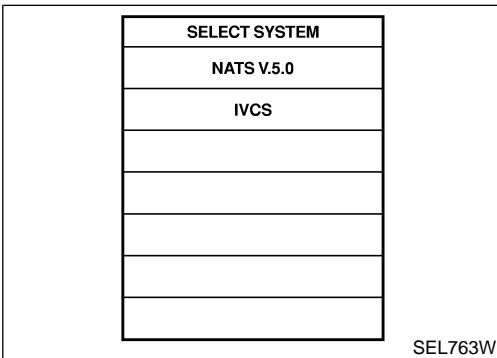
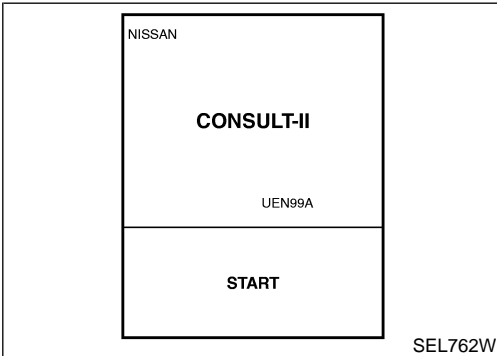
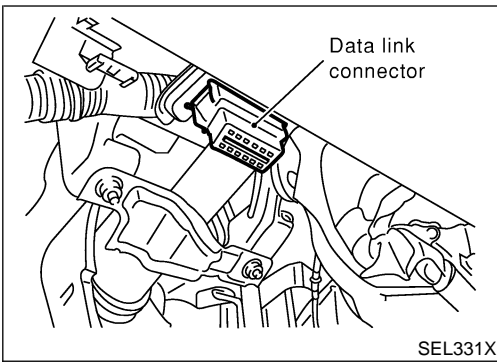

CONSULT-II

CONSULT-II INSPECTION PROCEDURE

NBEL0183

NBEL0183S01

1. Turn ignition switch "OFF".
2. Insert UEN99A program card in to CONSULT-II.
3. Connect CONSULT-II to the data link connector.

GI

MA

EM

LC

4. Turn ignition switch "ON".
5. Touch "START".

EC

FE

AT

TF

6. Touch "IVCS".

PD

AX

SU

BR

7. Perform each diagnostic item according to the item application chart as follows:

ST

RS

BT

HA

8. When CONSULT-II inspection is terminated, follow the procedure shown below.

SC

- a. Touch "BACK" key of CONSULT-II until "SELECT SYSTEM" appears, then turn off CONSULT-II.
- b. Turn ignition switch to OFF position.
- c. Disconnect CONSULT-II DDL connector.

EL

IDX

NOTE:

If the DDL connector is disconnected before turning ignition switch to "OFF" position, INFINITI communicator may not operate properly.

INFINITI COMMUNICATOR (IVCS)

CONSULT-II (Cont'd)

APPLICATION ITEMS

NBEL0183S02

Mode	Description	Reference page
SELF DIAG RESULTS	Displays the result of self-diagnosis.	EL-364
DATA MONITOR	Two modes, "GPS MONITOR" and "SWITCH MONITOR" can be selected in this mode. <ul style="list-style-type: none"> ● Displays current data related to GPS in "GPS MONITOR" mode. ● Displays IVCS switch and outside door handle switch condition in "SWITCH MONITOR" mode. 	EL-366
FUNCTION CHECK	In this mode, "Remote door unlock function" can be checked using CONSULT-II. Door can be unlocked according to the commands to the smart entrance control unit by the IVCS unit. This check verifies communication circuit between smart entrance control unit and IVCS unit.	EL-374
REGISTERED DATA	Displays the following data registered in the IVCS unit. In this mode the data cannot be re-written. <ul style="list-style-type: none"> ● Unit ID ● Cellular phone number ● VIN (Vehicle Identification Number) 	EL-367
CONFIGURATION (See Note.)	In this mode, the system can be set up in the demonstration mode to confirm system operation.	EL-379
	Various data related to both the Communicator Response Center contract and cellular provider can be written/updated in this mode. <ul style="list-style-type: none"> ● Phone number ● NAM (Number Assignment Module) ● Stolen vehicle tracking setting (Default should always be on.) ● Alarm notification setting (Default should always be on.) 	EL-381
ECU PART NUMBER	Displays the part number of the IVCS unit.	—

NOTE:

Data must not be rewritten without prior approval from the customer.

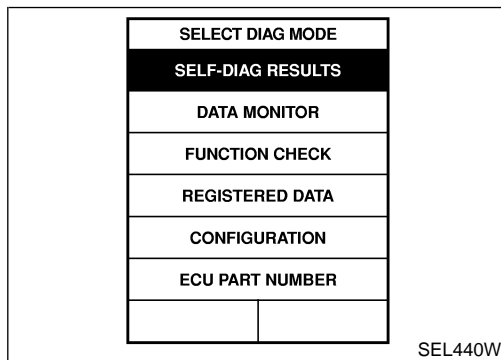

“SELF-DIAG RESULTS” MODE
How to Perform Self-diagnosis

NBEL0183S03

NBEL0183S0301

1. Touch “SELF-DIAG RESULTS”.
2. Touch “START”.

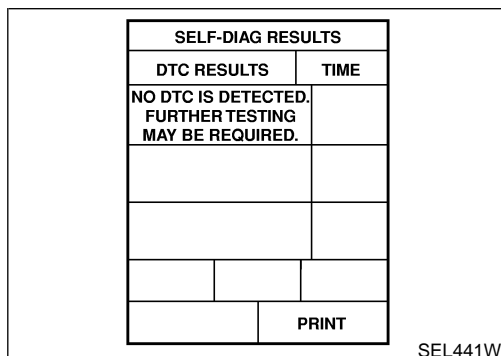

3. If no malfunction is detected, CONSULT-II will show “NO DTC”.

INFINITI COMMUNICATOR (IVCS)

CONSULT-II (Cont'd)

SELF-DIAG RESULTS	
DTC RESULTS	TIME
CONNECTION ERROR [GPS ANTENNA]	0
CONNECTION ERROR [AIR BAG]	0
	PRINT

SEL442W

SELF-DIAG RESULTS	
DTC RESULTS	TIME
CONNECTION ERROR [GPS ANTENNA]	1
CONNECTION ERROR [AIR BAG]	1
	PRINT

SEL443W

- If trouble codes are displayed with “TIME = 0”, repair/replace the system according to “SYMPTOM CHART 1 (SELF-DIAGNOSIS ITEM)”, EL-369.
- In this case, both “MAYDAY” and “INFORMATION” indicator lamps illuminate for more than 30 seconds while the ignition switch is in the ON position.

NOTE:

The time data in CONSULT-II “SELF-DIAG RESULTS” mode displays the number of ignition switch cycles without the same malfunctioning occurring.

- If trouble codes are displayed with “TIME = 1 or greater”, it means that the trouble code is historical data. So no further diagnosis is required.

NOTE:

If trouble codes are displayed with “TIME = 1 or greater” even though the INFINITI Communicator has never been serviced. Intermittent incidents may occur. Check the system, refer to “Trouble Diagnoses for Intermittent Incident”, EL-377.

- If the system does not detect any trouble, the IVCS indicators will turn off after bulb check (self-diagnosis) is completed while the ignition switch is in the ON position.

NOTE:

- The trouble codes cannot be erased by CONSULT-II.
- After 50 ignition cycles, the trouble codes are no longer displayed in the CONSULT-II “SELF-DIAG RESULTS” mode.
- The IVCS unit does not count the ignition switch cycles unless the ignition switch is OFF for more than 3 minutes between each ignition switch cycle.

GI
MA
EM
LC
EC
FE
AT
TF
PD
AX
SU
BR
ST
RS
BT
HA
SC
EL
IDX

INFINITI COMMUNICATOR (IVCS)

CONSULT-II (Cont'd)

“DATA MONITOR” MODE How to Perform Data Monitor

NBEL0183S04

NBEL0183S0401

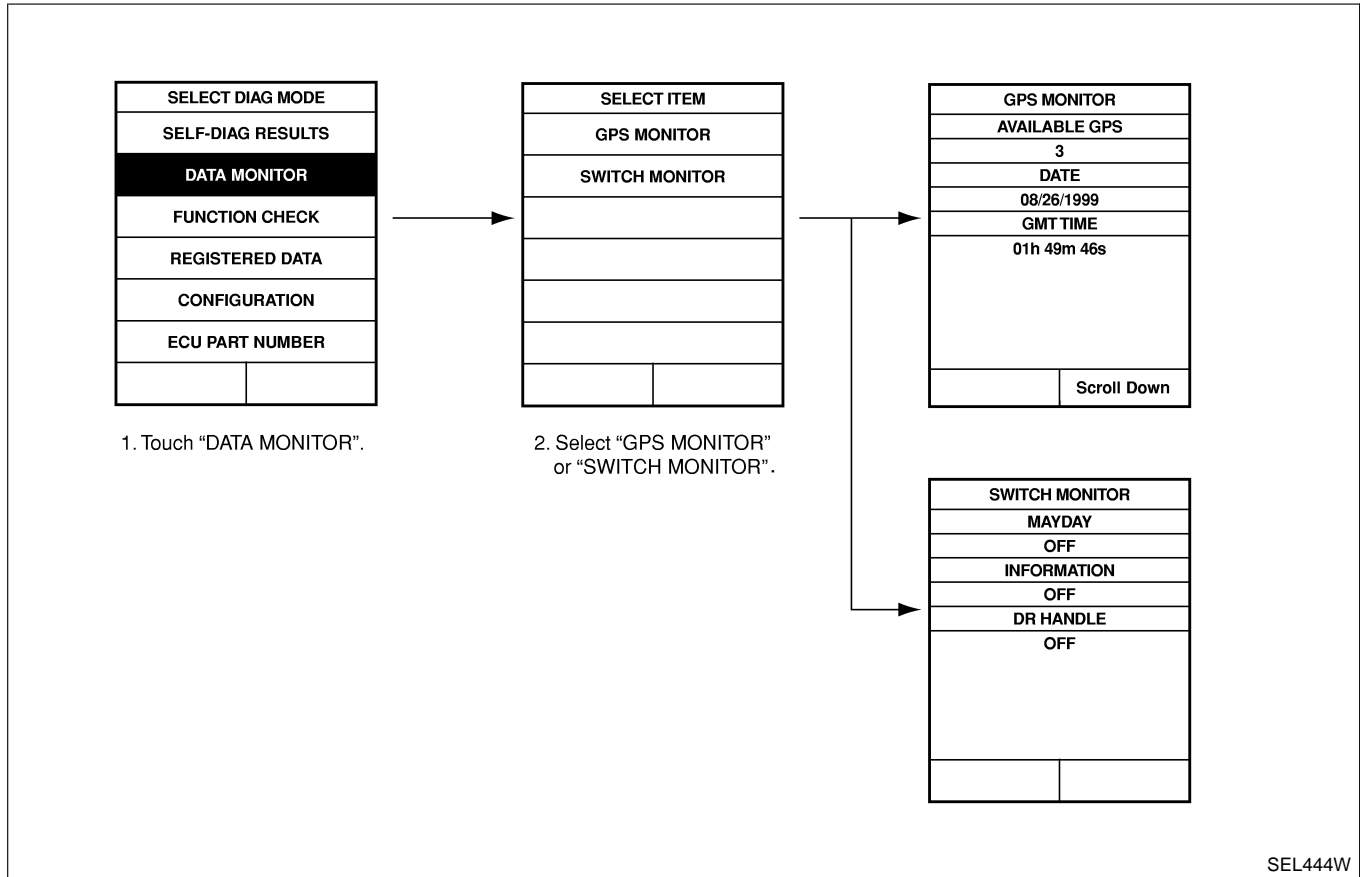

SEL444W

Data Monitor Item Chart

NBEL0183S0402

Mode	Monitor item	Description
GPS MONITOR	AVAILABLE GPS	The number of GPS satellites captured by GPS antenna
	DATE	Date of Greenwich mean time
	GMT TIME	Greenwich mean time (Different from local time)
	LAT.	Latitude
	LONG.	Longitude
	DOP	Index of precision (an index of location status of GPS satellites. The smaller the value is, the higher the positioning precision is.)
SWITCH MONITOR	MAYDAY	"MAYDAY" emergency switch condition
	INFORMATION	"INFORMATION" switch condition
	DR HANDLE	Back door handle switch condition

INFINITI COMMUNICATOR (IVCS)

CONSULT-II (Cont'd)

REGISTERED DATA	
UNIT ID	
SSNSXXXXXX	
CELLULAR PHONE#	
XXX-XXX-XXXX	
VIN#	
XXXXXXXXXXXXXXXXXX	
PRINT	

SEL445W

“REGISTERED DATA” MODE

NBEL0183S05

Item	Description
UNIT ID	ID number of the IVCS unit. ID number is unique to each unit and differs for each unit.
CELLULAR PHONE #	—
VIN #	Vehicle Identification Number. When the IVCS unit is replaced, VIN # is written in the memory of the replaced unit by transmitting data from the Communicator Response Center.

NOTE:
No data can be changed in this CONSULT-II mode.

GI

MA

EM

LC

EC

FE

AT

TF

PD

AX

SU

BR

ST

RS

BT

HA

SC

EL

IDX

INFINITI COMMUNICATOR (IVCS)

Trouble Diagnoses WORK FLOW

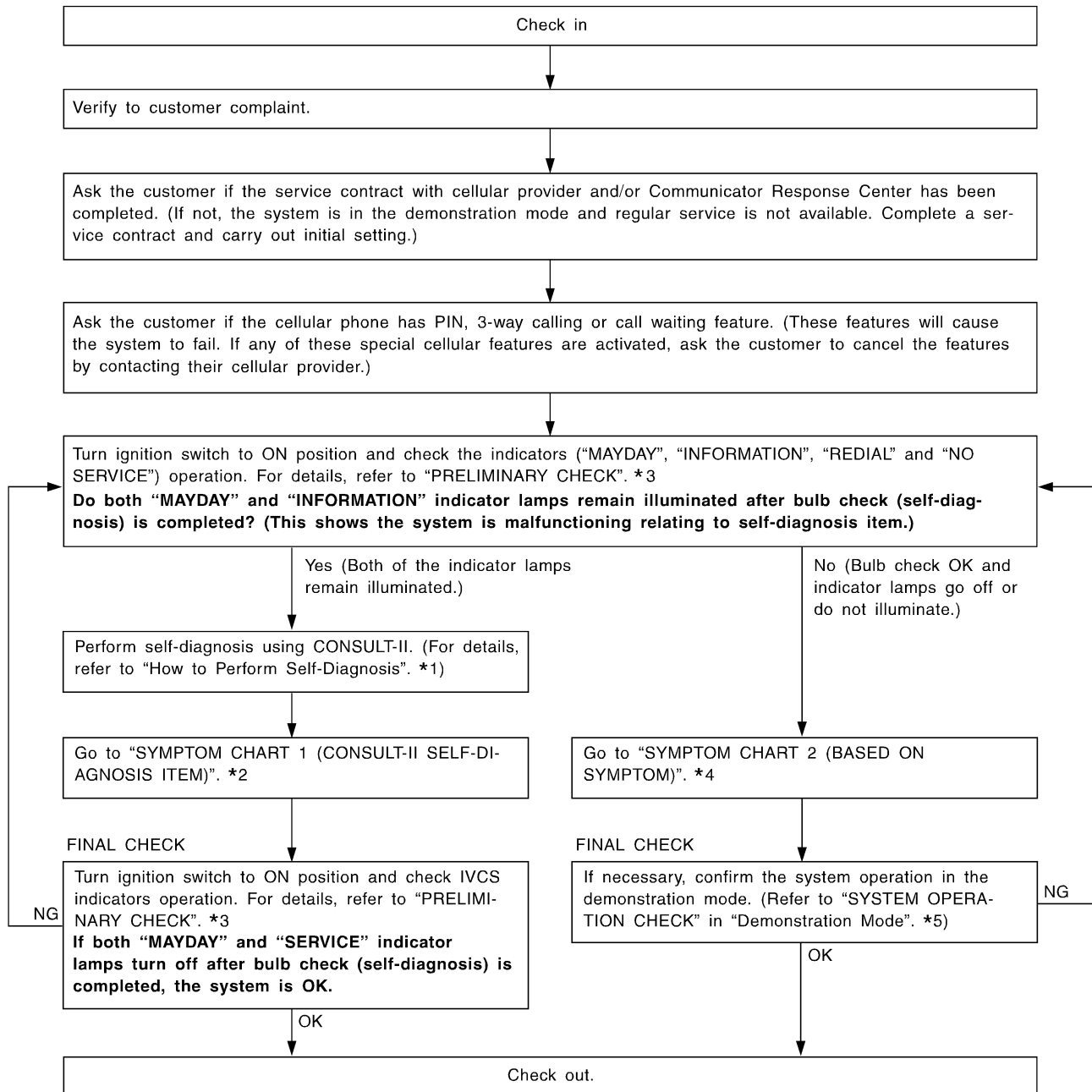

*1: EL-364

*3: EL-369

*5: EL-379

*2: EL-369

*4: EL-370

WARNING:

- Whenever possible, set the system to "Demonstration mode" if INFINITI Communicator system needs to be activated during service procedures. (For details of the demonstration mode, refer to EL-379.)
- If you activate the INFINITI Communicator system (when the system is not in the demonstration mode), the Communicator Response Center operator may dispatch police.

NBEL0184S02

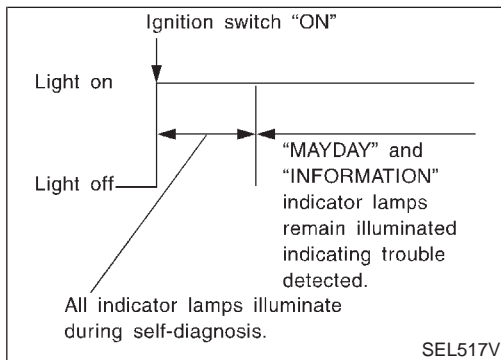
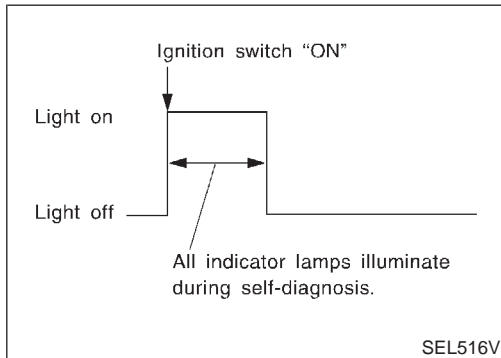
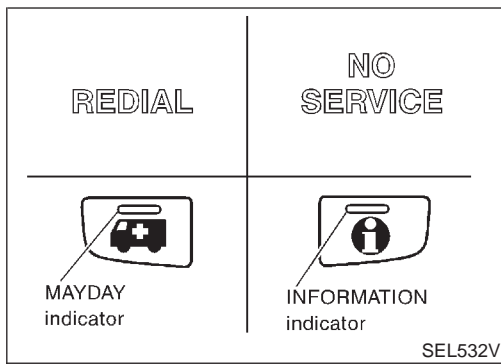

PRELIMINARY CHECK

1. Turn ignition switch ON.
2. Check "MAYDAY", "INFORMATION", "REDIAL" and "NO SERVICE" indicator lamps operation.

- If no malfunction is detected, indicator lamps will turn off after the bulb check (self-diagnosis) is terminated for about 30 seconds or more.

NOTE:

- Bulb check (self-diagnosis) is not performed unless the ignition switch has been turned off for at least 3 minutes.
- Bulb check is not performed during contact with Communicator Response Center.

- If the system detects malfunctions, both "MAYDAY" and "INFORMATION" indicator lamps remain illuminated. Perform self-diagnosis using CONSULT-II and repair or replace the system. Refer to "How to Perform Self-diagnosis", EL-364.

NOTE:

For details of indicator lamps operation, refer to "INDICATOR LAMPS OPERATION", EL-354.

SYMPTOM CHART 1 (CONSULT-II SELF-DIAGNOSIS ITEM)

NBEL0184S03

Detected items (Screen items)	Description	Service procedure
CONNECTION ERROR [GPS ANTENNA]	Connection error between GPS antenna and IVCS unit.	Go to GPS ANTENNA CHECK, EL-376.
CELLULAR PHONE [TWB ERROR]	Communication error between CPU in the IVCS unit and transceiver	Replace IVCS unit.
MEMORY ERROR	Inner memory error of the IVCS unit	Replace IVCS unit.
CONNECTION ERROR [AIR BAG]	Connection error between air bag diagnosis sensor unit and IVCS unit.	Go to AIR BAG DIAGNOSIS SENSOR COMMUNICATION CHECK, EL-376.
CONNECTION ERROR [IVMS or S/ENT]	Connection error between smart entrance control unit and IVCS unit. If this error occurs, alarm notification and auto door unlock may not operate.	Go to SMART ENTRANCE CONTROL UNIT COMMUNICATION CHECK, EL-376.

INFINITI COMMUNICATOR (IVCS)

Trouble Diagnoses (Cont'd)

NOTE:

After replacing IVCS unit, set up the replaced IVCS unit. Refer to "System Setting (When IVCS Unit is Replaced.)" in EL-381.

SYMPTOM CHART 2 (BASED ON SYMPTOM)

NBEL0184S04

Before referencing this chart, confirm the operation of the indicator lamps. Refer to "PRELIMINARY CHECK" in EL-369. If the indicators show the system is malfunctioning, perform the self-diagnosis using CONSULT-II.

Symptom	Diagnoses/service procedure	Reference page
"MAYDAY", "INFORMATION", "RE-DIAL", "NO SERVICE" indicator lamps do not illuminate when ignition switch is turned to ON position. (Bulb check is NG.)	1. Power supply and ground circuit for IVCS unit check	EL-371
	2. Indicator lamps check	EL-372
Mayday/Information call does not operate.	1. IVCS switch check	EL-373
	2. INFINITI Communicator operation check in demonstration mode	EL-379
Remote door unlocking function does not operate.	1. Back door handle switch check	EL-374
	2. Remote door unlock function check	EL-374
	3. INFINITI Communicator operation check in demonstration mode	EL-379
Stolen vehicle tracking function does not operate.	1. Stolen vehicle tracking setting check (Check whether the function is disabled or not.)	EL-375
	2. INFINITI Communicator operation check in demonstration mode	EL-379
Alarm notification function does not operate.	1. Alarm notification setting check (Check whether the function is disabled or not.)	EL-375
	2. INFINITI Communicator operation check in demonstration mode	EL-379
Hands free telephone cannot be operated by using steering switch. (Cellular phone operates properly by using handset.)	1. Telephone steering switch check	EL-377
No sounds related to the telephone are heard from Front RH speaker. (If the audio does not operate properly, check the audio system.)	1. Check harness for open or short between IVCS unit and audio unit.	—
The "NO SERVICE" indicator lamp is not turned off. (Even if a contract with telephone carrier has not been made, the indicator lamp remains illuminated.)	1. Make sure the vehicle is in an area with cellular service.	—
	2. Check cellular phone antenna feeder cable connection.	—
Cellular phone does not operate properly.	1. Check hand set connector connection.	—
	2. Check hand set.	—
No sound is transmitted to the other party by hands free telephone.	1. Check harness for open or short between IVCS unit and microphone.	—
	2. Replace microphone. (IVCS switch assembly)	—

INFINITI COMMUNICATOR (IVCS)

Trouble Diagnoses (Cont'd)

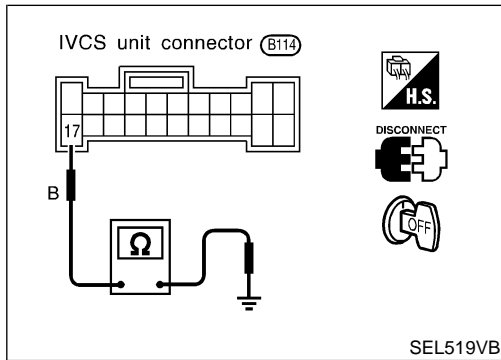
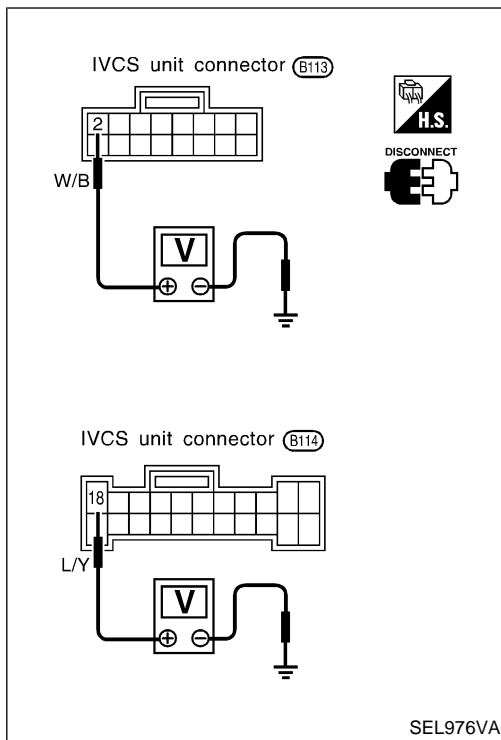

POWER SUPPLY AND GROUND CIRCUIT FOR IVCS UNIT CHECK

NBEL0184S05

Main Power Supply Circuit Check

NBEL0184S0501

Terminal		Ignition switch		
(+)	(-)	OFF	ACC	ON
18	Ground	Battery voltage	Battery voltage	Battery voltage
2	Ground	0V	0V	Battery voltage

If NG, check the following:

- 15A fuse [No. 4, located in fuse and fusible link box]
- 7.5A fuse [No. 11, located in fuse block (J/B)]
- Harness for open or short between fuse and IVCS unit

Ground Circuit Check

NBEL0184S0502

Terminals	Continuity
17 - Ground	Yes

GI
MA
EM
LC
EC
FE
AT
TF
PD
AX
SU
BR
ST
RS
BT
HA
SC
EL
IDX

INFINITI COMMUNICATOR (IVCS)

Trouble Diagnoses (Cont'd)

INDICATOR LAMPS CHECK

=NBEL0184S06

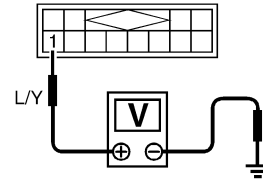
1	CHECK POWER SUPPLY FOR INDICATOR LAMPS	<p>Check voltage between IVCS switch terminal 1 and ground.</p> <div style="display: flex; justify-content: space-around; align-items: center;"> <div style="text-align: center;">  <p>IVCS switch connector (R10)</p>  </div> <div style="text-align: center;"> <p>Battery voltage should exist.</p> </div> </div> <p style="text-align: right;">SEL372X</p> <p style="text-align: center;">OK or NG</p>
OK	▶	GO TO 2.
NG	▶	<p>Check the following.</p> <ul style="list-style-type: none"> ● 15A fuse [No. 4, located in fuse block (J/B)] ● Harness for open or short between fuse and IVCS switch

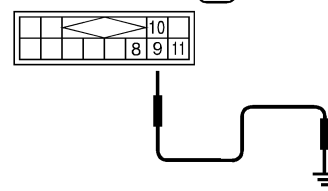
2	CHECK INDICATOR LAMPS	<p>1. Disconnect IVCS unit connector (Control unit connector). 2. Apply ground to IVCS switch each terminal and check illumination.</p> <div style="display: flex; justify-content: space-around; align-items: center;"> <div style="text-align: center;">  <p>IVCS switch connector (R10)</p>  </div> <div style="border: 1px solid black; padding: 5px;"> <table style="width: 100%; border-collapse: collapse;"> <thead> <tr> <th style="width: 50%;">Indicator</th> <th style="width: 50%;">Terminal</th> </tr> </thead> <tbody> <tr> <td>REDIAL</td> <td style="text-align: center;">8</td> </tr> <tr> <td>NO SERVICE</td> <td style="text-align: center;">9</td> </tr> <tr> <td>MAYDAY</td> <td style="text-align: center;">10</td> </tr> <tr> <td>INFORMATION</td> <td style="text-align: center;">11</td> </tr> </tbody> </table> </div> </div> <p style="text-align: right;">SEL373X</p> <p style="text-align: center;">OK or NG</p>	Indicator	Terminal	REDIAL	8	NO SERVICE	9	MAYDAY	10	INFORMATION	11
Indicator	Terminal											
REDIAL	8											
NO SERVICE	9											
MAYDAY	10											
INFORMATION	11											
OK	▶	Check harness for open or short between indicators and IVCS unit.										
NG	▶	Replace IVCS switch assembly.										

IVCS SWITCH CHECK

=NBEL0184S07

1	CHECK IVCS SWITCH INPUT SIGNAL	<p>1. Turn ignition switch "ON". 2. Select "SWITCH MONITOR" in "DATA MONITOR" mode. 3. Check each switch signal.</p> <p>Condition: When MAYDAY/INFORMATION switch is pushed: MAYDAY/INFORMATION ON When MAYDAY/INFORMATION switch is released: MAYDAY/INFORMATION OFF</p> <p>NOTE: When CONSULT-II "DATA MONITOR" mode is operating, INFINITI Communicator does not dial to Communicator Response Center when the switches are operated.</p> <p style="text-align: center;">OK or NG</p>	GI MA EM LC EC FE
	OK	▶	IVCS switch is OK.
	NG	▶	GO TO 2.

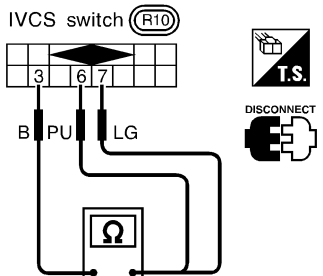
2	CHECK IVCS SWITCH.	<p>1. Disconnect IVCS switch. 2. Check continuity between IVCS switch terminals.</p> <div style="display: flex; align-items: center; justify-content: space-around;"> <div style="text-align: center;">  </div> <table border="1" style="border-collapse: collapse;"> <thead> <tr> <th style="text-align: center;">Terminals</th> <th style="text-align: center;">Condition</th> <th style="text-align: center;">Continuity</th> </tr> </thead> <tbody> <tr> <td rowspan="2" style="text-align: center; vertical-align: middle;">6 - 3</td> <td>Mayday switch is turned ON.</td> <td style="text-align: center;">Yes</td> </tr> <tr> <td>Mayday switch is OFF.</td> <td style="text-align: center;">No</td> </tr> <tr> <td rowspan="2" style="text-align: center; vertical-align: middle;">7 - 3</td> <td>Information switch is turned ON.</td> <td style="text-align: center;">Yes</td> </tr> <tr> <td>Information switch is OFF.</td> <td style="text-align: center;">No</td> </tr> </tbody> </table> </div> <p style="text-align: right;">SEL374X</p> <p style="text-align: center;">OK or NG</p>	Terminals	Condition	Continuity	6 - 3	Mayday switch is turned ON.	Yes	Mayday switch is OFF.	No	7 - 3	Information switch is turned ON.	Yes	Information switch is OFF.	No	AT TF PD AX SU BR ST RS
Terminals	Condition	Continuity														
6 - 3	Mayday switch is turned ON.	Yes														
	Mayday switch is OFF.	No														
7 - 3	Information switch is turned ON.	Yes														
	Information switch is OFF.	No														
	OK	▶	<p>Check the following.</p> <ul style="list-style-type: none"> ● IVCS switch ground circuit ● Harness for open or short between IVCS switch and IVCS unit 													
	NG	▶	Replace IVCS switch assembly.													

GI
 MA
 EM
 LC
 EC
 FE
 AT
 TF
 PD
 AX
 SU
 BR
 ST
 RS
 BT
 HA
 SC
 EL
 IDX



INFINITI COMMUNICATOR (IVCS)

Trouble Diagnoses (Cont'd)

BACK DOOR HANDLE SWITCH CHECK

=NBEL0184S08

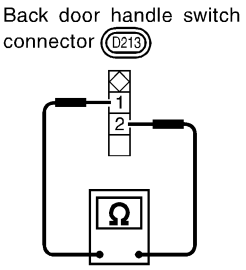
1	CHECK BACK DOOR HANDLE SWITCH INPUT SIGNAL	
<p>1. Turn ignition switch ON. 2. Select "SWITCH MONITOR" in "DATA MONITOR" mode. 3. Check the switch operation.</p> <p>Condition: When back door handle switch is pushed: DR HANDLE ON When back door handle switch is released: DR HANDLE OFF</p> <p>NOTE: When CONSULT-II "DATA MONITOR" mode is operating, INFINITI Communicator does not dial to Communicator Response Center when the switches are operated.</p> <p style="text-align: center;">OK or NG</p>		
OK	▶	Back door handle switch is OK.
NG	▶	GO TO 2.

2	CHECK BACK DOOR HANDLE SWITCH							
<p>1. Disconnect back door handle switch connector. 2. Check continuity between back door handle switch terminals 1 and 2.</p> <div style="display: flex; align-items: center; justify-content: space-around;"> <div style="text-align: center;"> <p>Back door handle switch connector (D213)</p>  </div> <div style="text-align: center;">  </div> <div style="border: 1px solid black; padding: 5px;"> <table border="1"> <thead> <tr> <th>Back door handle switch condition</th> <th>Continuity</th> </tr> </thead> <tbody> <tr> <td>Pulled</td> <td>Yes</td> </tr> <tr> <td>Released</td> <td>No</td> </tr> </tbody> </table> </div> </div> <p style="text-align: right;">SEL375X</p> <p style="text-align: center;">OK or NG</p>			Back door handle switch condition	Continuity	Pulled	Yes	Released	No
Back door handle switch condition	Continuity							
Pulled	Yes							
Released	No							
OK	▶	<p>Check the following.</p> <ul style="list-style-type: none"> ● Back door handle switch ground circuit ● Harness for open or short between back door handle switch and IVCS unit 						
NG	▶	Replace back door handle switch.						

REMOTE DOOR UNLOCK FUNCTION CHECK (CONSULT-II "FUNCTION CHECK" MODE)

NBEL0184S09

Description

NBEL0184S0901

"Remote door unlock function" can be checked using CONSULT-II. Driver side door can be unlocked according to the commands to the smart entrance control unit by the IVCS unit.

NOTE:

Before performing the function check, confirm that power door lock system operates properly.

INFINITI COMMUNICATOR (IVCS)

Trouble Diagnoses (Cont'd)

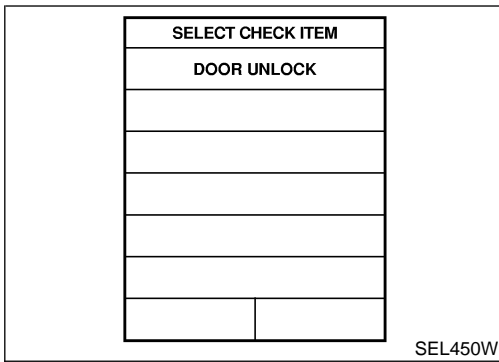

SEL450W

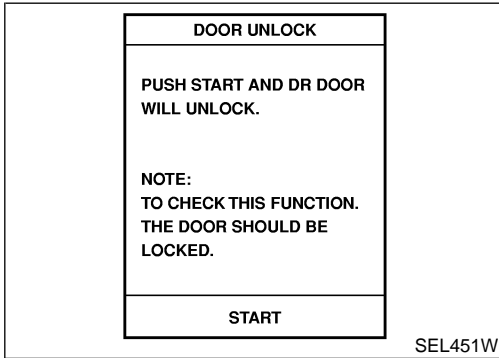

SEL451W

How to perform function check.

1. Lock the doors with door lock/unlock switch on driver's door trim.
2. Touch "FUNCTION CHECK".
3. Touch "DOOR UNLOCK".
4. Touch "START". Then driver side door will be unlocked.
 - If the door cannot be unlocked using CONSULT-II, check harness for open or short between smart entrance control unit terminal 20 and IVCS unit terminal 32.

GI
MA
EM
LC
EC
FE
AT
TF

STOLEN VEHICLE TRACKING/ALARM NOTIFICATION SETTING CHECK (CONSULT-II "CONFIGURATION" MODE)

NBEL0184S10

1	CHECK SYSTEM SETTING
<p>1. Turn ignition switch ON. 2. Select "VHCL TRACKING" or "ALARM NOTIFICATION" in "CONFIGURATION" mode. 3. Check the function setting.</p>	
<p>A screenshot of a touch-screen menu. At the top, it says 'VEHICLE TRACKING'. Below that, it says 'CURRENT SETTING IS ON'. Underneath, it says 'VEHICLE TRACKING FUNCTION IS ACTIVE.' At the bottom, there are two buttons: 'OFF' and 'PRINT'.</p>	
<p>● ON shows the function is activated. ● OFF shows the function is deactivated.</p> <p>Does the system setting comply with the customer's contract? NOTE: Setting of "VEHICLE TRACKING" must be ON at all times.</p> <p style="text-align: center;">OK or NG</p>	
OK	▶ System setting is OK.
NG	▶ If either setting is OFF, contact the Communicator Response Center at 1-888-427-4812 to verify the system setting. NOTE: Whenever dialing the above number, some information about the vehicle will be required by the operator. For details, refer to EL-348.

SEL452W

AX
SU
BR
ST
RS
BT
HA
SC

EL
IDX

INFINITI COMMUNICATOR (IVCS)

Trouble Diagnoses (Cont'd)

GPS ANTENNA CHECK

=NBEL0184S11

1	CHECK VOLTAGE FOR GPS ANTENNA	
<p>1. Disconnect GPS feeder cable connector from IVCS unit. 2. Turn ignition switch ON. 3. Check voltage at IVCS unit GPS feeder cable terminal.</p>		
<p>The diagram illustrates the setup for checking the voltage at the IVCS unit's GPS feeder cable terminal. A voltmeter is connected to the terminal, and the ground is connected to the IVCS unit. Icons above the unit indicate the steps: 'T.S.' (Turn Switch), 'DISCONNECT' (GPS connector), and 'ON' (Ignition switch).</p>		
Does approx. 5V exist?		
Yes	▶	Replace GPS antenna.
No	▶	Replace IVCS unit.

SEL106W

AIR BAG DIAGNOSES SENSOR UNIT COMMUNICATION CHECK

NBEL0184S12

1	AIR BAG OPERATION CHECK	
Turn ignition switch ON and check air bag warning lamp operation. (For details, refer to RS-38.)		
Does air bag warning lamp operate properly?		
Yes	▶	Check harness connector connection between air bag diagnosis sensor unit and IVCS unit.
No	▶	Check supplemental restraint system. Refer to RS-29.

SMART ENTRANCE CONTROL UNIT COMMUNICATION CHECK

NBEL0184S13

1	CHECK SMART ENTRANCE CONTROL UNIT OPERATION	
Check the system related smart entrance control unit operation. (e.g.: power door lock, power window)		
Does the system operate properly?		
Yes	▶	Check harness for open or short between smart entrance control unit and IVCS unit.
No	▶	Check smart entrance control unit. Refer to "SMART ENTRANCE CONTROL UNIT" in the Service Manual. (EL-324)

INFINITI COMMUNICATOR (IVCS)

Trouble Diagnoses (Cont'd)

TELEPHONE STEERING SWITCH CHECK

=NBEL0184S14

1	CHECK POWER SUPPLY FOR STEERING SWITCH	
Check power supply for steering switch.		
Does horn work?		
Yes	▶	Check the following. <ul style="list-style-type: none"> ● 10A fuse (No. 54, located in fuse and fusible link box) ● Horn relay ● Harness for open or short
No	▶	GO TO 2.

GI
MA
EM
LC

2	CHECK STEERING SWITCH SUB-HARNESS	
1. Remove driver's air bag module. For removal procedure, refer to RS section. 2. Check steering switch sub-harness for open or short and ground screw. For details of the harness circuit, refer to "STEERING SWITCH", EL-30.		
OK or NG		
OK	▶	Check harness for open or short between telephone steering switch and IVCS unit. If the circuit is OK, replace telephone steering switch.
NG	▶	Replace or repair the harness.

EC
FE
AT
TF

Trouble Diagnoses for Intermittent Incident

NBEL0185

DESCRIPTION

An intermittent incident may be occurring if all of the following conditions exist.

- Both "MAYDAY" emergency and "INFORMATION" indicators have shown that the system is malfunctioning.
- CONSULT-II self-diagnosis result screen indicates a trouble code with "TIME = 1 or greater".
- The INFINITI Communicator system has not been previously serviced.

To find out the cause of a malfunction, follow the procedures shown below.

NBEL0185S01

PD
AX
SU
BR
ST
RS
BT
HA
SC
EL
IDX

INFINITI COMMUNICATOR (IVCS)

Trouble Diagnoses for Intermittent Incident (Cont'd)

DIAGNOSTIC PROCEDURE

NBEL0185S02

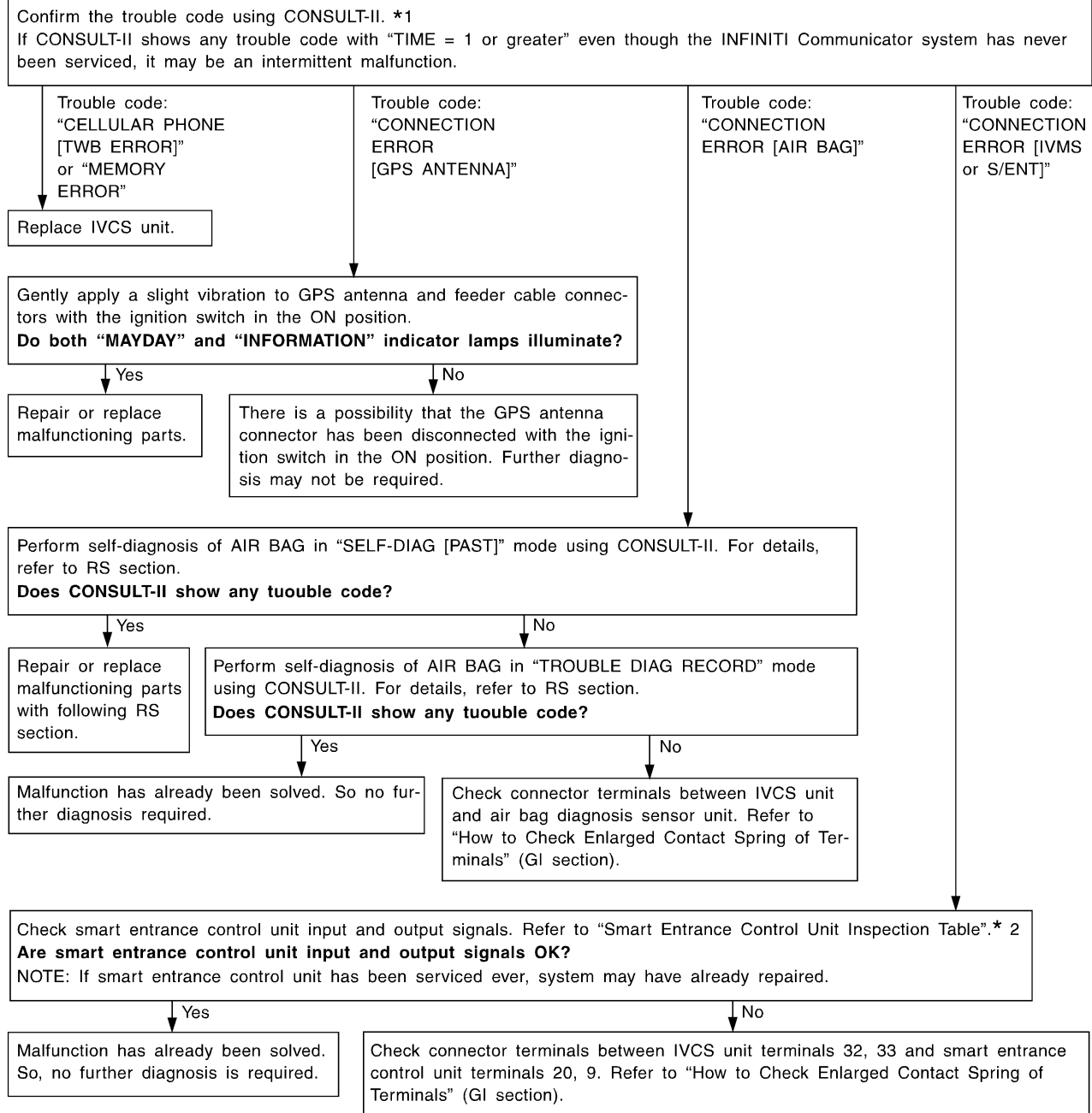

SEL107WF

*1: EL-364

*2: EL-324

NOTE:

Enlarged spring contact of terminals may be cause of intermittent malfunction for "CONNECTION ERROR [AIR BAG]/[IVMS]". When you inspect terminals for enlarged contact, refer to "How to Check Enlarged Contact Spring of Terminals" in GI section.

INFINITI COMMUNICATOR (IVCS)

Demonstration Mode (Cont'd)

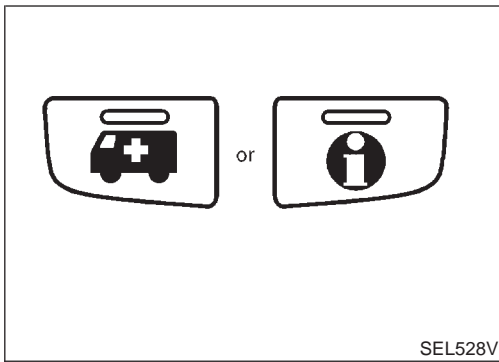

4. Touch “BACK” key of CONSULT-II until “SELECT SYSTEM” appears, then turn off CONSULT-II.
5. Turn ignition switch to the OFF position.
6. Disconnect CONSULT-II DDL connector.
7. Start the engine.
8. Touch the “MAYDAY” or “INFORMATION” switches. Then the system will call the demonstration center.

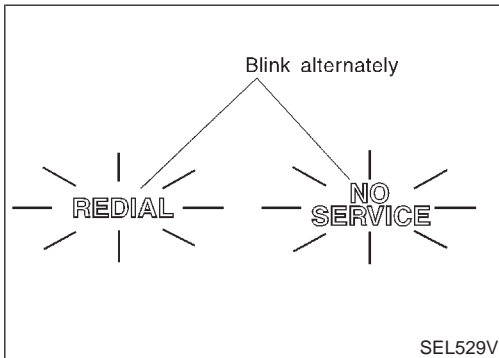

9. Check INFINITI Communicator operation.
 - If contact with Communicator Response Center is successful, system is OK.

NOTE:

During the system contact to Communicator Response Center in demonstration mode, “REDIAL” and “NO SERVICE” indicators blink alternately.

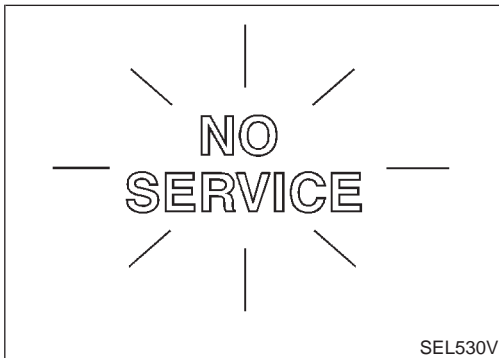

- If “NO SERVICE” indicator illuminates and the contact to Communicator Response Center is unsuccessful, retry from other location where the cellular connection seems good. (e.g.; move the vehicle outside of the workshop and retry.)

NOTE:

If “NO SERVICE” indicator frequently illuminates from a location where the cellular connection seems good, check the connection of the feeder cable for the cellular phone antenna.

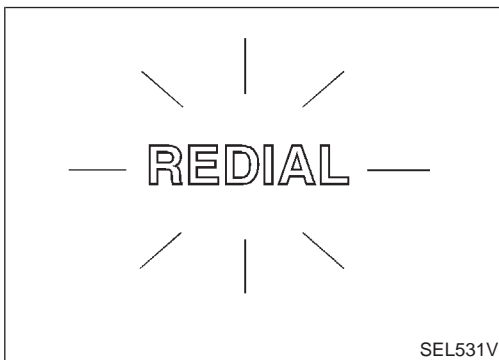

- If “REDIAL” indicator lamp illuminates and the contact to Communicator Response Center is unsuccessful, the cellular network is busy or there are no open cellular channels. The system will redial automatically.

NOTE:

If redial fails several times, confirm whether the roaming agreement of customer’s cellular provider at the vehicle location is available or not.

WARNING:

- Make sure to turn the demonstration mode OFF before returning the vehicle to the owner.
- In the demonstration mode, any service from Communicator Response Center is not available. Therefore, even if the customer encounters an emergency, no service will be dispatched.

INFINITI COMMUNICATOR (IVCS)

System Setting (When IVCS Unit is Replaced)

System Setting (When IVCS Unit is Replaced)

NBEL0187

DESCRIPTION

NBEL0187S01

When the IVCS unit is replaced, carry out the following data settings.

- Phone setup — Data setting regarding NAM (Number Assignment Module)
- Phone number — Phone number setting

NOTE:

- **Data must not be updated without prior approval from the customer.**
- **NAM and phone number can be programmed by using handset. For details, refer to the handset operation manual.**
- **The IVCS unit does not permit updating of NAM more than 15 times.**

WORK FLOW

NBEL0187S02

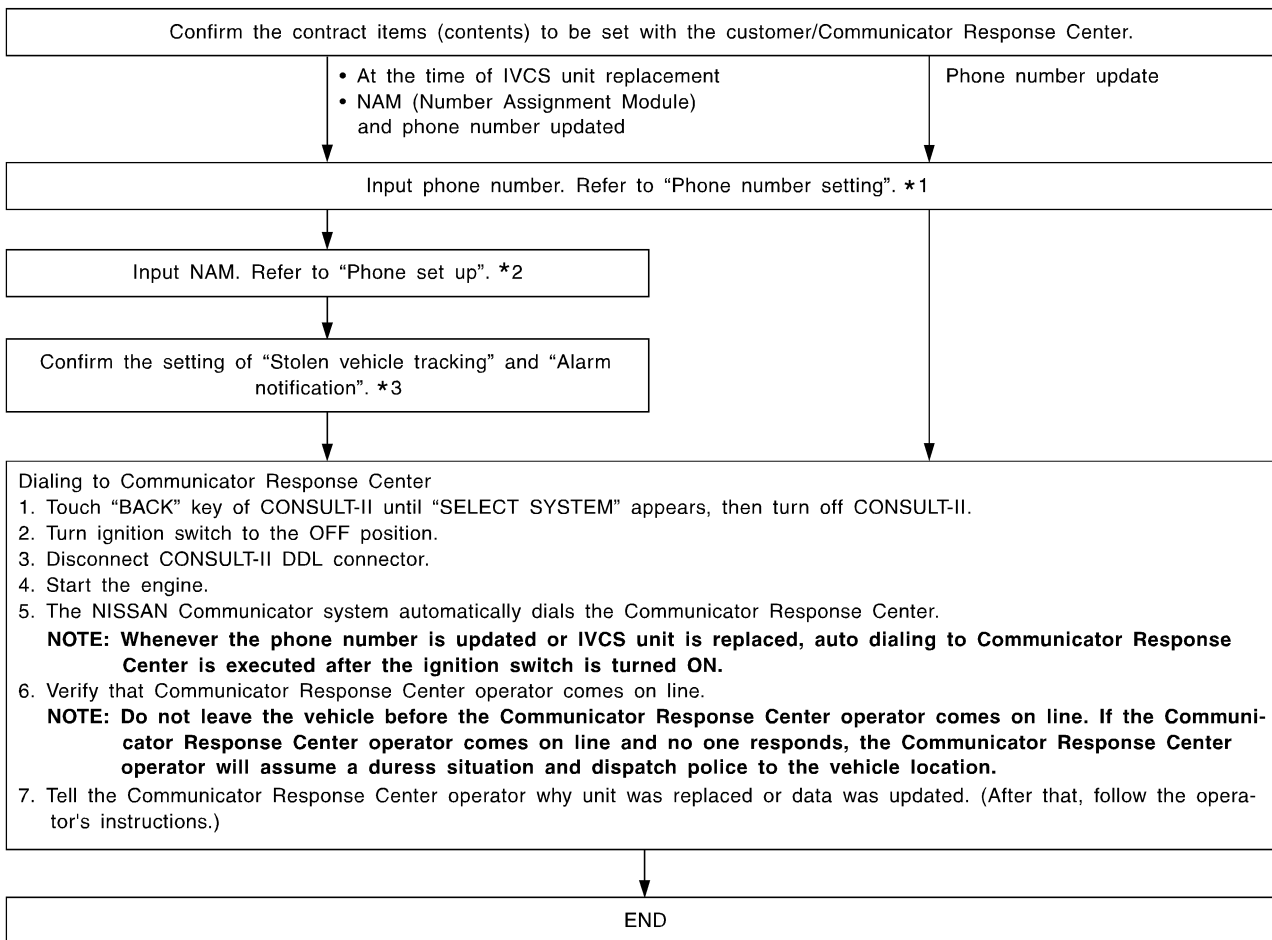

SEL108WC

*1: EL-382

*2: EL-383

*3: EL-384

NOTE:

- **If a Communicator Response Center operator does not come on line even though the system activates, the system may not be properly configured. Call the Communicator Response Center at 1-888-427-4812 to verify the configuration information.**

GI

MA

EM

LC

EC

FE

AT

TF

PD

AX

SU

BR

ST

RS

BT

HA

SC

EL

IDX

INFINITI COMMUNICATOR (IVCS)

System Setting (When IVCS Unit is Replaced) (Cont'd)

PHONE NUMBER	
NEW PHONE#	
XXX - XXX - XXXX	
THE ABOVE CELLULAR PHONE NUMBER WILL BE PROGRAMMED. OK?	
CANCEL	OK

SEL460W

6. Touch "OK".
7. Carry out the next system setting or contact Communicator Response Center and inform them that data has been updated or the IVCS unit has been replaced. For details, refer to EL-381.

NOTE:

Whenever the phone number is updated or the IVCS unit is replaced, the INFINITI Communicator system automatically contacts the Communicator Response Center the first time the vehicle is started.

SELECT ITEM	
PHONE SETUP	
PHONE NUMBER	
VEHICLE TRACKING	
ALARM NOTIFICATION	
DEMO MODE	

SEL461W

PHONE SET UP

NBEL0187S04

1. Touch "CONFIGURATION".
2. Touch "PHONE SET UP".

PHONE SETUP		
THIS UNIT HAS NO REQUIRED DATA PROGRAMMED.		
ERASE	REWRITE	PRINT
Scroll Down		

SEL716W

3. Touch "WRITE" or "REWRITE".
 - If no data is previously memorized, the display shows "This unit has no required data programmed".

PHONE SETUP		
SYS.ID:		
11111		
GR.ID:		
11		
OVERLOAD CLASS:		
11		
THIS UNIT HAS THE ABOVE DATA PROGRAMMED.		
ERASE	REWRITE	PRINT
Scroll Down		

SEL463W

- If NAM (Number Assignment Module) data is previously memorized, the display shows the current NAM data.
- To erase the NAM, touch "ERASE".

PHONE SETUP					
SYS.ID:					
GR.ID:					
OVERLOAD CLASS:					
1	2	3	4	5	6
7	8	9	0	BS	
CANCEL				ENTER	
Scroll Down					

SEL464W

4. Input new NAM data.
 - SYS ID (Carrier system ID number) — Available number: 0 to 32765
 - GR ID (Group ID mark) — Available number: 0 to 15
 - OVERLOAD CLASS (Access overload class) — Available number: 0 to 15
 - SECURITY CODE (User security code)
 - UNLOCK CODE
 - INIT PAGE CH (Initial paging channel)

GI
MA
EM
LC
EC
FE
AT
TF
PD
AX
SU
BR
ST
RS
BT
HA
SC
EL
IDX

INFINITI COMMUNICATOR (IVCS)

System Setting (When IVCS Unit is Replaced) (Cont'd)

NOTE:

If an unavailable number is input as "SYS ID", "GR ID" or "OVERLOAD CLASS", CONSULT-II may be locked. In such cases, disconnect the vehicle battery cable once and then setup the system again.

5. Touch "ENTER".

PHONE SETUP	
SYS.ID:	
11111	
GR.ID:	
11	
OVERLOAD CLASS:	
11	
THE ABOVE DATA WILL BE PROGRAMMED. OK?	
CANCEL	OK
Scroll Down	

SEL465W

6. Touch "OK".

7. Carry out the next system setting or contact Communicator Response Center and inform them that data has been updated or IVCS unit has been replaced. For details, refer to EL-381.

NOTE:

Whenever the phone number is updated or the IVCS unit is replaced, the INFINITI Communicator system automatically contacts the Communicator Response Center the first time the vehicle is started.

SELECT ITEM
PHONE SETUP
PHONE NUMBER
VEHICLE TRACKING
ALARM NOTIFICATION
DEMO MODE

SEL466W

STOLEN VEHICLE TRACKING/ALARM NOTIFICATION SETTING CHECK

NBEL0187S05

1. Touch "CONFIGURATION".

2. Touch "VEHICLE TRACKING" or "ALARM NOTIFICATION".

ALARM NOTIFICATION	
CURRENT SETTING IS	
ON	
ALARM NOTIFICATION FUNCTION IS ACTIVE.	
OFF	PRINT

SEL467W

3. This function should always be "ON" (function activate.)

NOTE:

- If either setting is "OFF", contact the Communicator Response Center at 1-888-427-4812 to verify the system setting.

- Whenever dialing the above number, information about the vehicle is required by the operator. For details, refer to EL-348.

Component Parts Location

NBEL0227

GI

MA

EM

LC

EC

FE

AT

TF

PD

AX

SU

BR

ST

RS

BT

HA

SC

EL

IDX

SEL508X

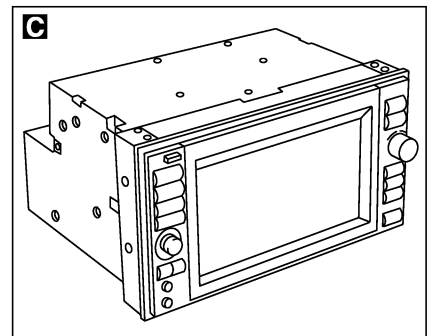
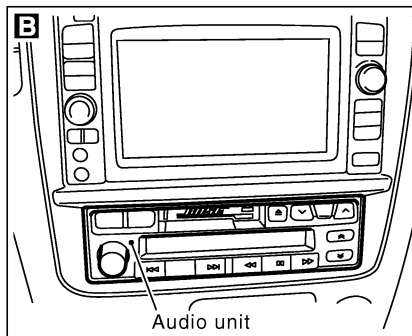
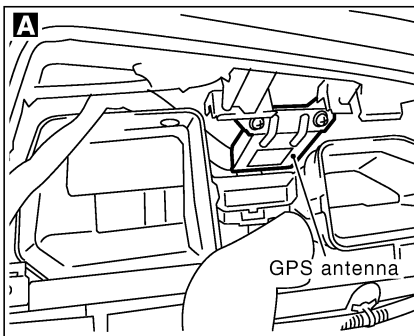
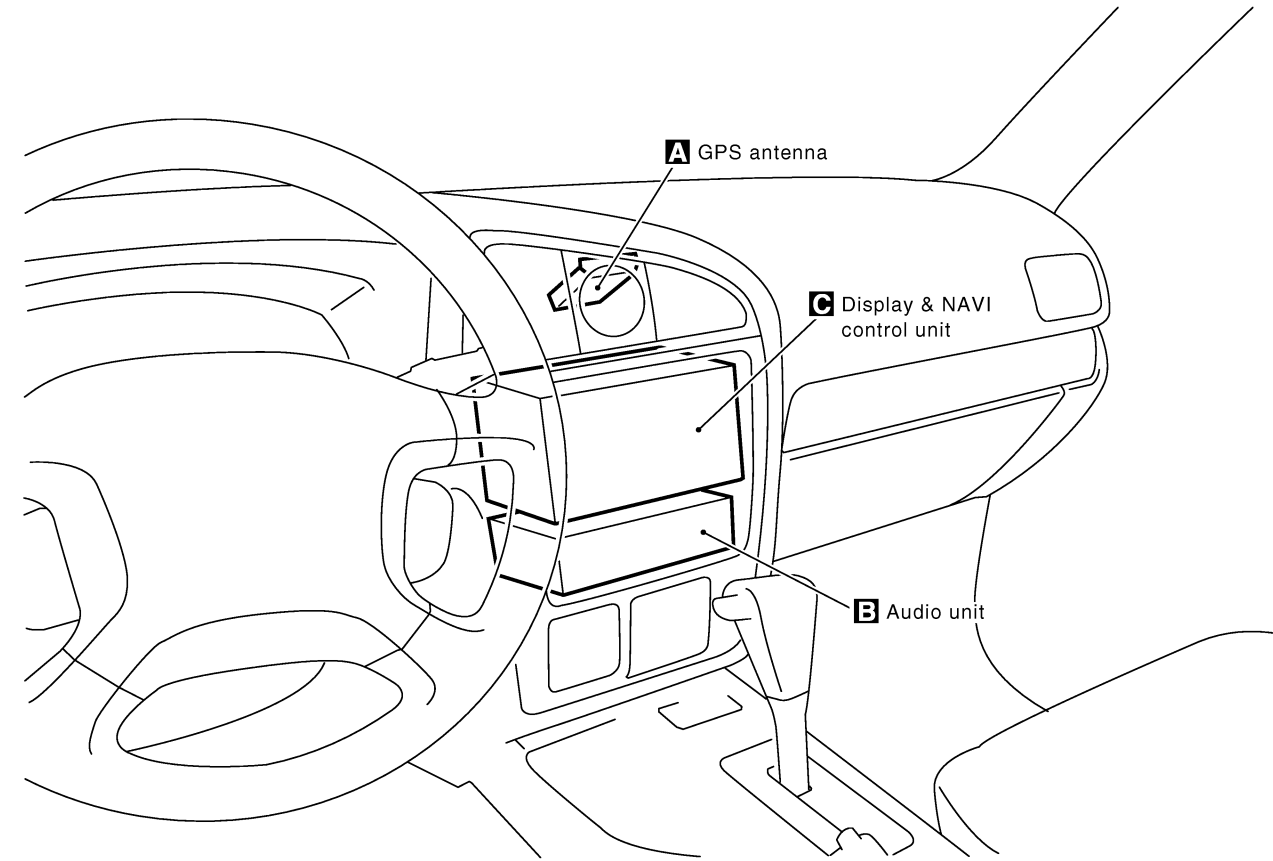

NAVIGATION SYSTEM

System Description

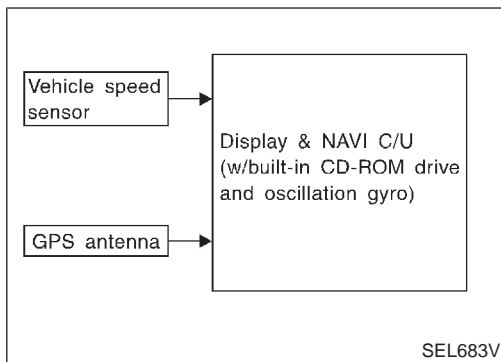

System Description

=NBEL0228

OUTLINE

NBEL0228S01

The Navigation System (Multi-AV System) relies upon three sensing devices in order to determine vehicle location at regular time intervals.

1. Vehicle speed sensor: Determines the distance the vehicle has traveled.
2. Gyro (Angular velocity sensor): Determines vehicle steering angle and directional change.
3. GPS antenna (GPS data): Determines vehicle forward movement and direction.

The data provided by the three sensing functions together with a comparison of the mapping information read from the CD-ROM drive permit accurate determination of the vehicle's current location and subsequent course (map matching). The information appears on a liquid crystal display.

This comparison of GPS data (vehicle position sensing) and map matching permits precise determination of vehicle location.

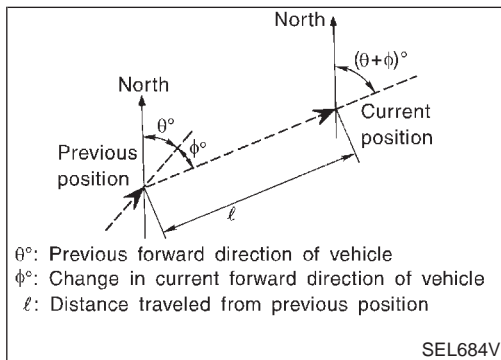

Position Sensor Operating Principles

NBEL0228S0101

The sensor determines current vehicle location by calculating the previously sensed position, the distance traveled from this position, and the directional changes occurring during this travel.

1. Distance traveled
The distance traveled is calculated using signals received from the vehicle speed sensor. The sensor automatically compensates for the slightly reduced wheel and tire diameter resulting from tire wear.
2. Forward movement (Direction)
Changes in the direction of forward movement are calculated by the gyro (angular velocity sensor) and the GPS antenna (GPS data). Each of these functions has its advantage and disadvantages. Depending upon conditions, one function takes precedence over the other to accurately determine the direction of forward movement.

Function type	Advantage	Disadvantage
Gyro (Angular velocity sensor)	<ul style="list-style-type: none"> • Able to accurately detect minute changes in steering angle and direction. 	<ul style="list-style-type: none"> • Calculation errors may accumulate over a long period of continuous vehicle travel.
GPS antenna (GPS data)	<ul style="list-style-type: none"> • Able to sense vehicle travel in four general directions (North, South, East, and West) 	<ul style="list-style-type: none"> • Unable to detect direction of vehicle travel at low vehicle speeds.

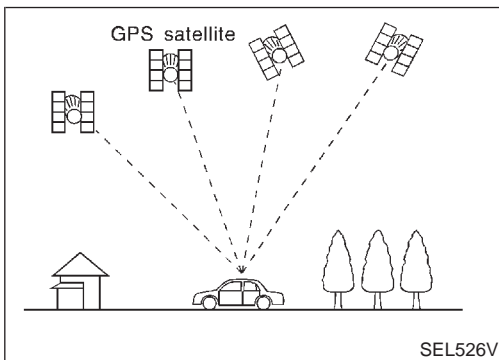
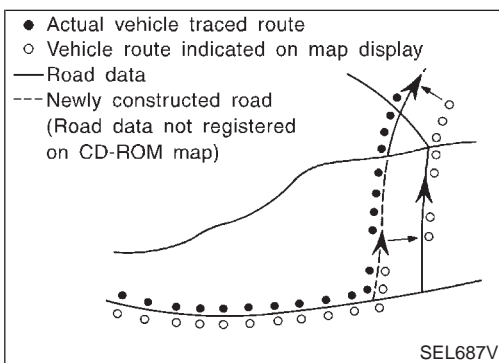
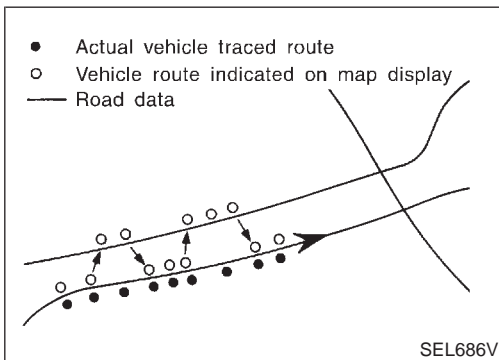
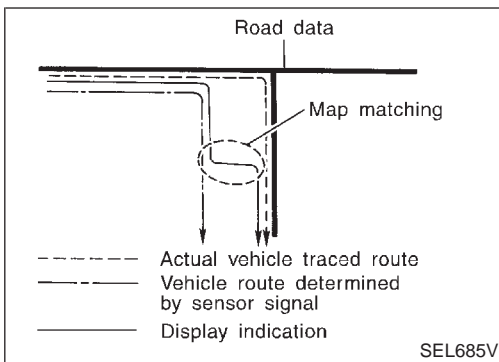

Map Matching

NBEL0228S0102

Map matching allows the driver to compare the sensed vehicle location data with the road map contained in the CD-ROM drive. Vehicle position is marked on the CD-ROM map. This permits the driver to accurately determine his/her present position on the highway and to make appropriate course decisions.

When GPS data reception is poor during travel, the vehicle position is not amended. At this time, manual manipulation of the CD-ROM map position marker is required.

Map matching permits the driver to make priority judgments about possible appropriate roads other than the one currently being traveled.

If there is an error in the distance or direction of travel, there will also be an error in the relative position of other routes. When two routes are closely parallel to one another, the indicated position for both routes will be nearly the same priority. This is so that, slight changes in the steering direction may cause the marker to indicate both routes alternately.

Newly constructed roads may not appear on the CD-ROM map. In this case, map matching is not possible. Changes in the course of a road will also prevent accurate map matching.

When driving on a road not shown on the CD-ROM map, the position marker used for map matching may indicate a different route. Even after returning to a route shown on the map, the position marker may jump to the position currently detected.

GPS (Global Positioning System)

NBEL0228S0103

GPS is the global positioning system developed and operated by the US Department of Defense. GPS satellites (NAVSTAR) transmit radio waves and orbit around the earth at an altitude of approximately 21,000 km (13,000 miles).

GPS receiver calculates the three-dimensional position of the vehicle (latitude, longitude, and altitude from the sea level) by the time difference of the radio wave arriving from more than four GPS satellites (three-dimensional positioning).

When the radio wave is received from only three GPS satellites, the two-dimensional position (latitude and longitude) is calculated, using the altitude from the sea level data calculated by using four GPS satellites (two-dimensional positioning).

Positioning capability is degraded in the following cases.

- In two-dimensional positioning, when the vehicle's altitude from the sea level changes, the precision becomes lower.
- The location detection performance can have an error of about 100 m (300 ft) even in three-dimensional positioning with high precision. Because the precision is influenced by the location of GPS satellites used for positioning, the location detection performance may drop depending on the location of GPS satellites.
- When the radio wave from GPS satellites cannot be received,

GI
MA
EM
LC
EC
FE
AT
TF
PD
AX
SU
BR
ST
RS
BT
HA
SC
EL
IDX

NAVIGATION SYSTEM

System Description (Cont'd)

for example, when the vehicle is in a tunnel, in a parking lot inside building, under an elevated superhighway or near strong power lines, the location may not be detected. Turbulent/electric weather conditions may also affect positioning performance. If something is placed on the antenna, the radio wave from GPS satellites may not be received.

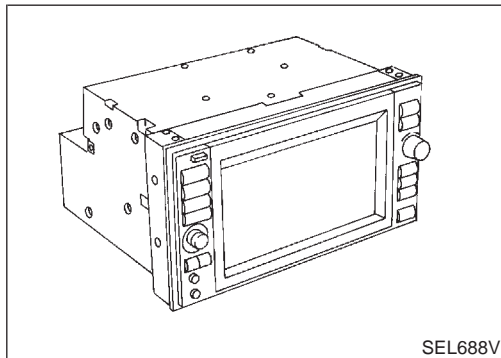

COMPONENT DESCRIPTION

Display & NAVI Control Unit

NBEL0228S02

NBEL0228S0201

- The gyro (angular speed sensor) and the CD-ROM drive are built-in units that control the navigation functions.
- Signals are received from the gyro, the vehicle speed sensor, and the GPS antenna. Vehicle location is determined by combining this data with the data contained in the CD-ROM map. Locational information is shown on liquid crystal display panel.
- Finger-operated touch switches are positioned on the liquid crystal display panel for easy operation.
- The touch switches used to control the equipment are beneath a glass sheet and two resistance membranes at the top of the liquid crystal display panel. The switches are sensitive to resistance value where touched with your finger to detect operating status.

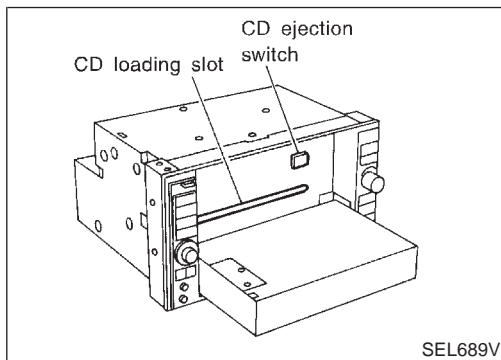

CD-ROM Driver

NBEL0228S0202

Maps, traffic control regulations, and other pertinent information can be easily read from the CD-ROM disc.

NOTE:

- When removing the CD-ROM, allow it to remain open until the liquid crystal display locks.
- The liquid crystal display must be closed when the vehicle is running.
- Do not place cups, cans or other containers containing liquids on top of the liquid crystal display.

Map CD-ROM

NBEL0228S0203

- The map CD-ROM has maps, traffic control regulations, and other pertinent information.
- To improve CD-ROM map matching and route determination functions, the CD-ROM uses an exclusive Nissan format. Therefore, the use of a CD-ROM provided by other manufacturers cannot be used.

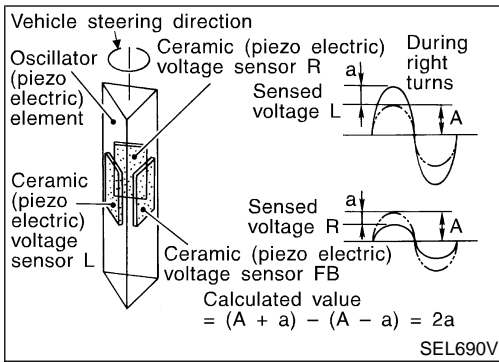

Gyro (Angular Speed Sensor)

NBEL0228S0204

- The oscillator gyro sensor is used to detect changes in vehicle steering angle.
- The oscillator gyro periodically senses oscillatory variation at the oscillation terminals. This variation is caused by changes in the vehicle angular velocity. Voltage variations are sensed by ceramic voltage sensors at the left and right sides of the terminals. Vehicle angular velocity corresponds directly with these changes in voltage.
- The gyro is built into the display & navigation (NAVI) control unit.

GI
MA
EM
LC

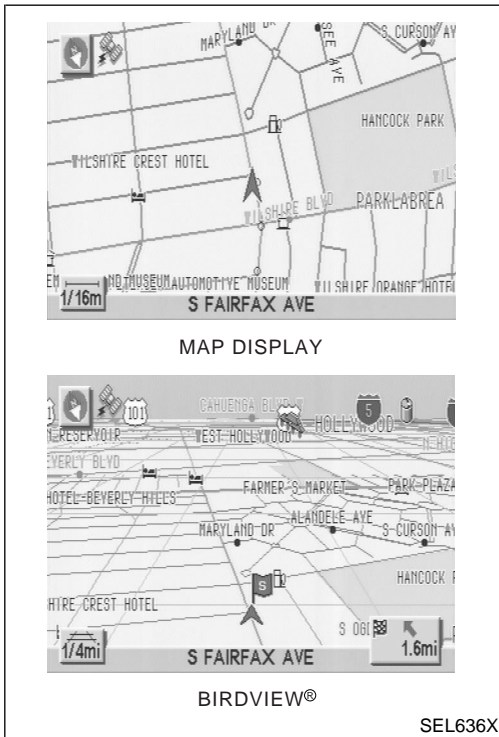

BIRDVIEW®

NBEL0228S0205

The BIRDVIEW® provides a detailed and easily seen display of road conditions covering the vehicle's immediate to distant area.

EC
FE
AT
TF
PD
AX
SU
BR

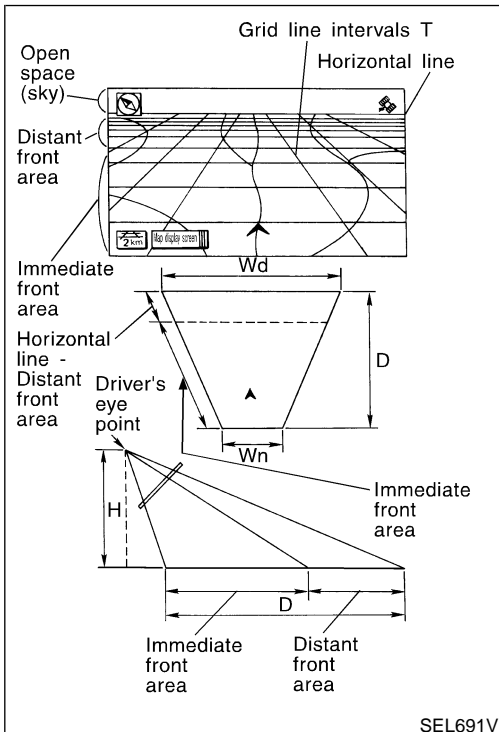

Description

NBEL0228S0206

- Display area: Trapezoidal representation showing approximate distances (W_n , D , and W_d).
- Ten horizontal grid lines indicate display width while six vertical grid lines indicate display depth and direction.
- Drawing line area shows open space, depth, and immediate front area. Each area is to a scale of approximately 5:6:25.
- When the "ZM-" button is pushed, the view point height is increased. Pushing the "ZM+" button decreases the height. Pushing the "ZM-" button or the "ZM+" button during operation indicates the scale change and the view point height at the left-hand side of the screen.

ST
RS
BT
HA
SC

EL

IDX

NAVIGATION SYSTEM

System Description (Cont'd)

FUNCTION OF TOUCH SWITCH (SUMMARY) Display with Pushed "MAP" Switch

=NBEL0228S03

NBEL0228S0301

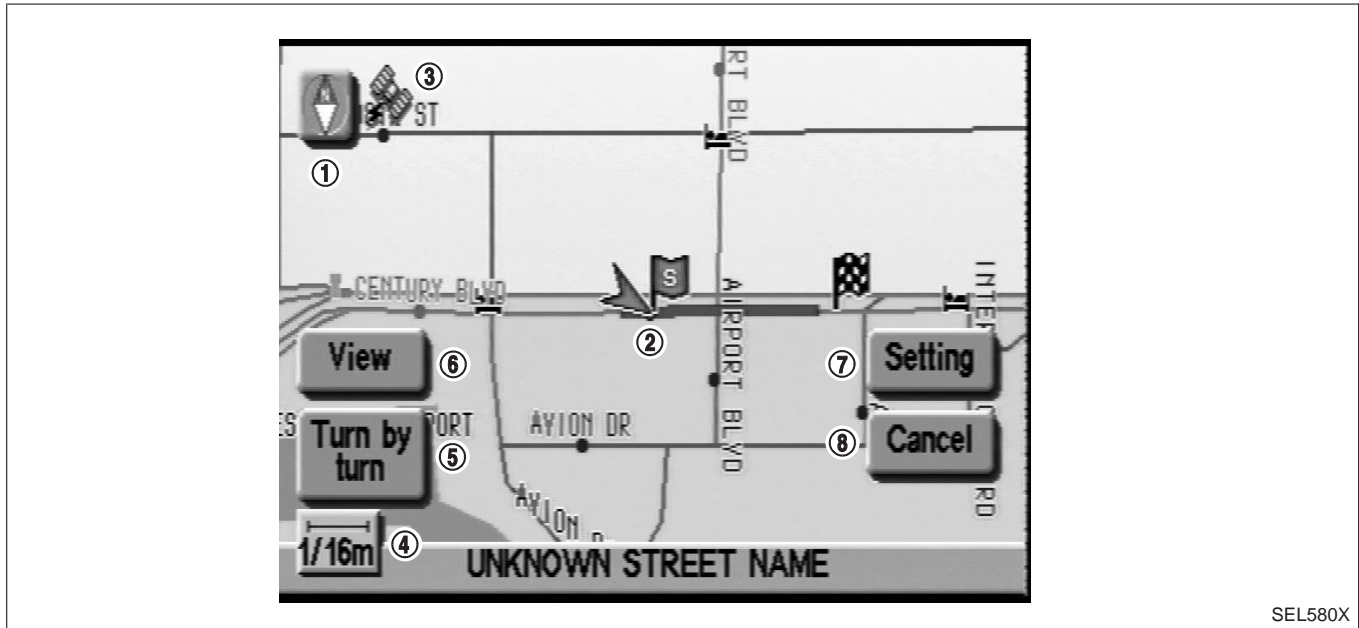

The function of each touch switch is as follows:

- 1) Azimuth indication
- 2) Position marker
The tip of the arrow shows the current position. The shaft of the arrow indicates the direction in which the vehicle is traveling.
- 3) GPS reception signal (indicates current reception conditions)
- 4) Distance display (shows the distance in a reduced scale)
- 5) Current location voice information
(this information is available when the route guide is being activated and the designated route is being traveled.)
- 6) Switch display from map screen to BIRDVIEW[®] screen
(change to map screen on display when the BIRDVIEW[®] is being used.)
- 7) The following items can be set.
 - Save Current Location
 - Edit Address Book
 - Guide Volume
 - System Setting
- 8) The route guide operation can be canceled.

Display with Pushed "DEST" Switch

=NBEL0228S0302

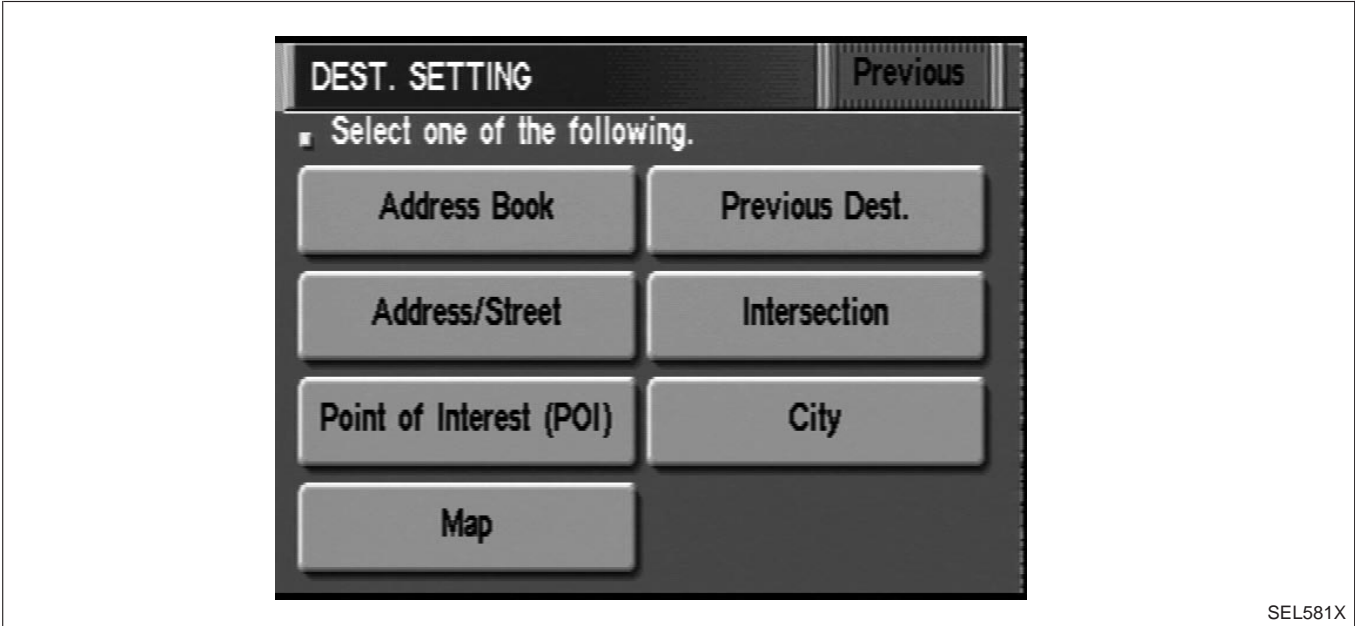

SEL581X

The function of each touch switch is as follows:

Icon	Description
Address Book	Favorite place can be saved to memory. The destination can be selected from the memory.
Address/Street	The destination can be searched from the address.
Point of Interest (POI)	The destination of favorite facility can be searched.
Previous Dest.	The previous ten destinations stored in memory are displayed.
Intersection	The destination from the intersection name can be retrieved.
City	The destination can be searched from city name.
Map	The destination can be searched from the map.

GI

MA

EM

LC

EC

FE

AT

TF

PD

AX

SU

BR

ST

RS

BT

HA

SC

EL

IDX

NAVIGATION SYSTEM

System Description (Cont'd)

Display with Touch Screen

NBEL0228S0303

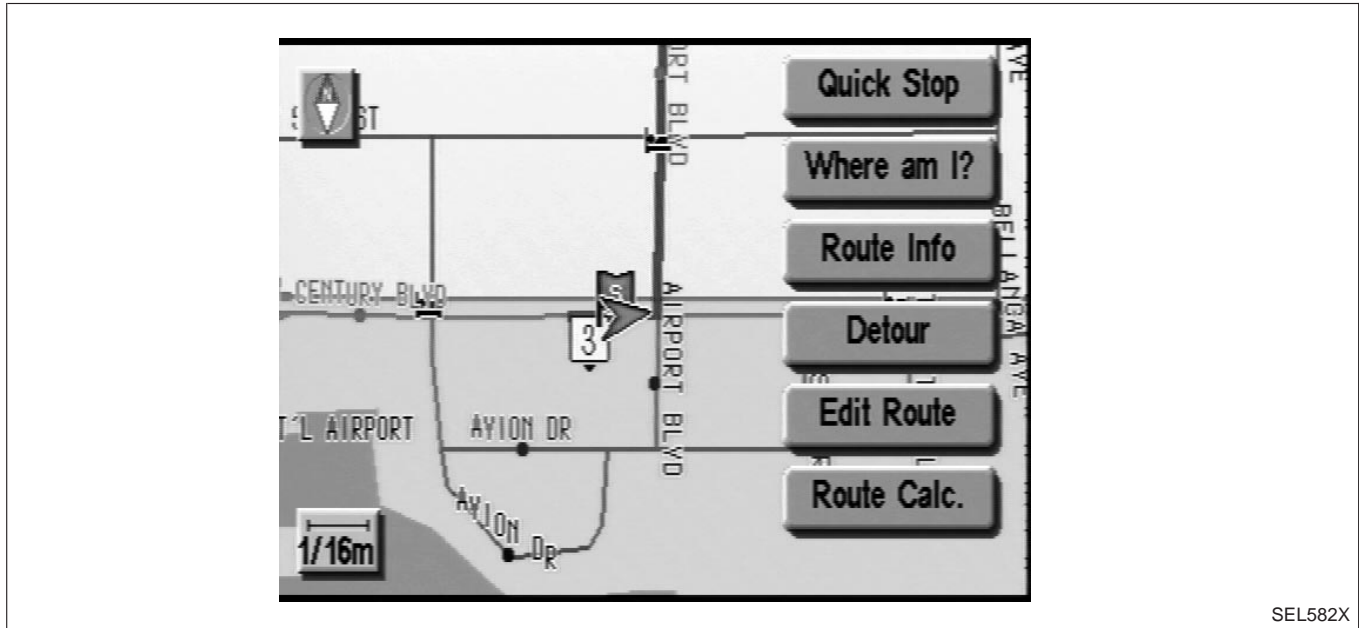

SEL582X

The function of each touch switch is as follows:

Icon	Description
Quick Stop	The selected facility is set as the destination or way-point. (Route guidance has been turned OFF or the destination has been reached.)
Where am I?	Next, current and previous street names can be displayed.
Route Info.*	The following items can be set. <ul style="list-style-type: none"> ● Complete Route ● Turn List ● Route Simulation (Displayed only when the destination area has been set.)
Detour*	Based on the selected distance, an alternative route is searched. [Displayed only when the recommended route (not its reverse) is followed.]
Edit Route*	Change the destination or add the transit points of the route set in the route guide. (Displayed only when the automatic reroute function has been turned OFF and the recommended route is not followed.)
Route Calc.	Search for a recommended route between the vehicle's current location and the destination area. (Displayed only when the destination area has been set.)

*: When destinations have been entered, route guidance has been turned OFF or destination has been reached, "Route Info.", "Detour", "Edit Route" and "Route Calc." are not displayed.

NAVIGATION SYSTEM

Wiring Diagram — NAVI —

Wiring Diagram — NAVI —

NBEL0230

EL-NAVI-01

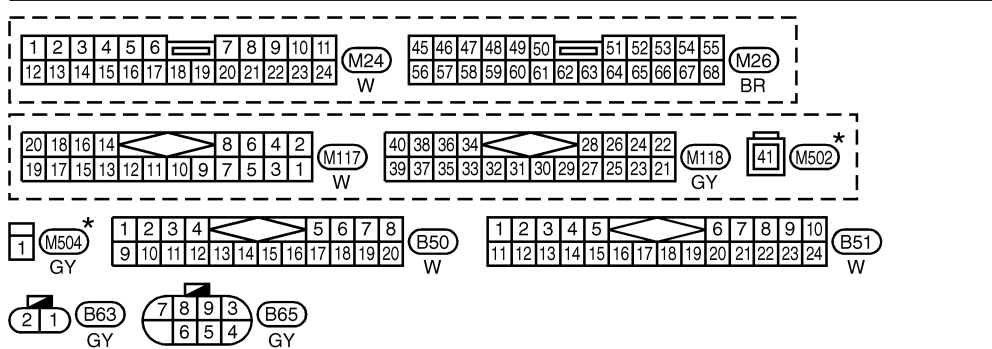
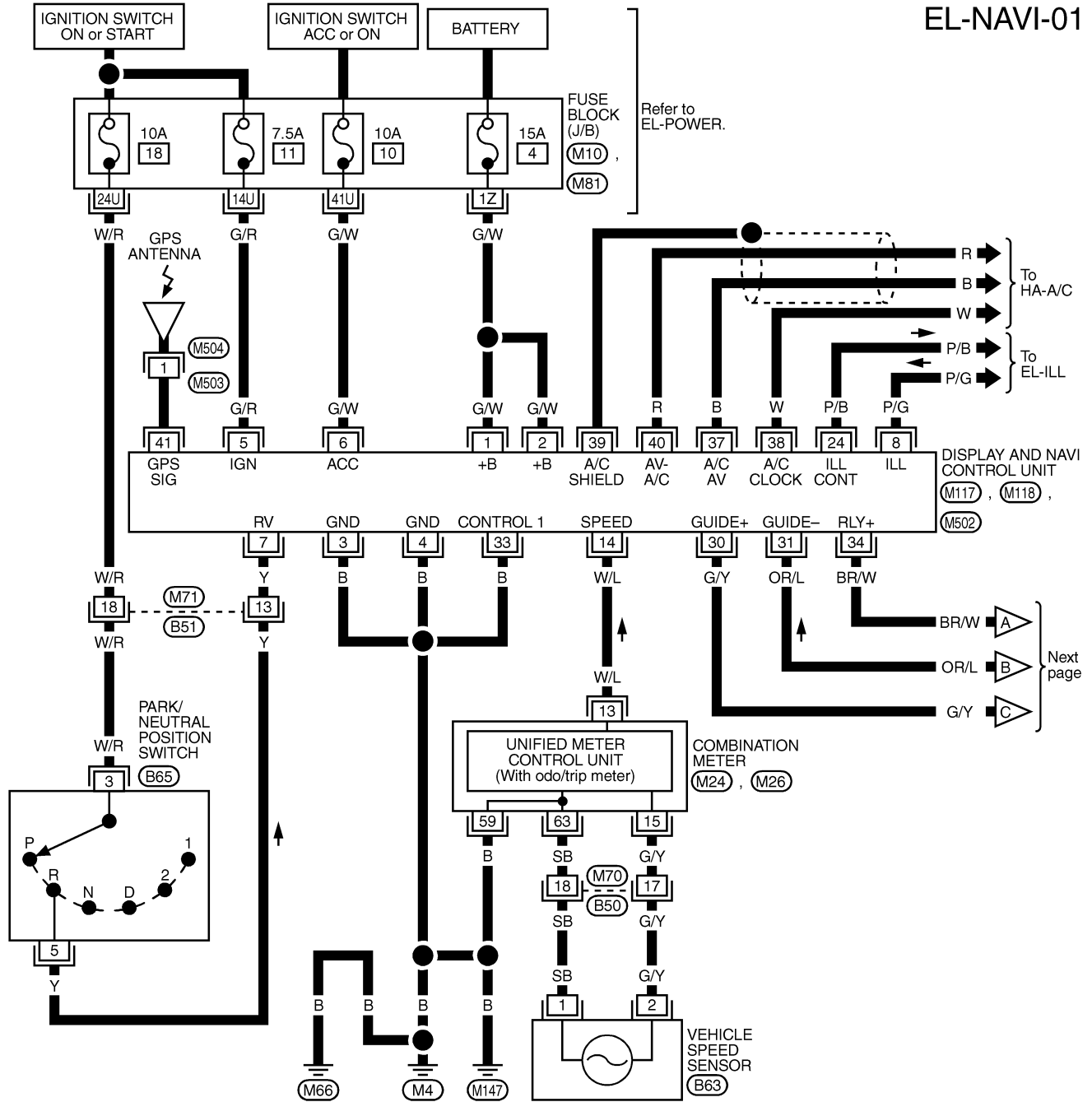

REFER TO THE FOLLOWING.
 (M10), (M81) - FUSE BLOCK-
 JUNCTION BOX (J/B)

* : This connector is not shown in "HARNESS LAYOUT", EL section.

MEL823L

NAVIGATION SYSTEM

Wiring Diagram — NAVI — (Cont'd)

EL-NAVI-02

GI
MA
EM
LC
EC
FE
AT
TF
PD
AX
SU
BR
ST
RS
BT
HA
SC
EL
IDX

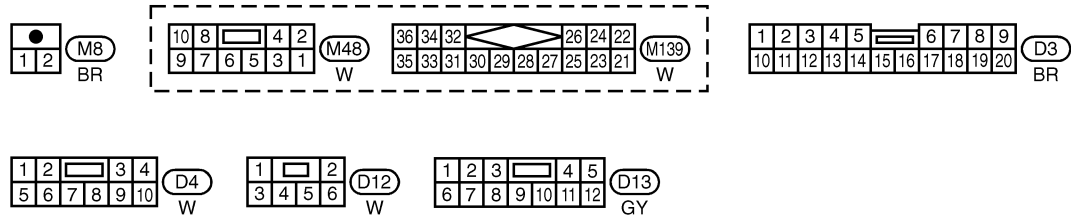
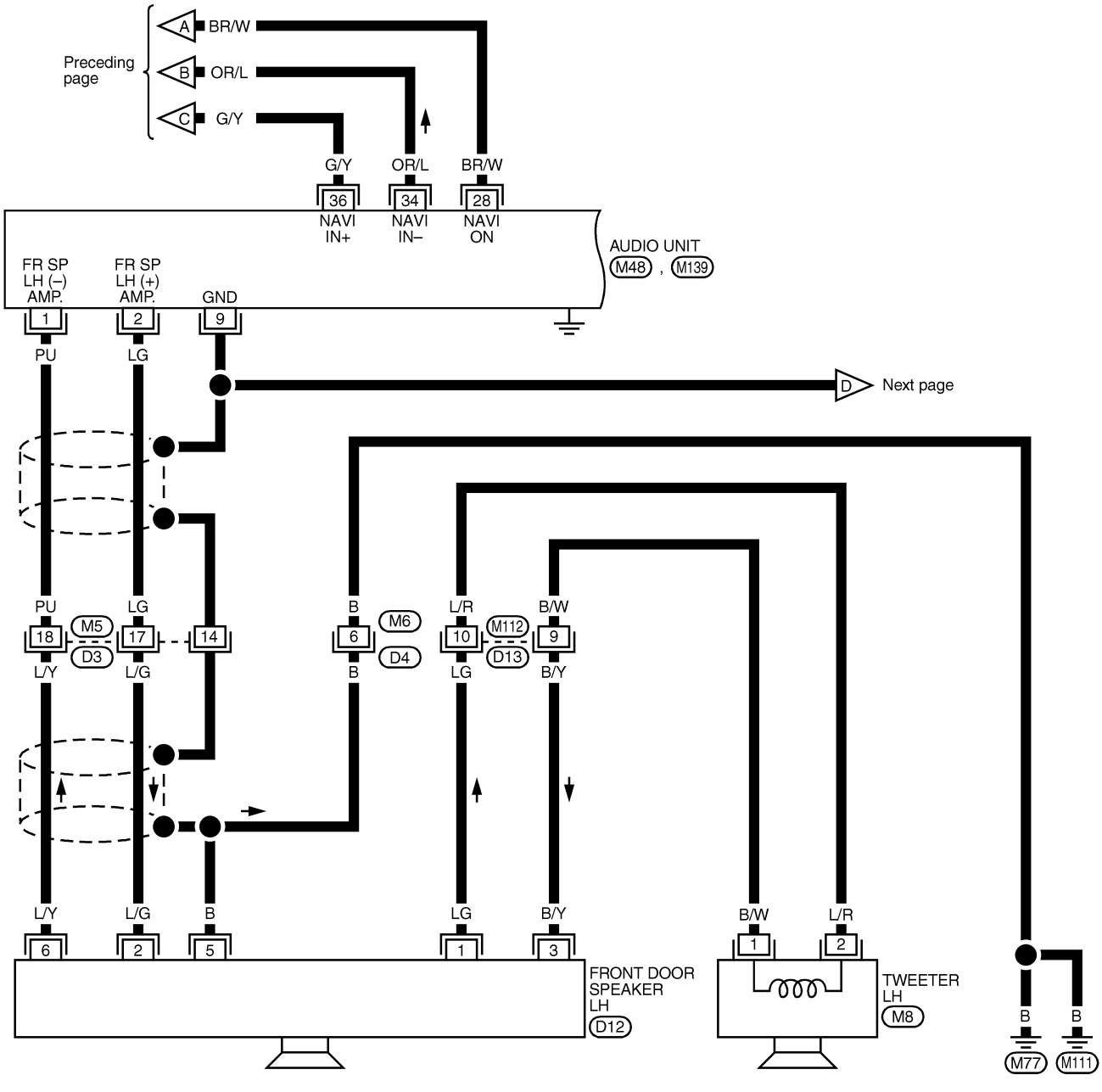

MEL269M

NAVIGATION SYSTEM

Wiring Diagram — NAVI — (Cont'd)

EL-NAVI-03

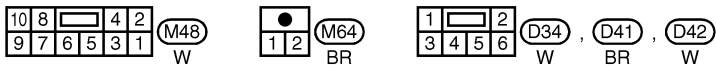
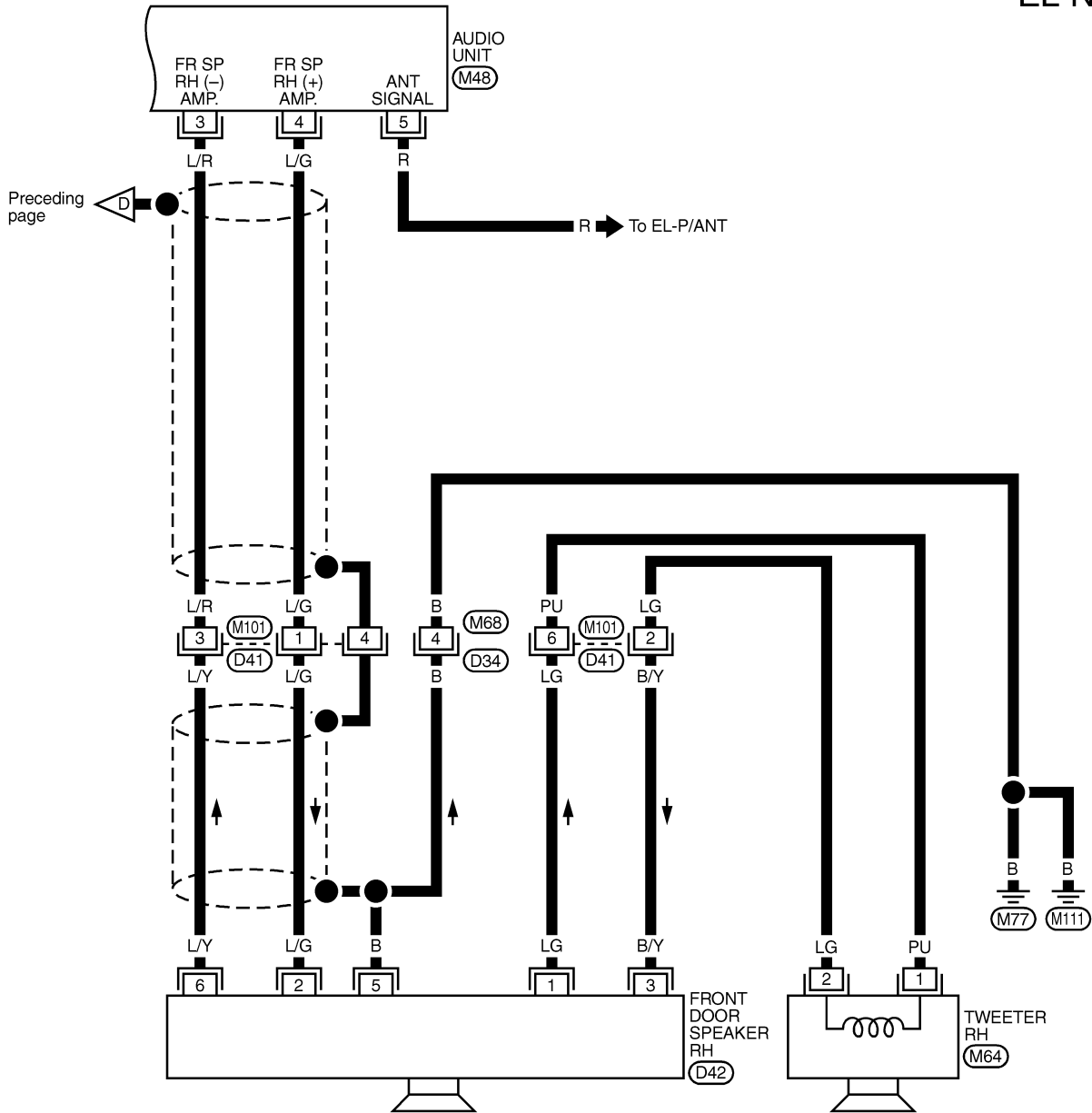

MEL270M

Self-diagnosis Mode APPLICATION ITEMS

NBEL0231

NBEL0231S01

Mode	Description	Reference page	
Self Diagnosis	Self-diagnosis for display & NAVI control unit, CD-ROM and GPS antenna connection.	EL-398	
Confirmation/ adjustment	Display Diagnosis	Color and gray gradation of display can be checked in this mode.	
	Diagnostic Signals from the Car	Several input signals to display & NAVI control unit, can be monitored in this mode.	
	Navigation	Check the map CD-ROM version	The version (parts number) of inserted CD-ROM can be checked in this mode.
		Error history	Diagnosis results previously stored in the memory (before turning ignition switch ON) are displayed in this mode. Time and location when/where the errors occurred are also displayed.
		Longitude & Latitude	Display the map. Use the joystick to adjust position. Longitude and latitude will be displayed.
		Adjust the angle	Turning angle of the vehicle on the display can be adjusted in this mode.
		Speed Calibration	Under ordinary conditions, the navigation system distance measuring function will automatically compensate for minute decreases in wheel and tire diameter caused by tire wear or low pressure. Speed calibration immediately restores system accuracy in cases such as when distance calibration is needed because of the use of tire chains in inclement weather.
Initialize Location	This mode is for initializing the current location. Use when the vehicle is transported a long distance on a trailer, etc.		

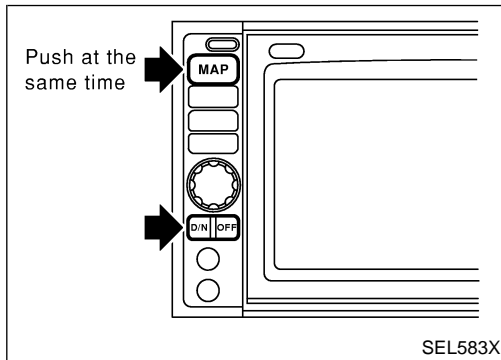

HOW TO PERFORM SELF-DIAGNOSIS MODE

NBEL0231S02

1. Start the engine.
2. Push both of "MAP" and "D/N" switches at the same time for more than 5 seconds.



3. Touch "Self Diagnosis" or "Confirmation/ adjustment".
- For further procedure, refer to the following pages which describe each application item of the self-diagnosis mode.

NAVIGATION SYSTEM

Self-diagnosis Mode (Cont'd)

NBEL0231S0201

“Self Diagnosis”

1. Start the engine.
2. Push both “MAP” and “D/N” switches at the same time for more than 5 seconds.
3. Touch “Self Diagnosis”.

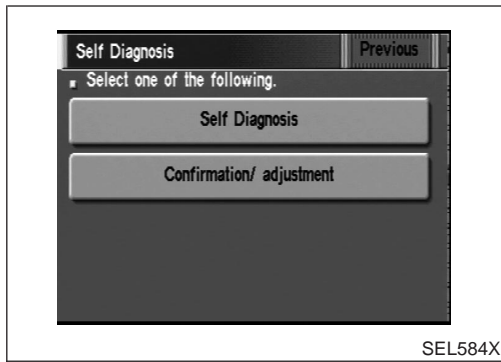

4. Self-diagnosis will be performed.

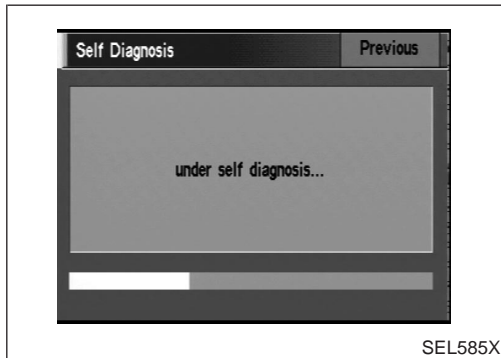

5. Diagnosis results will be displayed. Diagnosis results are indicated by display color. For details refer to “SELF-DIAGNOSIS RESULTS”.

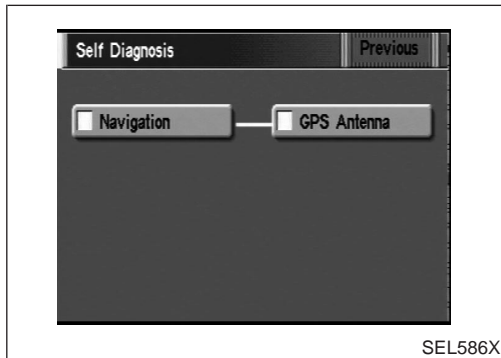

To obtain detailed diagnosis results on the screen, touch “Navigation” or “GPS Antenna”.

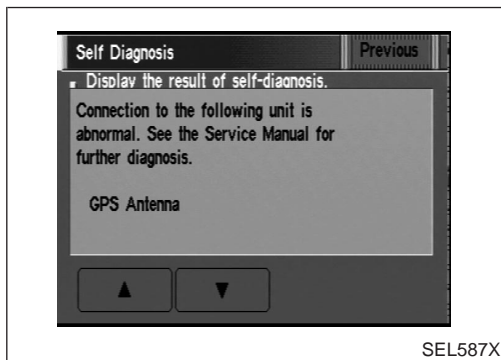

NAVIGATION SYSTEM

Self-diagnosis Mode (Cont'd)

SELF-DIAGNOSIS RESULTS

=NBEL0231S03

Diagnosed item	Displayed color	Detailed result	Description	Diagnoses/service procedure Recheck system at each check or replacement (When malfunction is eliminated, further repair work is not required.)	
“GPS Antenna” (GPS antenna connection)	Green	—	GPS antenna is connected to display & NAVI control unit correctly.	—	GI MA
	Yellow	Connection to the following unit is abnormal. See the Service Manual for further diagnosis.	GPS antenna connection error is detected.	<ol style="list-style-type: none"> 1. Check GPS antenna feeder cable connection at display & NAVI control unit. 2. Visually check GPS antenna feeder cable. If NG, replace GPS antenna assembly. 3. Replace GPS antenna. 	EM LC EC
“Navigation” (Display & NAVI control unit)	Green	—	No failure is detected.	—	FE
	Red	[*** is abnormal.]	Display & NAVI control unit is malfunctioning.	Replace display & NAVI control unit.	AT
	Gray	Self-diagnosis for CD-ROM DRIVER of DISP & NAVI was not conducted due to no insertion of CD-ROM.	Any CD-ROM is not inserted or display & NAVI control unit is malfunctioning.	<ol style="list-style-type: none"> 1. Confirm that map CD-ROM is not inserted into display & NAVI control unit. 2. Replace display & NAVI control unit. 	TF
	Yellow	CD-ROM or CD-ROM DRIVER of DISP & NAVI is abnormal. See the Service Manual for further diagnosis.	Display & NAVI control unit judges that inserted CD-ROM is malfunctioning. Map CD-ROM or CD-ROM driver of the unit is malfunctioning.	<ol style="list-style-type: none"> 1. Confirm the disk is installed correctly (not up side down.) 2. Perform “CD-ROM VERSION CHECK” in EL-405 to confirm whether correct CD-ROM is inserted or not. 3. Check the disk surface. Are there any scratches, abrasions or pits on the surface? 4. Replace the CD-ROM. 5. Replace display & NAVI control unit. 	PD AX
		CD-ROM is abnormal. Please check the disc.	Inserted map CD-ROM can not be read. Map CD-ROM or CD-ROM driver of the unit is malfunctioning.	<ol style="list-style-type: none"> 3. Check the disk surface. Are there any scratches, abrasions or pits on the surface? 4. Replace the CD-ROM. 5. Replace display & NAVI control unit. 	SU BR
		Connection to the following unit is abnormal. See the Service Manual for further diagnosis.	GPS antenna connection error is detected.	<ol style="list-style-type: none"> 1. Check GPS antenna feeder cable connection at display & NAVI control unit. 2. Visually check GPS antenna feeder cable. If NG, replace GPS antenna assembly. 3. Replace GPS antenna. 	ST RS

EL

IDX

Confirmation/Adjustment Mode

=NBEL0232

“ERROR HISTORY” MODE

NBEL0232S01

Description

NBEL0232S0101

In this mode, historical errors of the system are displayed with the following data.

- How many times the error was detected
- The last time data when the error was detected
- The last place where the error was detected

NOTE:

- The number of errors can be counted up to 50 times. More than 51 times will be indicated as 50 times.
- Malfunction of the GPS board (inside the display & NAVI control unit) will result in the display of incorrect time data.
- When an error occurs, an incorrect position marker appears on the display. The accuracy of the display data (position marker) will be affected.

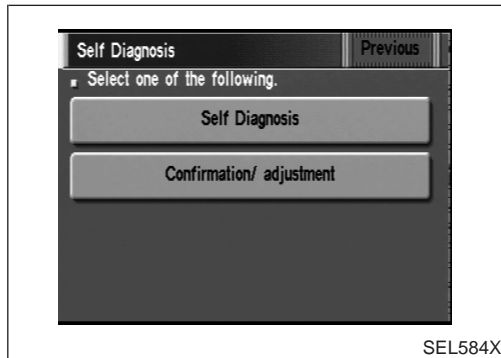

SEL584X

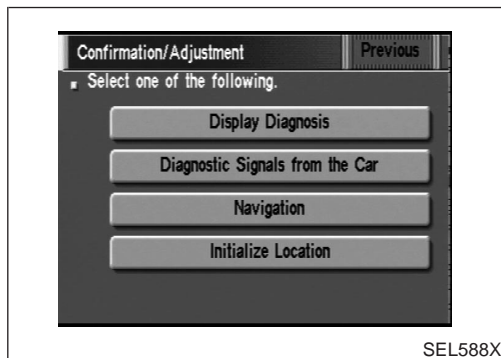

SEL588X

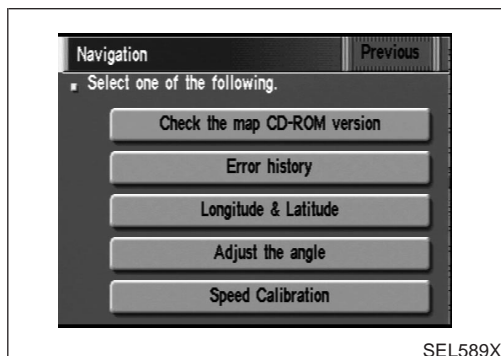

SEL589X

How to Perform

NBEL0232S0102

1. Start the engine.
2. Push both “MAP” and “D/N” switch at the same time for more than 5 seconds.
3. Touch “Confirmation/ adjustment”.
4. Touch “Navigation”.
5. Touch “Error history”.

NAVIGATION SYSTEM

Confirmation/Adjustment Mode (Cont'd)

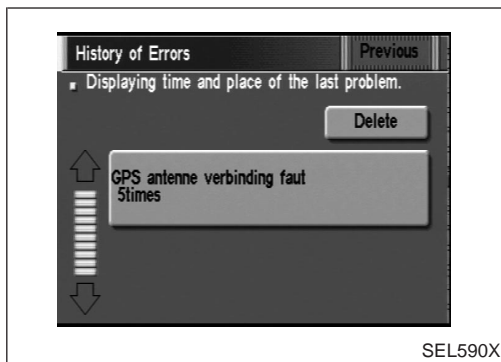

6. If trouble items are displayed with time count, repair/replace the system according to "Error history" TABLE, EL-402.
7. If necessary, touch error item to display the time when the error was detected and the place where the error was detected.
8. After repairing the system, erase the diagnosis memory.

NOTE:

When the display & NAVI control unit must be replaced, do not erase the diagnosis memory for further inspection of malfunctions.

- a. Start the engine.
- b. Push both "Map" and "D/N" switches at the same time for more than 5 seconds.
- c. Touch "Confirmation/ adjustment".
- d. Touch "Navigation".
- e. Touch "Error history".
- f. Touch "Delete".
- g. Touch "Yes".

GI

MA

EM

LC

EC

FE

AT

TF

PD

AX

SU

BR

ST

RS

BT

HA

SC

EL

IDX

NAVIGATION SYSTEM

Confirmation/Adjustment Mode (Cont'd)

“ERROR HISTORY” TABLE

=NBEL0232S02

Detected items	Description	Diagnosis/service procedure	Reference page
Gyro sensor disconnected	Communications malfunction between display & NAVI control unit and internal gyro	Perform self-diagnosis to confirm whether the display & NAVI control unit is malfunctioning or not. If no failure is detected, a momentary and/or temporary malfunction may have been caused by strong electromagnetic wave interference.	EL-397
Connection problem of speed sensor	Input malfunction of display & NAVI control unit and speed sensor	Check vehicle speed sensor signal in “Diagnosis for signals from the car” mode. If the input signal is not detected correctly, check harness for open or short between combination meter and display & NAVI control unit.	EL-404
GPS disconnected	Communications malfunction between display & NAVI control unit and GPS board	Perform self-diagnosis to confirm whether the display & NAVI control unit is malfunctioning or not. If no failure is detected, a momentary and/or temporary malfunction may have been caused by strong electromagnetic wave interference.	EL-397
GPS transmission cable malfunction			
GPS input line connection error			
GPS TCXO over	The transmission circuit of the GPS board frequency synchronization oscillator (inside the display & NAVI control unit) is sending an oscillation frequency that is greater or less than the set value.	A location error occurs. Strong electromagnetic wave interference may have occurred. The GPS antenna may be in a very hot or very cold environment. This is usually a temporary malfunction.	—
GPS TCXO under			
GPS ROM malfunction	Internal malfunction of GPS board RAM or ROM inside the display & NAVI control unit.	Perform self-diagnosis to confirm whether the display & NAVI control unit is malfunctioning or not. If no failure is detected, a momentary and/or temporary malfunction may have been caused by strong electromagnetic wave interference.	EL-397
GPS RAM malfunction			
GPS RTC malfunction	Malfunction of GPS board clock IC inside the display & NAVI control unit.		
GPS antenna disconnected	—	Perform self-diagnosis to confirm GPS antenna connection. If no failure is detected, a momentary and/or temporary malfunction may have been caused by a strong impact.	EL-405
Low voltage of GPS	Power supply voltage for GPS board inside the display & NAVI control unit is low.	1. Check power supply circuits for display & NAVI control unit.	EL-417
		2. Perform self-diagnosis to confirm GPS antenna connection.	EL-397
		3. If above diagnosis results are OK, a momentary and/or temporary malfunction may have been caused by a strong impact.	—
CD-ROM communication error	CD-ROM driver malfunction (inside the display & NAVI control unit)	Perform self-diagnosis to confirm whether the display & NAVI control unit is malfunctioning or not. If no failure is detected, a momentary and/or temporary malfunction may have been caused by strong electromagnetic wave interference.	EL-397

NAVIGATION SYSTEM

Confirmation/Adjustment Mode (Cont'd)

Detected items	Description	Diagnosis/service procedure	Reference page
Loading mechanism malfunction	—	Check that whether the disc can be inserted and ejected correctly. If the loading function does not operate correctly, replace NAVI & display control unit.	—
CD-ROM reading error	It is confirmed that the appropriate CD-ROM disc is positioned in the CD-ROM loader. However, no data can be read.	Perform self-diagnosis to confirm whether the inserted disc is malfunctioning or not.	EL-397
Malfunctioning of error correction for CD-ROM	Erroneous data is read from the CD-ROM. The errors cannot be corrected.		
CD-ROM focus error	CD-ROM data reading beam is out of focus.	Rough road driving might create CD skipping like music CD audio unit.	—
CD-ROM malfunction	—	Perform self-diagnosis to confirm whether the inserted disc is malfunctioning or not.	EL-397

GI

MA

EM

LC

EC

FE

AT

TF

PD

AX

SU

BR

ST

RS

BT

HA

SC

EL

IDX

NAVIGATION SYSTEM

Confirmation/Adjustment Mode (Cont'd)

“DIAGNOSTIC SIGNALS FROM THE CAR” MODE

=NBEL0232S03

Description

NBEL0232S0301

In “Diagnostic Signals From the Car” mode, following input signals to the display & NAVI control unit can be checked on the display.

Item	Indication	Vehicle condition
Vehicle Speed*	ON	Vehicle speed is greater than 0 km/h (0 MPH).
	OFF	Vehicle speed is 0 km/h (0 MPH).
Light	ON	Lighting switch is in 1st or 2nd position.
	OFF	Lighting switch is in “OFF” position.
IGN	ON	Ignition switch is in “ON” position.
	OFF	Ignition switch is in “ACC” position.
REVERSE*	ON	Selector/shift lever is in “Reverse” position.
	OFF	Selector/shift lever is in other than “Reverse” position.

*: When ignition switch is in “ACC” position, indication will be changed to “-”.

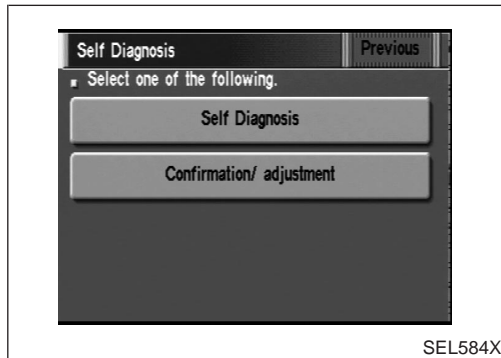

SEL584X

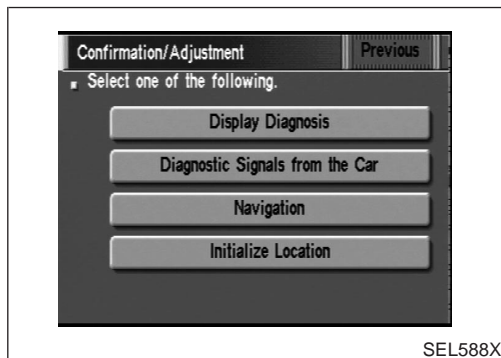

SEL588X

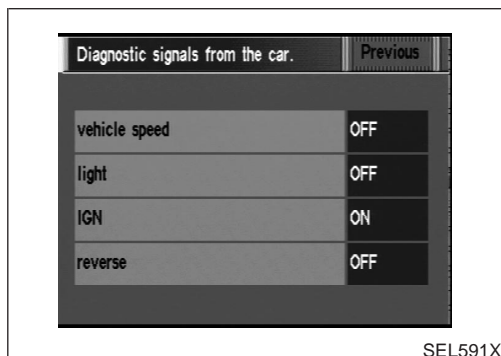

SEL591X

How to Perform

NBEL0232S0302

1. Start the engine.
2. Push both “MAP” and “D/N” switches at the same time for more than 5 seconds.
3. Touch “Confirmation/ adjustment”.
4. Touch “Diagnostic Signals from the Car”.
5. Then “Diagnostic Signals from the Car” mode is performed.

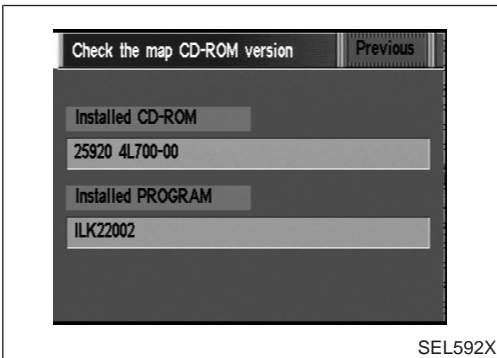
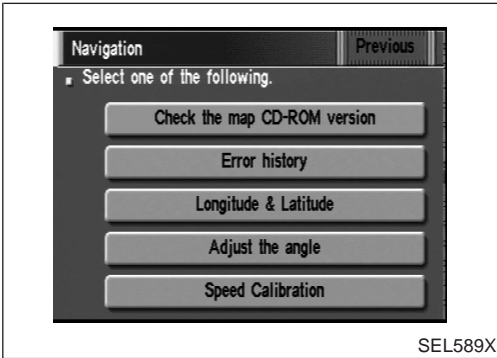
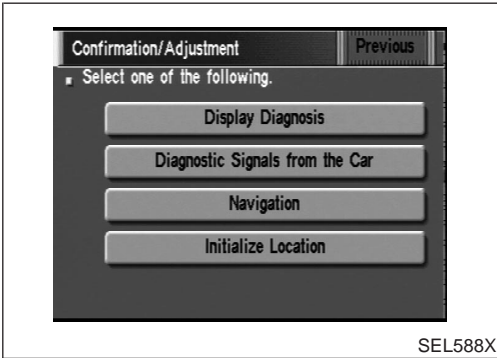
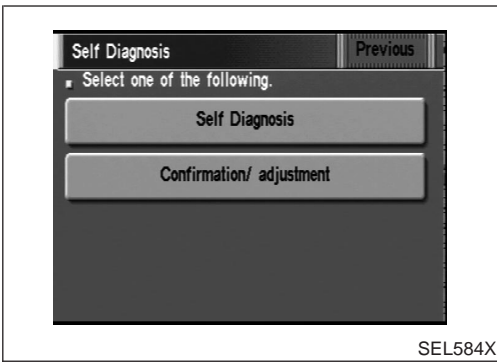

“CHECK THE MAP CD-ROM VERSION” MODE

=NBEL0232S04

NBEL0232S0401

How to Perform

1. Start the engine.
2. Push both “MAP” and “D/N” switches at the same time for more than 5 seconds.
3. Touch “Confirmation/ adjustment”.
4. Touch “Navigation”.
5. Touch “Check the map CD-ROM version”.
6. The version (parts number) of CD-ROM loaded to the display and NAVI control unit will be displayed.

GI

MA

EM

LC

EC

FE

AT

TF

PD

AX

SU

BR

ST

RS

BT

HA

SC

EL

IDX

NAVIGATION SYSTEM

Confirmation/Adjustment Mode (Cont'd)

“DISPLAY DIAGNOSIS” MODE

=NBEL0232S05

Description

NBEL0232S0501

Use the “Diagnosis Display” mode to check the display color brightness and shading. The display & NAVI control unit must be replaced if the color brightness and shading are abnormal.

How to Perform

NBEL0232S0502

1. Start the engine.
2. Push both “MAP” and “D/N” switches at the same time for more than 5 seconds.
3. Touch “Confirmation/ adjustment”.



4. Touch “Display Diagnosis”.

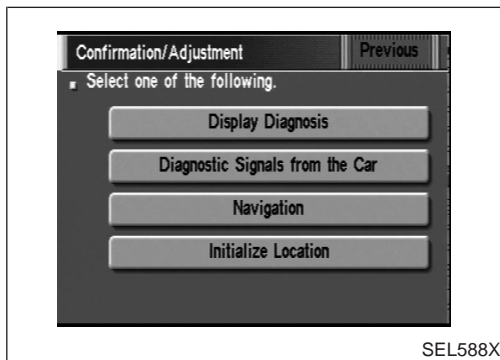

5. Touch “Display color spectrum bar” or “Display gradation bar”.
6. Then color bar/gray scale will be displayed.

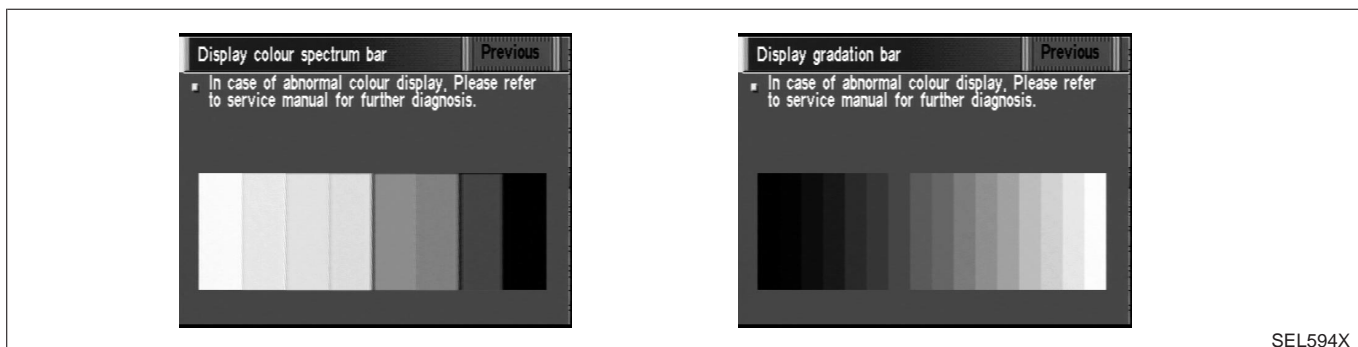
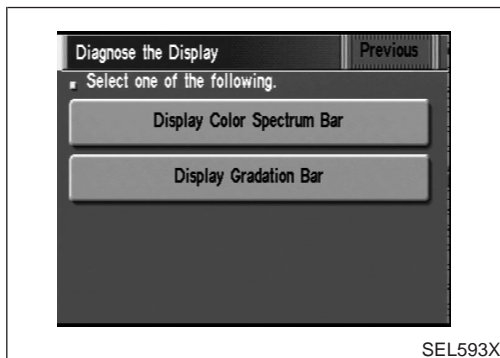

“LONGITUDE & LATITUDE” MODE

Description

The “Longitude & Latitude” is used to confirm the longitude and latitude of some optional area point.

NBEL0232S06

NBEL0232S0601

GI

MA

EM

LC

How to Perform

1. Start the engine.
2. Push both “MAP” and “D/N” switches at the same time for more than 5 seconds.
3. Touch “Confirmation/ adjustment”.

NBEL0232S0602

EC

FE

AT

TF

4. Touch “Navigation”.

PD

AX

SU

BR

5. Touch “Longitude & Latitude”.

ST

RS

BT

HA

6. Adjust the pointer with using the joystick and touch “Set”.
7. The longitude and latitude are displayed.

SC

EL

IDX

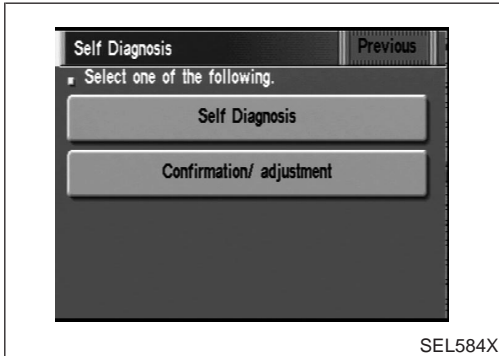

SEL584X

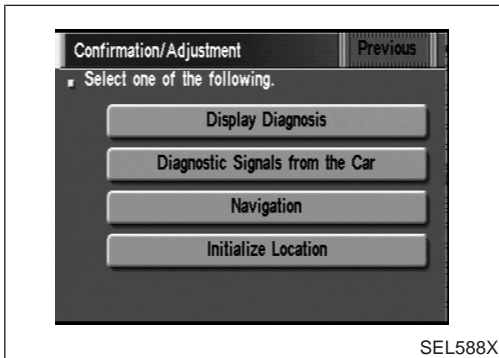

SEL588X

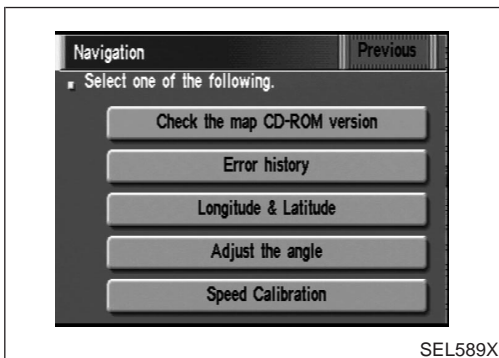

SEL589X

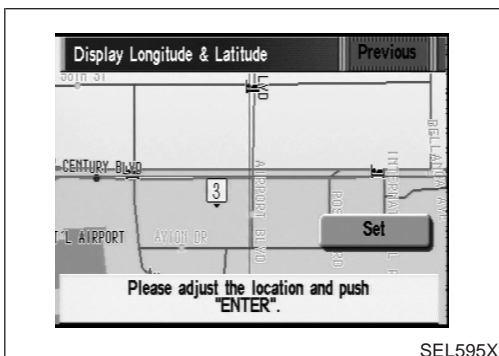

SEL595X

NAVIGATION SYSTEM

Confirmation/Adjustment Mode (Cont'd)

“ADJUST THE ANGLE” MODE

=NBEL0232S07

Description

NBEL0232S0701

If the display indicates a larger or smaller turning angle than the actual turning angle, the gyro (angular speed sensor) sensing values must be checked.

In case that the vehicle on the display makes larger angle turn than reality, touch “-”. In case that the vehicle on the display makes smaller angle turn than reality, touch “+”.

How to Perform

NBEL0232S0702

1. Start the engine.
2. Push both “MAP” and “D/N” switches at the same time for more than 5 seconds.
3. Touch “Confirmation/ adjustment”.

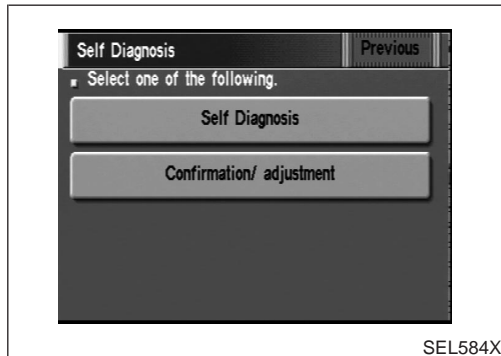

4. Touch “Navigation”.

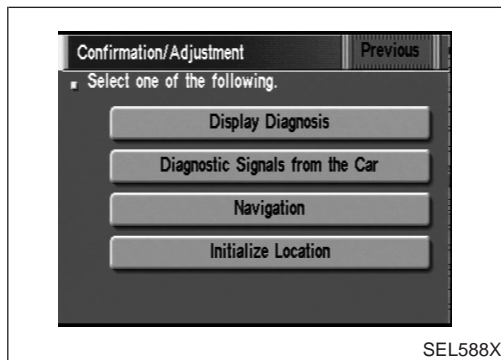

5. Touch “Adjust the angle”.

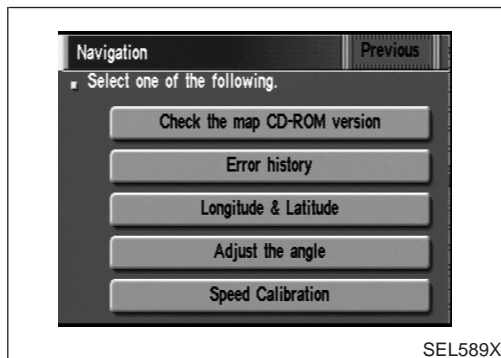

6. Touch “Left Turn” to adjust the angle to the left. Touch “Right Turn” to adjust the angle to the right.
7. Touch “+” to increase the angle change coefficient or “-” to reduce the angle change coefficient.
8. Touch “Set” to save the changed values in memory.
9. Then the vehicle turning angle on the display has adjusted.

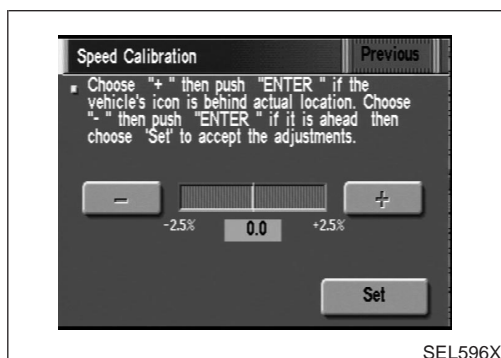

=NBEL0232S08

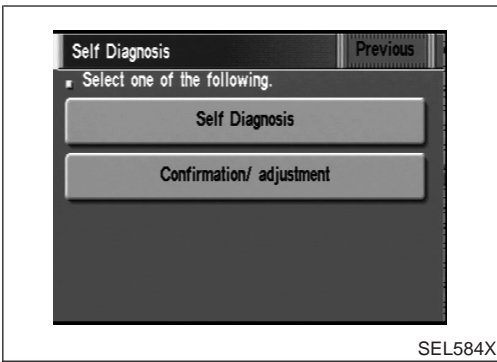

SPEED CALIBRATION

1. Start the engine.
2. Push both "MAP" and "D/N" switches at the same time for more than 5 seconds.
3. Touch "Confirmation/ adjustment".
4. Touch "Navigation".

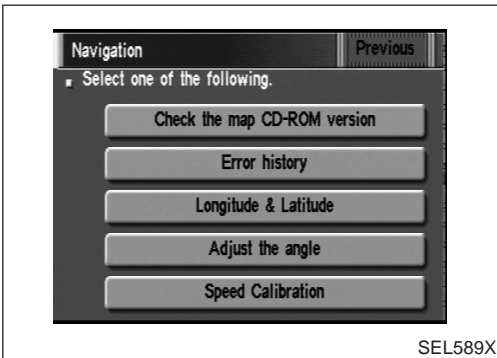

5. Touch "Speed Calibration".

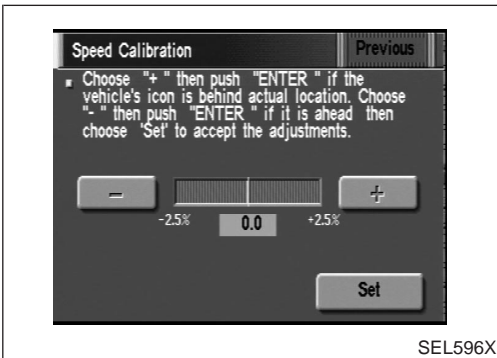

6. Touch "+" or "-" to adjust the distance change coefficient.
 - To make the distance change coefficient smaller, touch "-".
 - To make the distance change coefficient larger, touch "+".
7. Touch "Set".

GI

MA

EM

LC

EC

FE

AT

TF

PD

AX

SU

BR

ST

RS

BT

HA

SC

EL

IDX

NAVIGATION SYSTEM

Setting Mode

Setting Mode APPLICATION ITEMS

=NBEL0233

NBEL0233S01

Mode	Description	Reference page
GPS Information	The GPS includes longitude, latitude and altitude (distance above sea level) of the present vehicle position, and current date and time for the area in which the vehicle is being driven. Also indicated are the GPS reception conditions and the GPS satellite position.	EL-410
Quick Stop Customer Setting	One facility of your selection can be added to your Quick Stop.	EL-413
Route Priorities	Priorities of search request and automatic re-searching can be set for route search.	EL-414
Tracking	Tracking to the present vehicle position can be displayed.	EL-414
Display Setting	The following display settings can be customized. <ul style="list-style-type: none"> ● Display color (Day mode or Night mode) ● Brightness of display 	EL-412
Heading	Heading of the map display can be customized for either north heading or the actual driving direction of the vehicle.	EL-415
Nearby Display Icons	Icons of facilities can be displayed. Facilities to be displayed can be selected from the variety of selections.	EL-416
Adjust Current Location	Current location of position marker can be adjusted. Direction of position marker also can be calibrated when heading direction of the vehicle on the display is not matched with the actual direction.	EL-411
Avoid Area Setting	Particular area can be avoided when routing.	—
Beep On/Off	Beep sounds which correspond to the system operation can be activated/deactivated.	EL-412
Clear Memory	Address book, Previous destination or Avoid area can be deleted.	EL-416

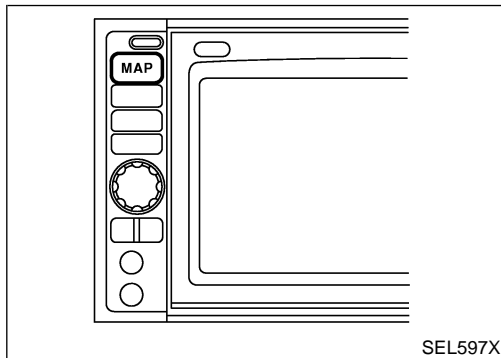

SEL597X

HOW TO PERFORM CONTROL PANEL MODE

NBEL0233S02

1. Start the engine.
2. Push "MAP" switch.
 - For further procedures, refer to the following pages which describe each application item of the control panel mode.

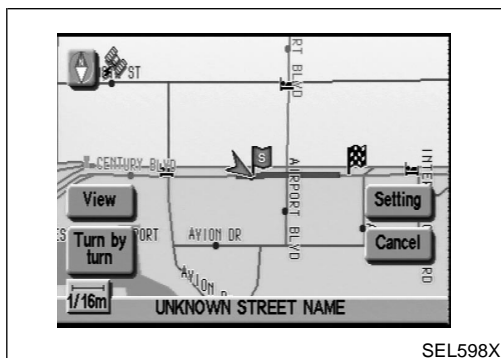

SEL598X

"GPS INFORMATION" SETTING

NBEL0233S03

1. Start the engine.
2. Push "MAP" switch.
3. Touch "Setting".



SEL599X

4. Touch "System Setting".

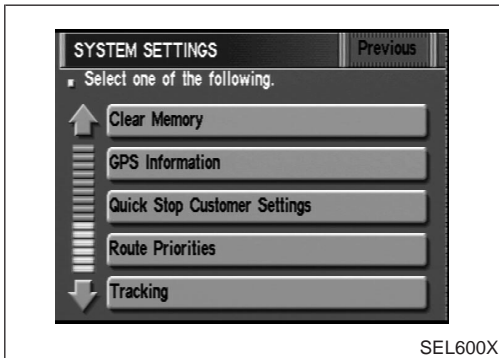

SEL600X

5. Touch "GPS Information".

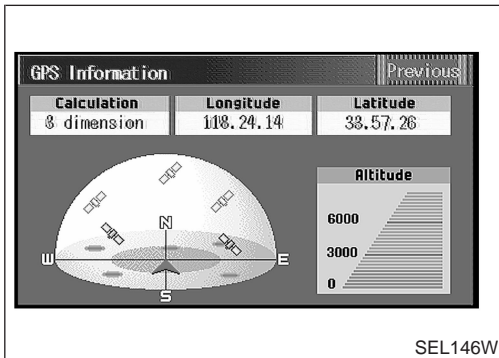

SEL146W

6. Then GPS information will be displayed.

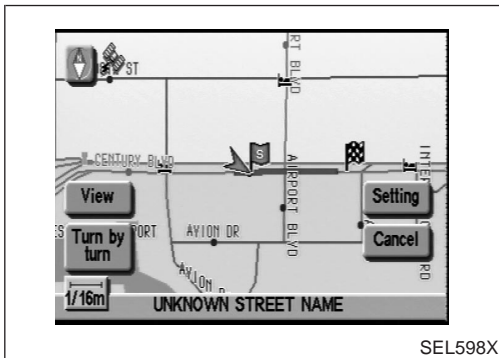

SEL598X

"ADJUST CURRENT LOCATION" SETTING

NBEL0233S04

1. Start the engine.
2. Push "MAP" switch.
3. Touch "Setting".
4. Touch "System Setting".

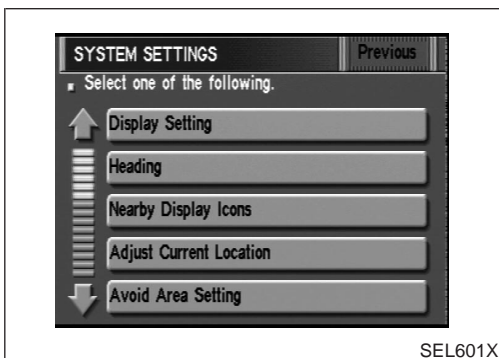

SEL601X

5. Touch "Adjust Current Location".

GI

MA

EM

LC

EC

FE

AT

TF

PD

AX

SU

BR

ST

RS

BT

HA

SC

EL

IDX

NAVIGATION SYSTEM

Setting Mode (Cont'd)

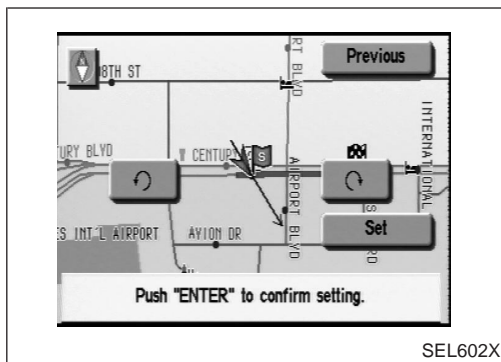

6. Touch “↶” or “↷” to calibrate the heading direction. (Arrow marks will rotate corresponding to the calibration key.)
7. Touch “Set”. Then the vehicle mark will be matched to the arrow mark.
8. Display will show “Heading direction has been calibrated” and then go back to the current location map.

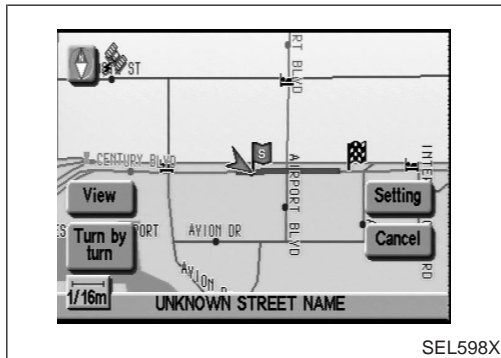

BEEP ON/OFF SETTING

NBEL0233S05

1. Start the engine.
2. Push “MAP” switch.
3. Touch “Setting”.
4. Touch “System Setting”.

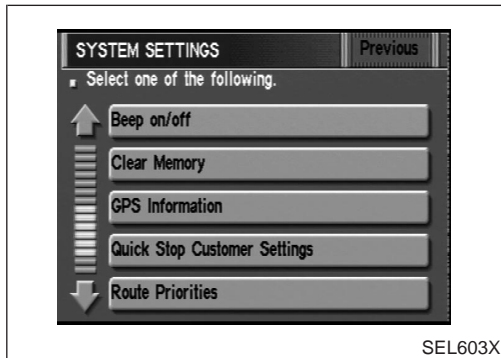

5. Touch “Beep on/off”.

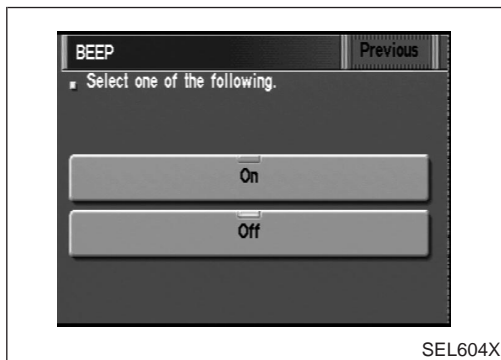

6. Touch “On” or “Off” icon.
 - If you want the beep sound, select “ON”.
 - If you do not want the beep sound, select “OFF”.
7. Push “MAP” switch, then the display will go back to the current location map.

DISPLAY SETTING

NBEL0233S06

Description

NBEL0233S0601

The following display setting can be changed in this mode.

- Dimmer operation (when lighting switch is turned on.)
- Display color (Day mode or Night mode)
- Brightness of display

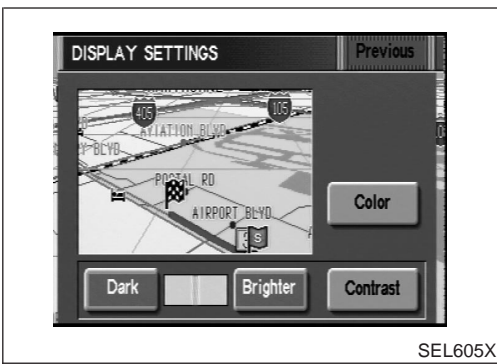

SEL605X

DISPLAY COLOR SETTING

NBEL0233S07

1. Start the engine.
2. Push "MAP" switch.
3. Touch "Setting".
4. Touch "System Setting".
5. Touch "Color". Display color will change to Day mode/Night mode.
6. Touch "Previous".

NOTE:

- Display color can be changed independently when lighting switch is turned on and off.
- Initial setting of the color is as follows:
 When lighting switch is turned off: Day mode
 When lighting switch is turned on: Night mode
 Day mode: White background
 Night mode: Black background

GI

MA

EM

LC

EC

FE

AT

TF

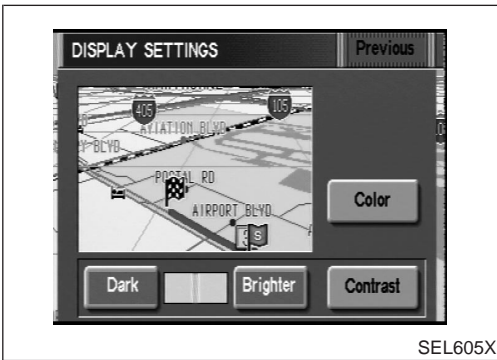

SEL605X

BRIGHTNESS SETTING

NBEL0233S08

1. Start the engine.
2. Push "MAP" switch.
3. Touch "Setting".
4. Touch "System Setting".
5. Touch "Bright" or "Dark" to adjust the brightness of display.
6. Touch "Previous".

NOTE:

Display brightness can be adjusted independently when lighting switch is turned on and off.

PD

AX

SU

BR

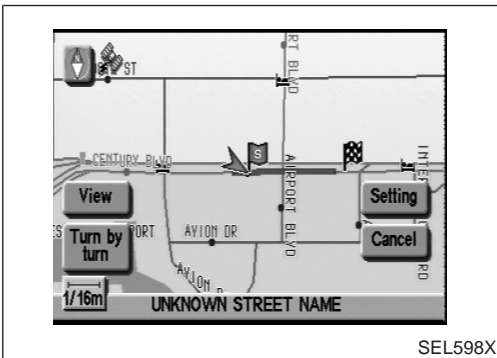

SEL598X

"QUICK STOP CUSTOMER SETTING" MODE

NBEL0233S09

1. Start the engine.
2. Push the "MAP" switch.
3. Touch "Setting".
4. Touch "System Setting".

5. Touch "Quick Stop Customer Setting".

ST

RS

BT

HA

SC

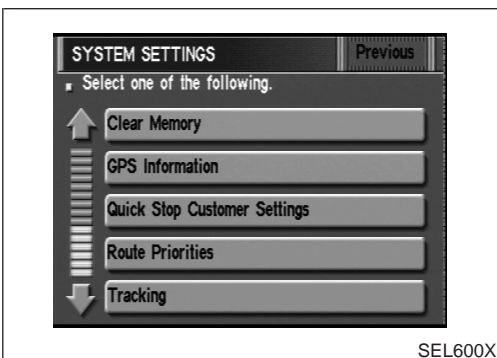

SEL600X

EL

IDX

NAVIGATION SYSTEM

Setting Mode (Cont'd)



6. Select from the itemized list.

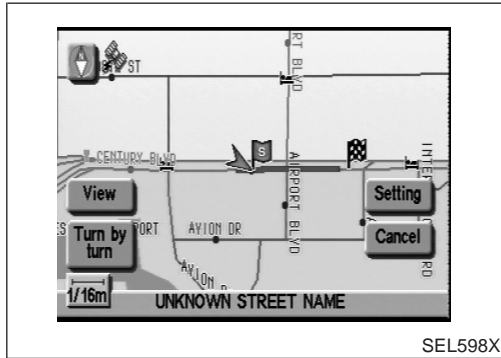

“ROUTE PRIORITIES” MODE

NBEL0233S10

1. Start the engine.
2. Push the “MAP” switch.
3. Touch “Setting”.
4. Touch “System Setting”.

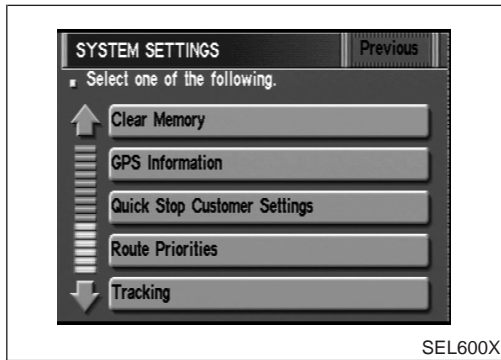

5. Touch “Route Priorities”.

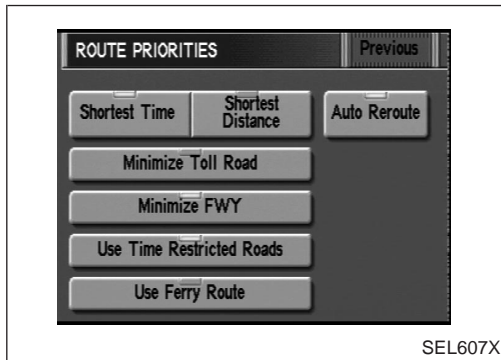

6. Select from the itemized list.

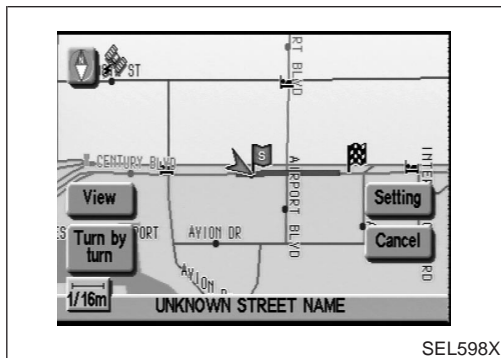

“TRACKING” MODE

NBEL0233S11

1. Start the engine.
2. Push the “MAP” switch.
3. Touch “Setting”.
4. Touch “System Setting”.

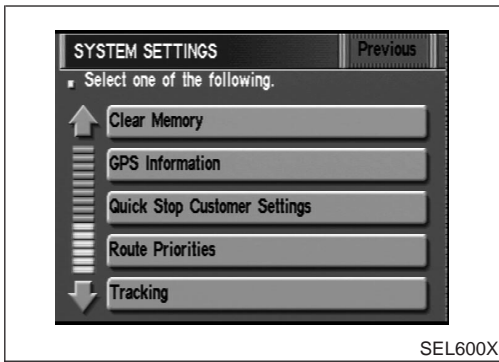

5. Touch "Tracking".

GI

MA

EM

LC

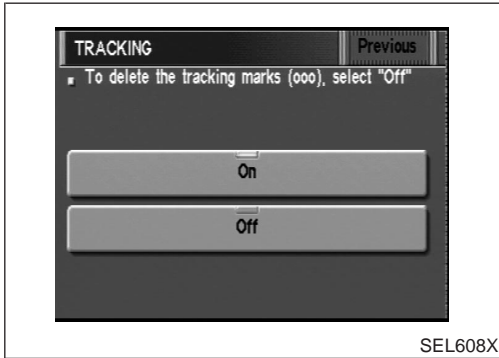

6. Touch the "On" or "Off" icon.

EC

- If you don't need a trail on the map, select "Off".
- If you need a trail on the map, select "On".

7. Push the "MAP" switch to return the display to the current location map.

FE

NOTE:

When a trail display is turned OFF, trail data is erased from the memory.

AT

TF

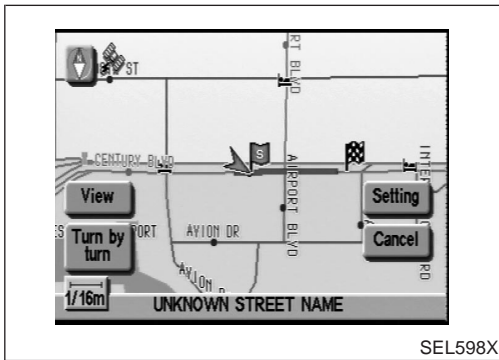

"HEADING" MODE

NBEL0233S12

1. Start the engine.
2. Push the "MAP" switch.
3. Touch "Setting".
4. Touch "System Setting".

PD

AX

SU

BR

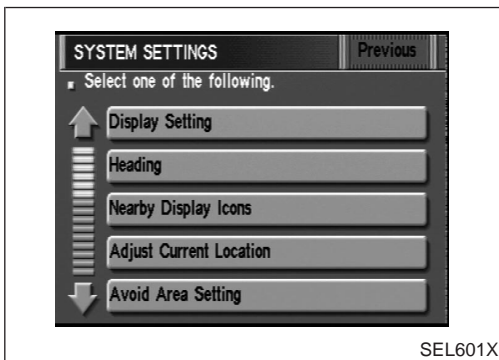

5. Touch "Heading".

ST

RS

BT

HA

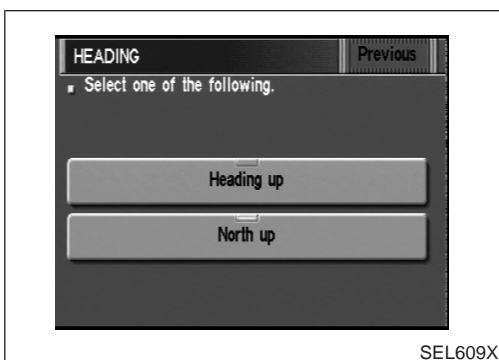

6. Touch the "Heading up" or "North up" icon.

SC

- To display North up, select "North up".
- To display the car heading up, select "Heading up".

7. Push the "MAP" switch, then the display will go back to the current location map.

EL

IDX

NAVIGATION SYSTEM

Setting Mode (Cont'd)

NBEL0233S13

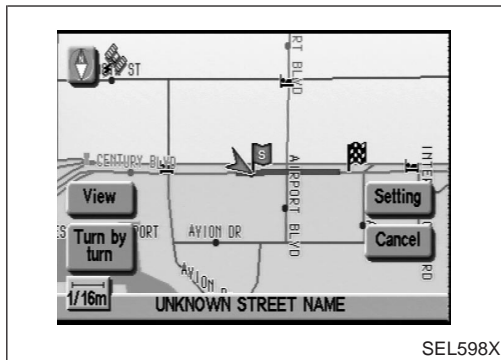

“NEARBY DISPLAY ICONS” MODE

1. Start the engine.
2. Push the “MAP” switch.
3. Touch “Setting”.
4. Touch “System Setting”.

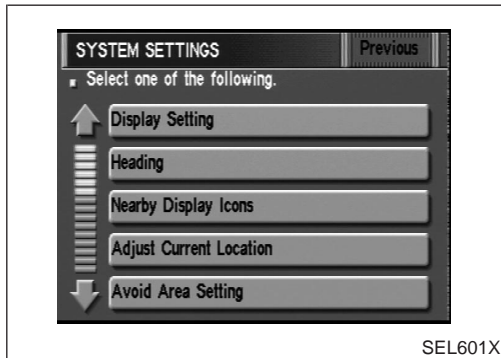

5. Touch “Nearby Display Icons”.

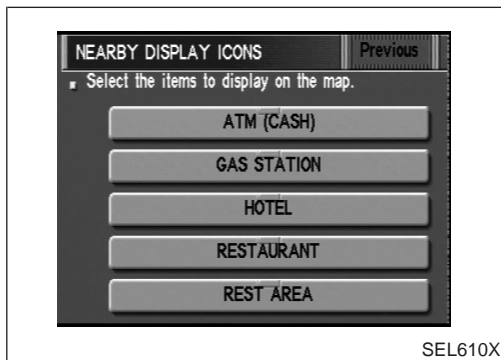

6. Select and touch the itemized list.
7. Push the “MAP” switch to return the display to the current location map.

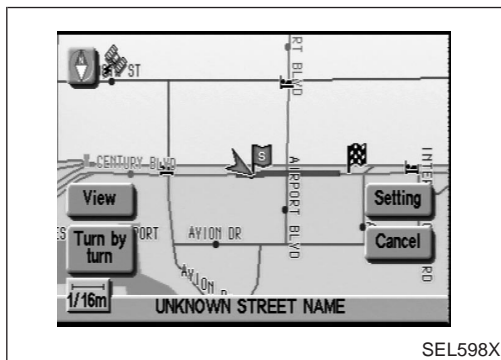

“CLEAR MEMORY” MODE

NBEL0233S14

1. Start the engine.
2. Push the “MAP” switch.
3. Touch “Setting”.
4. Touch “System Setting”.

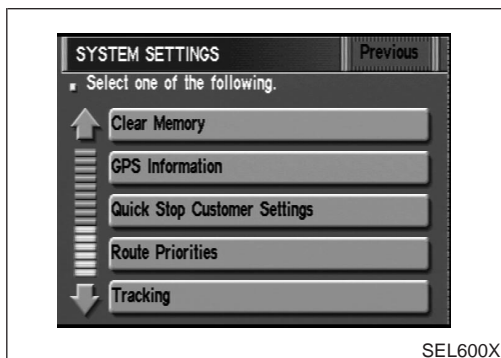

5. Touch “Clear Memory”.



6. To delete all the stored places in the “Address Book”, “Avoid Area” and “Previous Dest.”, select “Yes”.

GI
MA
EM
LC

Trouble diagnoses SYMPTOM CHART

NBEL0234

NBEL0234S01

EC

Symptom	Diagnoses/service procedure	Reference page
Any function of the system does not operate.	Check power supply and ground circuit for display & NAVI control unit.	EL-420
Strange screen color or unusual screen brightness.	1. Check “DISPLAY SETTING”.	EL-412
	2. Check display in “Diagnosis of Display” MODE.	—
The display is not dimmed when turning lighting switch to ON.	1. Check “DISPLAY SETTING”.	EL-412
	2. Check lighting switch signal input to display & NAVI control unit correctly in “Diagnosis for the signals from the car” MODE.	EL-404
No navigation guide voice are heard from both front speakers.	1. Check “Voice Guidance Setting”.	—
	2. Check voice guide operation.	EL-421
Beep does not sound when the system guides route.	Check “BEEP ON/OFF SETTING”.	EL-412
Position marker does not trace along the route being traveled.	Go to “WORK FLOW FOR NAVIGATION INSPECTION”.	EL-418
Position marker does not indicate forward or backward movement.	Check reverse signal input to display & NAVI control unit correctly by “Diagnosis for the signals from the car” MODE.	EL-404
Radio wave of GPS cannot be received. (GPS marker on the display does not become green color.)	1. Is there anything obstructing the GPS antenna on the rear parcel finisher? (GPS antenna located under the rear parcel finisher.)	—
	2. Check GPS radio wave receive condition in “GPS INFORMATION SETTING”.	EL-410
	3. Check GPS antenna in “Self Diagnosis” MODE.	EL-397
Heading direction of position marker does not match vehicle direction.	1. Perform “ADJUST CURRENT LOCATION” SETTING.	EL-411
	2. Go to “WORK FLOW FOR NAVIGATION INSPECTION”.	EL-418
Stored location in the address book and other memory functions are lost when battery is disconnected or becomes discharged.	Stored location in the address book and other memory functions may be lost if the battery is disconnected or becomes discharged. If this should occur, charge or replace the battery as necessary and re-enter the information.	—
Map appears grey and cannot be scrolled.	The current location in the memory is out of the map data area. Perform “Initialize Location”.	EL-433

FE

AT

TF

PD

AX

SU

BR

ST

RS

BT

HA

SC

EL

IDX

NAVIGATION SYSTEM

Trouble diagnoses (Cont'd)

WORK FLOW FOR NAVIGATION INSPECTION

NBEL0234S02

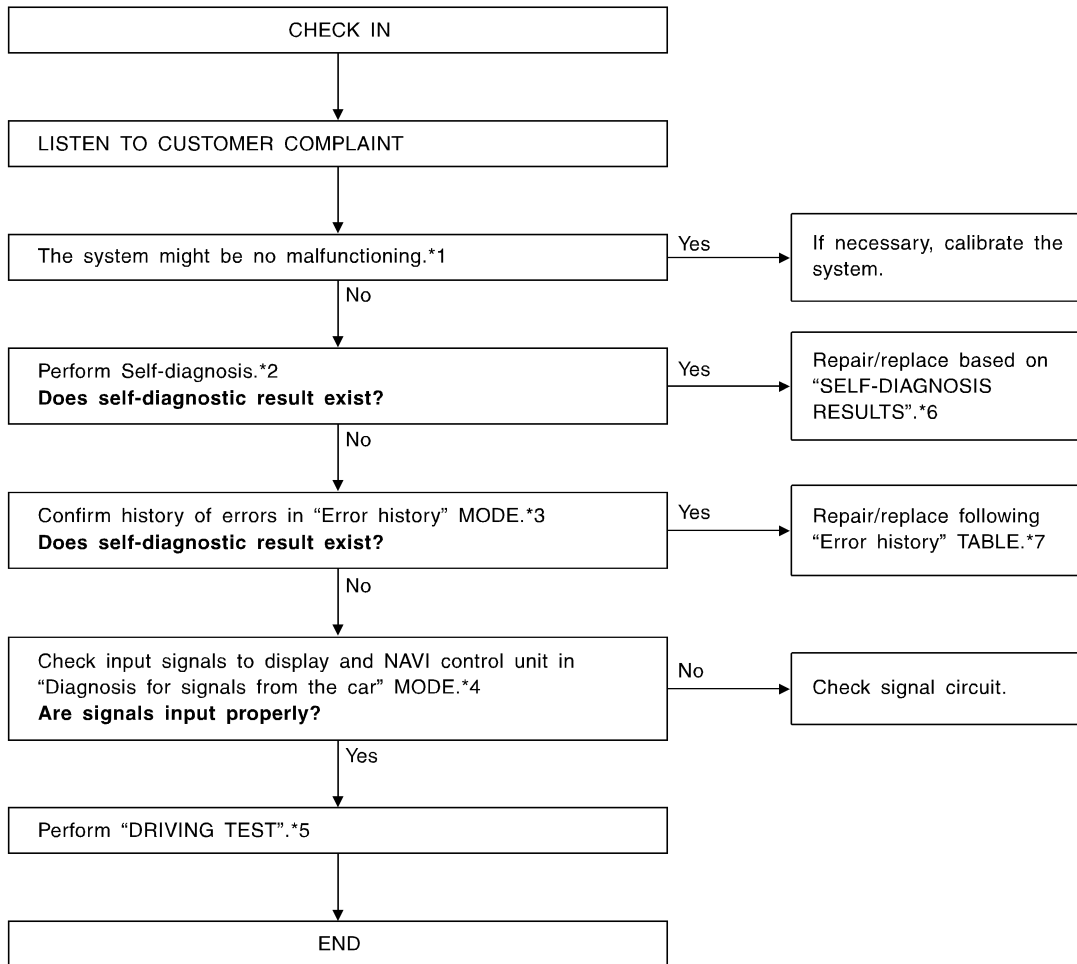

SEL629X

*1: EL-423

*2: EL-397

*3: EL-400

*4: EL-404

*5: EL-419

*6: EL-399

*7: EL-402

DRIVING TEST

During the driving test, diagnose the system by checking the difference of symptoms with each sensor ON or OFF. =NBEL0234S03

Test pattern 1

Test method in which current position adjustment is not made according to GPS data.

- Remove the GPS antenna connector from the display & NAVI control unit. Drive the vehicle.
Before driving the vehicle, perform "ADJUST CURRENT LOCATION" (EL-411).

Test pattern 2

Test procedure in which map matching is not used.

- Before driving the vehicle, perform "ADJUST CURRENT LOCATION" (EL-411). With the ignition switch OFF and the map CD-ROM removed from the display & NAVI control unit, drive the vehicle. After driving the vehicle, reinstall the map CD-ROM. Compare the saved driving tracks for the vehicle's current location with roads on the map.

Example

<The position marker consistently indicates the wrong position when driving in the same area. Determine if this is the result of the map matching function or the GPS function.>

→ Perform test pattern 1.

<To verify the accuracy of the road configuration shown on the display>

→ Perform test patterns 1 and 2.

- Compare the map and the saved driving tracks. The precision of the saved driving tracks is within several hundred meters.

<To make distance calibration and adjustments>

→ Perform test patterns 1 and 2.

- Make adjustments by driving the vehicle over a known course (highway or other road where distances are clearly marked). Calibrate the distance against the known distance. Use the formula below.

Calibration value = Screen display distance/Actual distance

GI

MA

EM

LC

EC

FE

AT

TF

PD

AX

SU

BR

ST

RS

BT

HA

SC

EL

IDX

NAVIGATION SYSTEM

Trouble diagnoses (Cont'd)

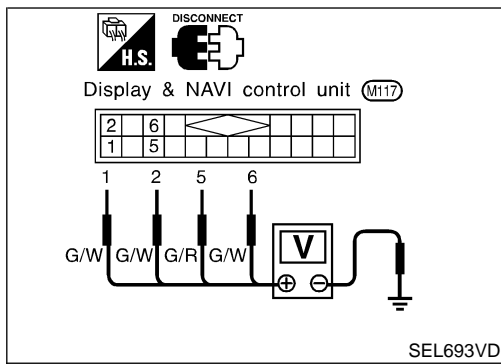

POWER SUPPLY AND GROUND CIRCUIT CHECK FOR DISPLAY & NAVI CONTROL UNIT

=NBEL0234S04

Power Supply Circuit Check

NBEL0234S0401

Terminal		Ignition switch		
(+)	(-)	OFF	ACC	ON
1	Ground	Battery voltage	Battery voltage	Battery voltage
2	Ground	Battery voltage	Battery voltage	Battery voltage
5	Ground	0V	0V	Battery voltage
6	Ground	0V	Battery voltage	Battery voltage

If NG, check the following.

- 7.5A fuse [No. 11, located in the fuse block (J/B)]
- 10A fuse [No. 10, located in the fuse block (J/B)]
- 15A fuse [No. 4, located in the fuse block (J/B)]
- Harness for open or short between fuse and display & NAVI control unit

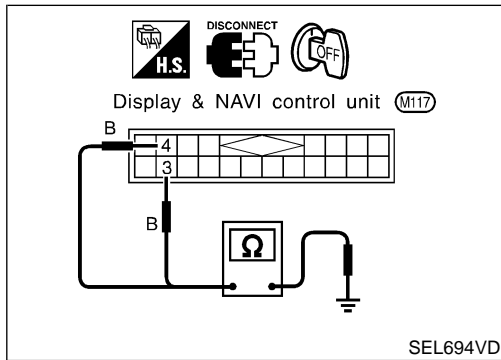

Ground Circuit Check

NBEL0234S0402

Terminals	Continuity
3 - Ground	Yes
4 - Ground	Yes

VOICE GUIDE OPERATION CHECK

=NBEL0234S05

1	PRELIMINARY CHECK	
1. Turn ignition switch to ACC position. 2. Insert the music CD into the radio and CD player. 3. Try to play the music CD. Is the sound emitted from all speakers? <p style="text-align: right;">Yes or No</p>		
Yes	▶	GO TO 2.
No	▶	Repair or replace audio system. Refer to "AUDIO" in EL-160.

GI
MA
EM
LC

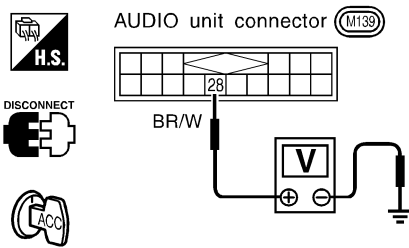
2	CHECK NAVI OPERATION ON SIGNAL	
1. Disconnect audio unit connector. 2. Push "VOICE" button. 3. Check voltage between terminal 28 and ground.		
		
Voltage [V]: Condition of VOICE button: Push. Approx. More than 0 - 10 Condition of VOICE button: Do not push. 0		
SEL645XA		
OK or NG		
OK	▶	GO TO 3.
NG	▶	Repair or replace harness or NAVI control unit.

EC
FE
AT
TF
PD
AX
SU

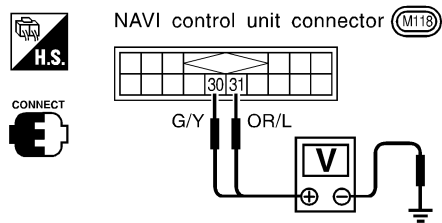
3	CHECK VOICE SIGNAL CIRCUIT	
1. Push "VOICE" button. 2. Check voltage between NAVI control unit terminal 30 or 31 and ground.		
		
Voltage [V]: Condition of VOICE button: Push. Approx. 5 Condition of VOICE button: Do not push. 0		
SEL648X		
OK or NG		
OK	▶	GO TO 4.
NG	▶	Repair or replace NAVI control unit.

BR
ST
RS
BT
HA
SC
EL
IDX

NAVIGATION SYSTEM

Trouble diagnoses (Cont'd)

4	CHECK VOICE SIGNAL CIRCUIT
<p>1. Turn ignition switch OFF. 2. Disconnect NAVI control unit connector and AUDIO unit connector. 3. Check continuity between NAVI control unit terminal 30 and AUDIO unit terminal 36. 4. Check continuity between NAVI control unit terminal 31 and AUDIO unit terminal 34.</p>	
SEL649X	
Yes or No	
Yes	▶ Repair or replace audio system. Refer to "AUDIO" in EL-160.
No	▶ Repair or replace harness or connector.

This Condition is Not Abnormal

=NBEL0235

NBEL0235S01

EXAMPLE OF BASIC OPERATIONAL ERRORS

Symptom	Possible cause	Repair order
No image is displayed.	Monitor brightness control is set to full dark.	Readjust monitor brightness.
Map does not appear on display.	Map CD is not inserted or inserted upside down.	Insert the map CD with the label facing up.
	Map mode is turned OFF.	Press the "MAP" button.
No guide tone is heard.	Voice guide adjustment OFF/Volume is set to the lowest or highest level.	Adjust the voice guide level.
Voice guide volume is too high or too low.		
Dark display/Slow image movement	Low vehicle interior temperature	Wait until vehicle interior temperature rises to appropriate level.
Small black or white dots appear on the screen.	Unique liquid crystal display phenomena	No problem
"Unable to read CD" message appears only during specified operation.	Map CD surface is tainted/CD surface is partially scratched.	Check map CD surface. If dirty, wipe clean with a soft cloth.
		If map CD surface is damaged, replace the CD.

Area place names are not displayed.

If area place names do not appear on the map display, these names may not be available. Use the BIRDVIEW[®] flat surface map display function. Display output may differ. Note the items related to BIRDVIEW[®] below.

- Priority is given to the display of place names in the direction of vehicle travel.
- Extended display of vehicle travel distance for both surfaces and steering angle (flat directional changes). This phenomenon disappears after the display image has been replaced by another one.
- The names of route and area might vary between the immediate front area and distance front area.
- Alphanumeric display characters are limited to maintain display simplicity and clarity. Display details may differ with time and place.
- Identical place and road names may appear on the display at more than one location.

GI

MA

EM

LC

EC

FE

AT

TF

PD

AX

SU

BR

ST

RS

BT

HA

SC

EL

IDX

NAVIGATION SYSTEM

This Condition is Not Abnormal (Cont'd)

EXAMPLE OF CURRENT VEHICLE POSITION MARKER ERROR

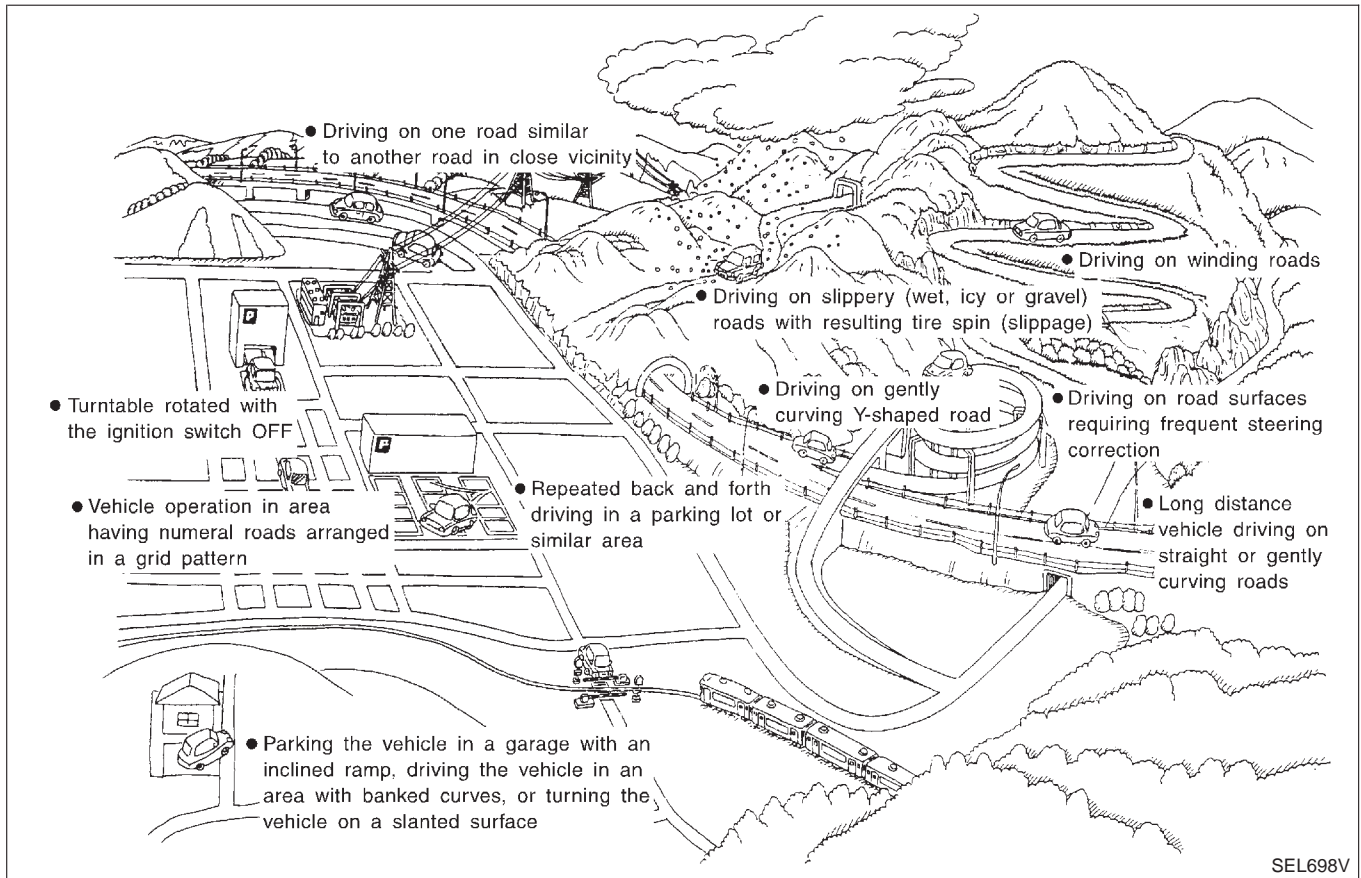

=NBEL0235S02

The navigation system reads the vehicle distance and steering angle data. Because the vehicle is moving, there will be an error in the current position indication. After the error appears, drive the vehicle for a short distance. Stop the vehicle. If the position marker does not return to its original position, perform "ADJUST CURRENT LOCATION" (EL-411).

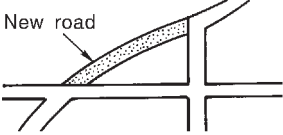

NAVIGATION SYSTEM

This Condition is Not Abnormal (Cont'd)

	Possible cause	Drive condition	Service procedure
Area	Slippery road surface	On wet, icy, or gravel road where frequent wheel slippage occurs, distance calculations may be erroneous. The position marker may show the vehicle to be in inaccurate position.	
	Slanted area	Hilly areas where the road has banked curves. When the vehicle enters these banked curves, there may be an error in steering angle measurement. The position marker may show the vehicle to be in inaccurate position.	
Map data	Map display for a given road does not appear.  SEL699V	When the vehicle is driven on a newly constructed road that does not appear on the existing map. Map marking and calibration are not possible. The position marker may indicate inaccurate position in close proximity to the actual position. Subsequently, when the vehicle is driven on a road which is available as map data, the position marker may still indicate an inaccurate position.	If the position marker does not move to the correct position even after the vehicle has been driven approximately 10 km (6 miles), perform "ADJUST CURRENT LOCATION" (EL-411). If necessary, perform "SPEED CALIBRATION" (EL-409).
	The vehicle is driven on a road whose course has been altered (usually to improve the road or to eliminate some hazard).  SEL700V	When the map data shown on the display and the actual conditions are different. Map matching will not be possible. The position marker may indicate inaccurate position in close proximity to the actual position. If the vehicle is driven on the indicated road, further errors may occur.	
Vehicle	Use of tire chains (Stormy weather)	Tire chains will affect distance sensing. The position marker may indicate inaccurate position.	If the position marker does not move to the correct position even after the vehicle has been driven approximately 10 km (6 miles), perform "SPEED CALIBRATION" (EL-409). After removing the tire chains, sensing accuracy may recover by itself.

GI
 MA
 EM
 LC
 EC
 FE
 AT
 TF
 PD
 AX
 SU
 BR
 ST
 RS
 BT
 HA
 SC
EL
 IDX

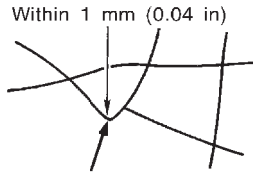
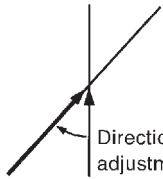

NAVIGATION SYSTEM

This Condition is Not Abnormal (Cont'd)

	Possible cause	Drive condition	Service procedure
Operation	Driving immediately after starting engine.	The gyro (angular velocity sensor) needs about 15 seconds after the engine is started to precisely sense the angular velocity. Directional sensing errors will occur if the vehicle is moved immediately after starting the engine. The position marker may indicate inaccurate position.	Wait a few moments between starting the engine and actually driving the vehicle.
	Continuous driving for long distances (non-stop)	When the vehicle is driven continuously without stopping over a long distance, errors in directional sensing may occur. The position marker may indicate inaccurate position.	Stop the vehicle. Perform "SPEED CALIBRATION" (EL-409).
	Rough or violent driving	Wheel spinning (peeling out) or similar rough driving techniques can adversely affect sensing accuracy. The position marker may indicate inaccurate position.	If the position marker does not move to the correct position even after the vehicle has been driven approximately 10 km (6 miles), perform "ADJUST CURRENT LOCATION" (EL-411).
Positional calibration procedures	Positional calibration precision  Within 1 mm (0.04 in) SEL701V	If current vehicle location is roughly set, the system may be unable to locate the road that the vehicle is traveling on. (This is especially true in an area where there are many roads.)	Perform "ADJUST CURRENT LOCATION" (EL-411) within a precision standard of 1 mm (0.04 in) on the display. Note: During calibration, use the most detailed map possible.
	Position calibration direction  Direction calibration adjustment SEL702V	When calibrating the position, check the vehicle direction. If the vehicle direction is not correct, subsequent precision of current location will be affected.	Perform "ADJUST CURRENT LOCATION", refer to EL-411.

NAVIGATION SYSTEM

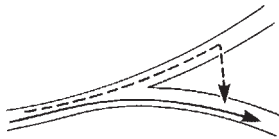
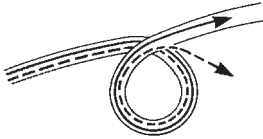
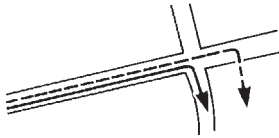
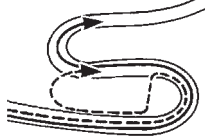
This Condition is Not Abnormal (Cont'd)

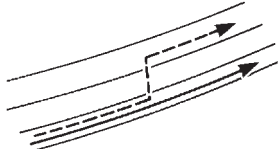
	Possible cause: —: Vehicle running ---: Indication	Drive condition	Service procedure	
Road shapes	<p>Y-intersection</p>  <p>SEL703V</p>	<p>In Y-intersections with a very gradual change in course, a directional sensing may be inaccurate. This may result in the position marker giving the wrong road indication.</p>		GI MA EM LC
	<p>Spiral road</p>  <p>SEL704V</p>	<p>On loop bridges and similar structures which result in a large and continuous turn, turning angle may be sensed inaccurately. As a result, the position marker may separate from the route on the map.</p>		EC FE AT
	<p>Straight road</p>  <p>SEL705V</p>	<p>In long distance driving on a straight road or road with very gradual curves, map marking inaccuracies may occur. In such cases, the position marker may stray from the route being traveled during subsequent turns due to inaccurate distance calculation.</p>	<p>If the position marker does not move to the correct position even after the vehicle has been driven approximately 10 km (6 miles), perform "Store place". If required, also perform "ADJUST CURRENT LOCATION" (EL-411).</p>	TF PD AX
	<p>Winding road</p>  <p>SEL706V</p>	<p>Directional sensing precision errors may occur when traveling on winding roads. During map matching, the position marker may stray to an adjacent road having a similar shape. Subsequent position marker error may occur.</p>		SU BR ST
	<p>Grid-like road shape</p>  <p>SEL707V</p>	<p>Directional sensing and distance sensing, precision errors may occur because of many roads having a similar shape in the immediate area. During map matching, the position marker may stray to an adjacent road having a similar shape. Subsequent position marker error may occur.</p>		RS BT HA
	<p>Parallel roads</p>  <p>SEL708V</p>	<p>When driving on a parallel road, map matching errors may occur. Subsequent position marker error may also occur.</p>		SC EL IDX

NAVIGATION SYSTEM

This Condition is Not Abnormal (Cont'd)

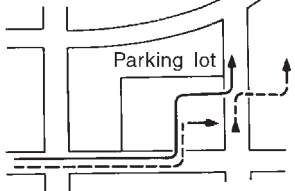
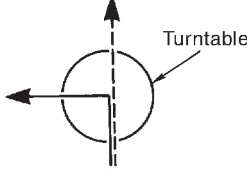
Possible cause: —: Vehicle running ---: Indication		Drive condition	Service procedure
Location	Parking lot or similar area  SEL709V	When the vehicle is driven in a parking lot or similar area, such as in an area not normally marked as a road on map, during map matching, the system may select nearby roads. This error may continue after the vehicle exits the parking area and begins to run on ordinary roads. Vehicle operation in a parking area may involve frequent turns and up and/or down operation. Directional sensing errors may occur leading to subsequent route and position mistakes.	
	Turntable  SEL710V	When the ignition switch is OFF (the usual situation when the vehicle is on a turntable), the navigation system receives no data from the gyro (angular velocity sensor). When the turntable rotates, no directional change is sensed. During subsequent vehicle operation, directional and route errors may occur.	

Position marker displays a completely different location

In circumstances such as those described below, GPS signal reception conditions may result in an erroneous position of the position marker. Perform "ADJUST CURRENT LOCATION" (EL-411).

NOTE:

- When GPS satellite signal reception conditions are poor, the position of position marker may be erroneous. If correction is not made immediately, the position marker error will be compounded and a completely different location will be indicated. In an area where GPS satellite signal reception conditions are good, the system can be returned to normal operation.
- The vehicle is driven aboard a car ferry or is towed for some distance with the ignition switch OFF. Vehicle movement is not sensed. Current location calculations do not occur and current location data does not appear on the display screen. Use GPS to accurately determine actual vehicle position. The system can be returned to normal operation when the GPS satellite signal reception conditions are good.

Position marker jumps

In circumstances such as those described below, the position marker may jump as a result of automatic current location corrections made by the system.

During map matching

- During map matching, the position marker may jump from one spot to another. In this case, it may be corrected to a wrong road or to an area where no road exist.

GPS location correcting

- Vehicle current location is sensed using the GPS data. Positional calibration is performed. The position marker continues to be in the wrong position. It may jump about from one area of the screen to another. In this case, it may be corrected to a wrong road or to an area where no road exist.

Position marker indicates that the vehicle is in the middle of an ocean or large river

The navigation system does not distinguish between land and water surfaces. In some cases, a position marker error may cause the display to show the vehicle above a water surface.

Position of position marker varies when the vehicle is repeatedly operated on the same road

Driving lane and steering wheel movement results in a variety of different positions of the position mark when traveling on the same road based on sensing results by the GPS antenna and gyro (angular velocity sensor).

Slow locational correction using map matching

- The map matching function requires verification of local data. To make the map matching function, some distance needs to be driven.
- The map matching function may not provide accurate performance in an area where there are numerous parallel roads. Until the system judges the road characteristics, an incorrect position may be shown.

GPS signal reception conditions are good. However, the position mark does not return to its proper position.

- The system senses the vehicle location with an error of approximately 100 m (328 ft). Due to the limitation of precision, the position marker may be inaccurate even if the GPS signal reception condition is good. GI
- The navigation system uses GPS data to determine vehicle location. GPS data is compared with other locational sensing data during the map matching process. The system decides which data is more precise and uses that data. MA
- When the vehicle is stationary, GPS data cannot be used to make system corrections. EM

Area designations on the map display and the BIRDVIEW® display differ.

To prevent the display from becoming congested, alphanumeric information is abridged.

[No problem] LC

Correct position of your vehicle is not displayed.

Vehicle position changed after ignition key was turned to the OFF position (Vehicle is transported on car ferry, car train, or by some other means). EC

[Operate vehicle for short time under GPS receiving conditions.]

The display does not change to night-time mode even though the light switch has been turned ON.

Lights have been turned on. In "DISPLAY CHANGE" mode, night-time mode on display has been switched to day-time mode and still is. FE

[Turn lights on again. Set the display to night-time mode. Refer to EL-412.]

Map does not scroll even though the position of your vehicle is changed.

Present area does not appear on the display. AT

[Press the "MAP" switch.]

Vehicle position marker does not appear.

Present area does not appear on the display. TF

[Press the "MAP" switch.]

The map surface precision display (GPS satellite marker) still remains gray.

Vehicle is parked inside a building or in the shadow of a large building. This intercepts the GPS signal. PD

[Move the vehicle to a more open position.]

GPS signal is not received because objects are placed on the rear parcel shelf. AX

[Remove objects from the rear parcel shelf.]

GPS satellite position is bad.

[Wait until GPS satellite position improves.] SU

Vehicle position precision is bad.

The map surface precision display (GPS satellite marker) still remains gray.

[Refer to "The map surface precision display (GPS satellite marker) still remains gray" item (Symptoms)] BR

Vehicle speed and elapsed distance is calculated from the vehicle speed pulse. This pulse is dependent upon tire size. If tire chains are used on the vehicle, accuracy will be affected (pulse rate will be too fast or too slow). The same is true if the system installed to your vehicle is removed and installed on another vehicle. ST

[Drive the vehicle at a speed higher than 30 km/h (19 MPH) for approximately 30 minutes. Automatic readjustment should occur. If it does not (remains too fast or too slow), distance calibration is required. Or, drive the vehicle for a short distance. Perform "SPEED CALIBRATION" (EL-409). After removing the tire chains, sensing accuracy may recover by itself.] RS

Bad map data or system defect (same error consistently occurs in the same area) BT

ROUTE SEARCH/ROUTE GUIDE

- If the present location or the destination location is displayed in the avoid area, it is not possible to search routes. HA
- If the avoid area is set to wide range area, it may not be possible to find appropriate routes or search for alternate routes. SC
- The automatic re-route calculates a return to the original route. Because of this, it may not be possible to search appropriate new routes. If you deviate from the original route and wish to select an appropriate new route, touch "Route Calculation".
- The automatic re-route function may sometimes require considerable time.
- Displayed route number and directional information at a highway junction may differ from the information posted on the actual road signs.
- Displayed street name information at a highway exit may differ from the information posted on the actual road signs.
- Street name information displayed on the enlarged intersection map may differ from the information posted on the actual road signs.

EL

IDX

NAVIGATION SYSTEM

This Condition is Not Abnormal (Cont'd)

- The enlarged intersection map may display an “Unknown Street” message at some street intersections.
- Because of road configuration, etc. the guide may finish early. If this occurs, follow the marker to reach your destination.
- Destination area side information (left side and right side) may differ from actual conditions because of data error.

Unable to Set Destination, Way Point, and/or Menu Items

NBEL0235S0301

Symptom	Possible cause	Repair order
Unable to search way points in re-search mode	A way point already crossed or determined to have been crossed.	If you desire to pass through a way point for a second time, reperform route edit.
Turn list is not displayed.	Route search does not occur.	Set designation areas and perform route search.
	Car marker does not appear on recommended route.	Drive on the recommended route.
	Route guide is canceled.	Turn the route guide ON. (Push “VOICE” switch.)
Automatic search does not function.	Vehicle is not running on search object route (road indicated by orange, brown or red line).	Drive the vehicle on the search object route or perform a manual route search. Note that all routes will be re-searched at this time.
Unable to select detour route.	Vehicle is not running on recommended route.	Use the “RE-ROUTE” mode to search again or return to the recommended route.
Detour route search results are identical to previous search.	All possible conditions were considered, but results are the same.	This is not abnormal.
Unable to set a way point.	More than five way points have been previously set (and not cleared).	More than five way points cannot be specified at the same time. Break down into smaller segments and perform search.
Unable to select starting point during route edit.	Starting point will normally be your present location during route edit.	This is not abnormal.
Cannot select certain menu items.	While vehicle is running.	Park the vehicle in a safe area and perform operation.

Voice Guide Information

NBEL0235S0302

Symptom	Possible cause	Repair order
Voice guide does not function.	Voice guide is only available at certain intersections (marked with ♯). In some cases, the guide is not available even when the vehicle makes a turn.	This is not abnormal.
	Vehicle is not running on recommended route.	Return to recommended route or reperform route search.
	Voice guide is OFF.	Set voice guide to the ON position.
	Route guide is canceled.	Turn the route guide ON. (Push “VOICE” switch.)
The guide content does not correspond to actual conditions.	The content of the voice guide may vary depending on the type of junction.	Operate vehicle following the traffic rules and regulation.

Route Search Information

NBEL0235S0303

Symptom	Possible cause	Repair order
Proceeding in desired direction. However, route search in desired direction does not function.	Unable to find appropriate route in the desired direction.	This is not abnormal.

NAVIGATION SYSTEM

This Condition is Not Abnormal (Cont'd)

Symptom	Possible cause	Repair order	
No route is displayed.	No object route is searched near destination area.	Adjust position to wide road (brown) near destination area. In an area where traffic direction is displayed separately, pay close attention to the direction of travel. Set the destination area and the way point over the road.	GI MA
	Starting point and destination areas are very near.	Move destination areas away from starting point on the screen.	EM
Recommended route which has been passed disappears from the display.	The recommended route is divided into individual control segments. When way point 1 is passed, the data from the starting point to the way point 1 is erased.	This is not abnormal.	LC
Search recommends roundabout route.	There may be special conditions for roads near the starting point and destination area (one-way traffic, etc.). A roundabout route may be displayed.	Slightly change starting point and destination area settings.	EC FE
Landmark display does not show actual conditions.	Mistaken or missing map data may result in erroneous display.	Change map CD.	AT
Recommended route drawn slightly away from starting point, way points, and destination area.	Course search data may not exist for closely positioned starting point, way points, and destination area shown on the map. Route guide starting point, way point, and destination point may be separated.	Set the destination area to the general route (indicated by a thick brown line). However, even if the selected route is a major one, appropriate route search data may not be available.	TF PD

LOCATION OF CAR MARKER

NBEL0235S04

- If the vehicle has been parked in a multi-level parking facility or underground parking facility, the car marker position may be inaccurate immediately after exiting the parking facility.
- The GPS accuracy is within ± 100 m (300 ft). Even when receiving conditions are excellent, further positional correction may not occur.

STREET INDICATION

NBEL0235S05

- Street names displayed on the map may differ from the actual street names.
- An "Unknown Street" message may appear on the map in place of street name information.

RESEARCH

NBEL0235S06

- Position may be searched by house number. However, the displayed position and street may differ from the actual position and street.
- When position is searched using POI, the displayed position may differ from the actual position.
- Some data may not be available for new buildings and other structures in a map.

GPS ANTENNA

NBEL0235S07

- Do not place metal objects above the GPS antenna mounted on the rear parcel shelf. This will cause interference with signal reception.
- Do not place mobile telephones or vehicle radio transceivers in close proximity to the GPS antenna mounted on the rear parcel shelf. This may cause interference with signal reception.

GI

MA

EM

LC

EC

FE

AT

TF

PD

AX

SU

BR

ST

RS

BT

HA

SC

EL

IDX

Program Loading

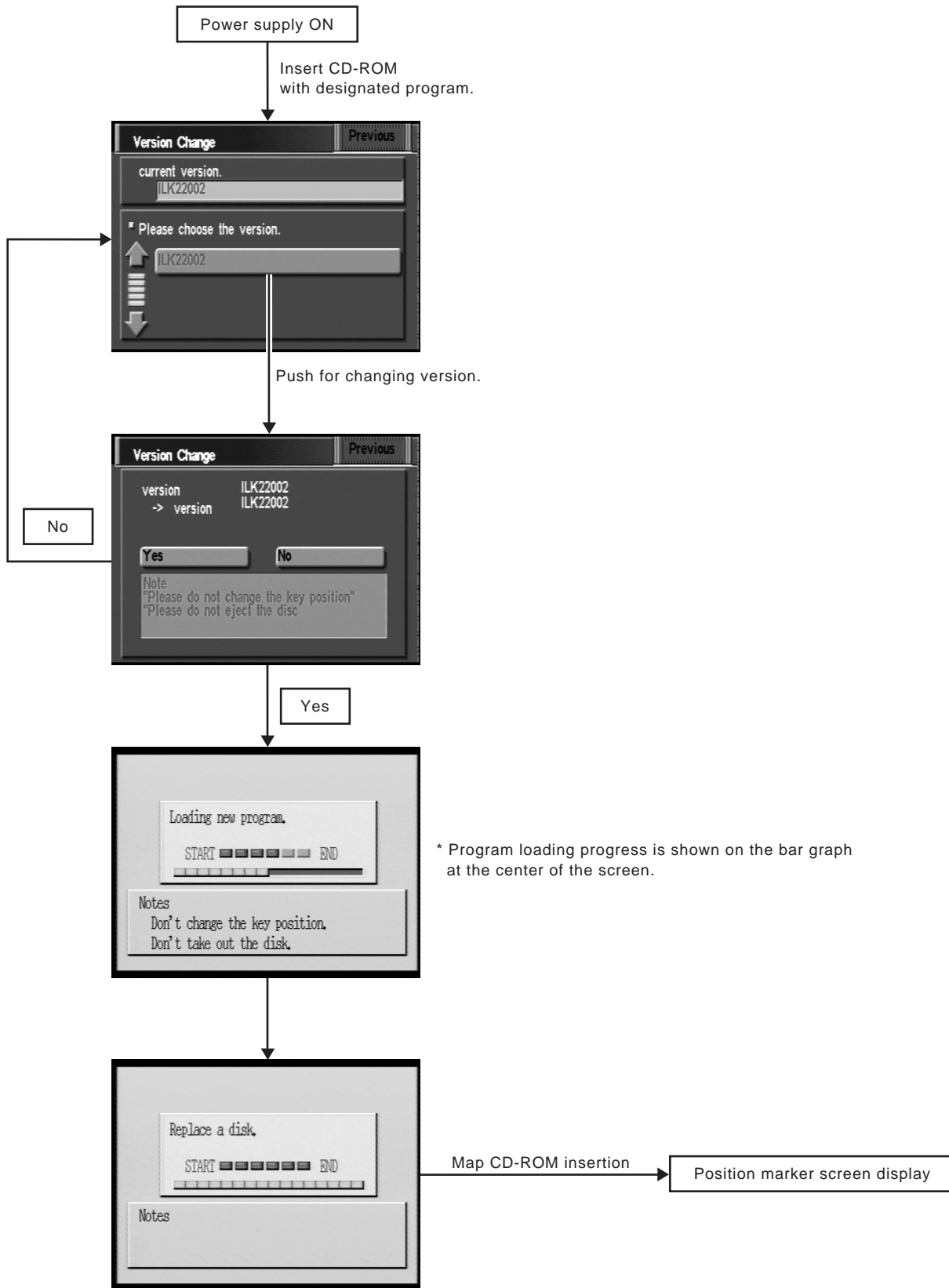

Note: Load the program only after the engine has been started.

Initialization

This procedure is for initializing the current location. Perform "Initialize Location" when the vehicle is transported a long distance by trailer, etc.

Map with grey background appears and the vehicle location cannot be adjusted by scrolling the display when the vehicle location in the memory is out of the area of the inserted map data.

Perform "Initialize Location" when this occurs.

NOTE:

- Only initialize the system when the display & NAVI control unit is replaced. If the system is initialized in other cases, it may cause inaccurate positioning of the position marker for a while.
- Initialize the system outside for receiving the radio wave from the GPS satellite.

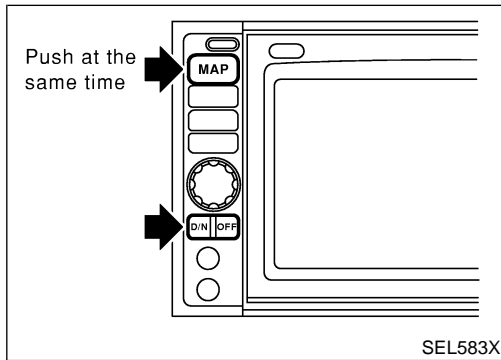

HOW TO PERFORM

1. Switch the navigation system mode to self-diagnosis by pushing both "MAP" and "D/N" switches at the same time for more than 5 seconds.

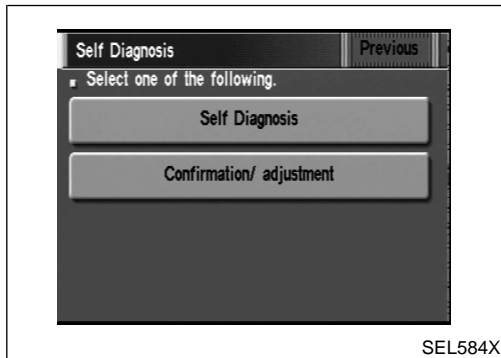

2. Touch "Confirmation/ adjustment".

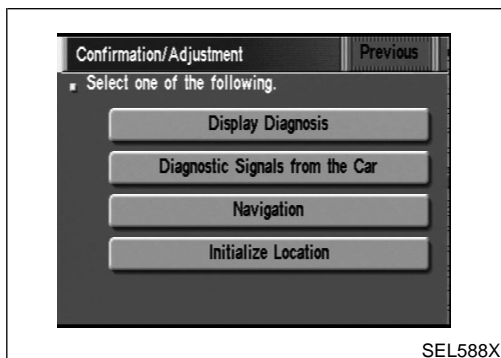

3. Touch "Initialize Location". Then the previous screen is displayed.

NAVIGATION SYSTEM

Initialization (Cont'd)

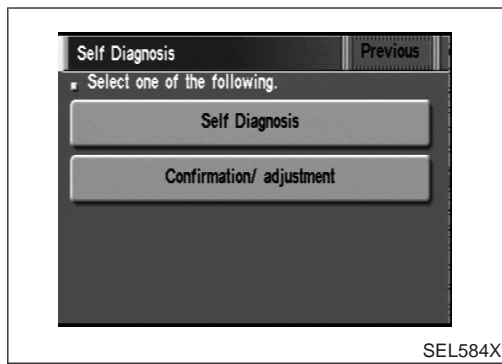

4. Push "Previous" switch.

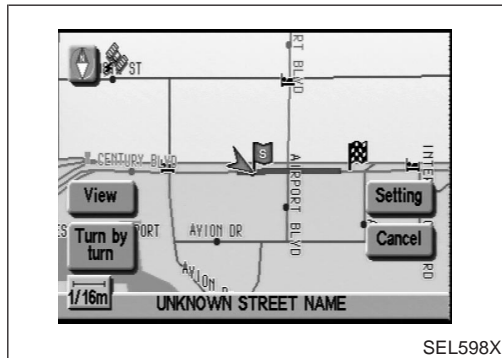

5. Push the "MAP" switch.

6. Touch "Setting".

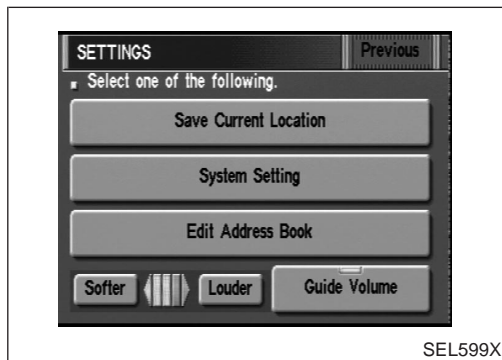

7. Touch "System Setting".

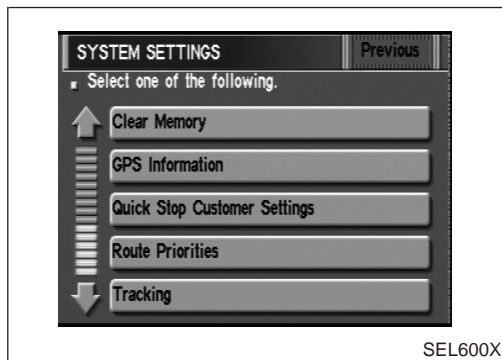

8. Touch "GPS Information".

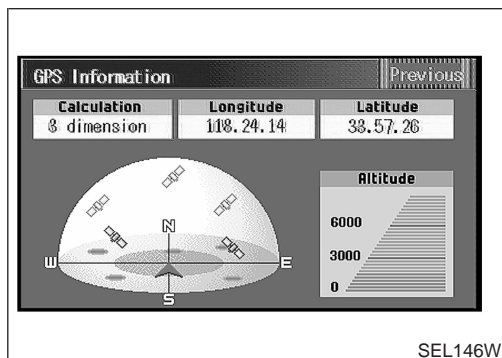

9. More than one GPS satellite icon turns green. (It may take 1 to 15 minutes.)

NOTE:

Drive the vehicle for a while* in order to change the receiving condition of the radio wave from the GPS satellite if the GPS icon does not turn green.

* The driving distance which is necessary depends on the receiving condition of the radio wave from the GPS satellite.

NAVIGATION SYSTEM

Initialization (Cont'd)

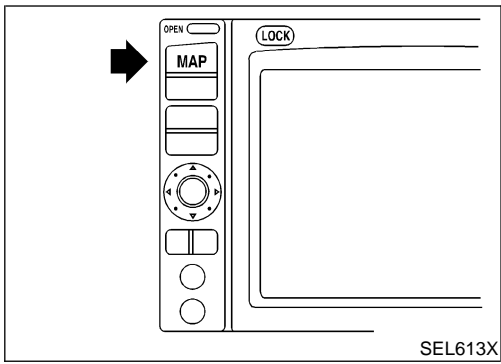

10. Push "MAP" switch and check the following.

- Confirm that the GPS icon on the map turns green.
- Then the position marker should show the current location.
- Position marker rotates corresponding to the movement of the vehicle.

11. Initialization is completed.

GI

MA

EM

LC

EC

FE

AT

TF

PD

AX

SU

BR

ST

RS

BT

HA

SC

EL

IDX

ELECTRICAL UNITS LOCATION

Engine Compartment

Engine Compartment

NBEL0129

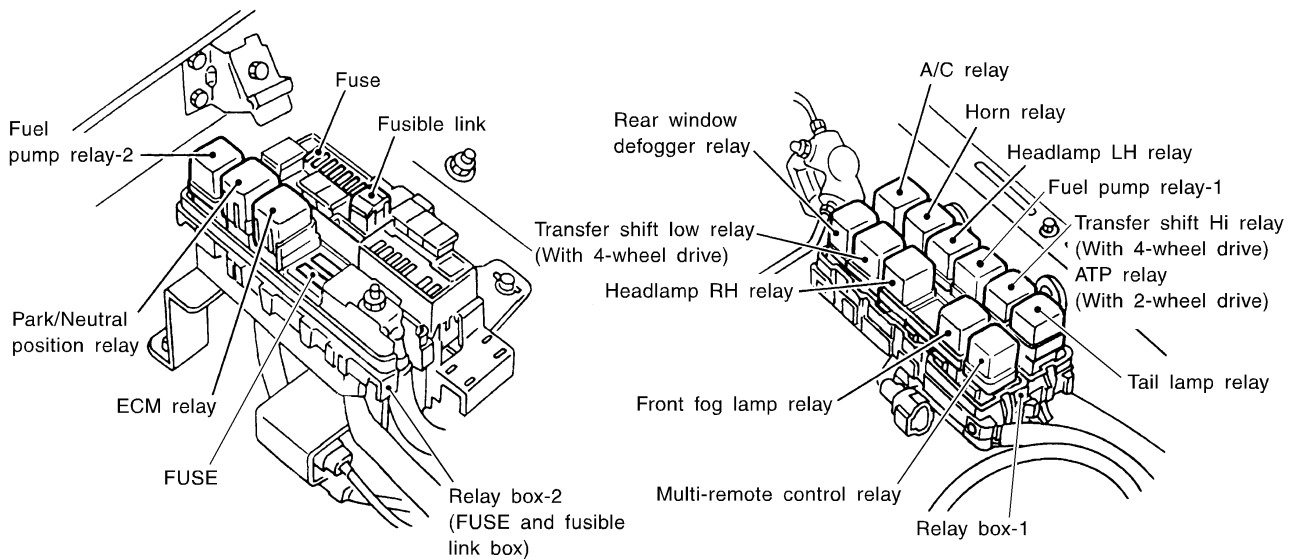
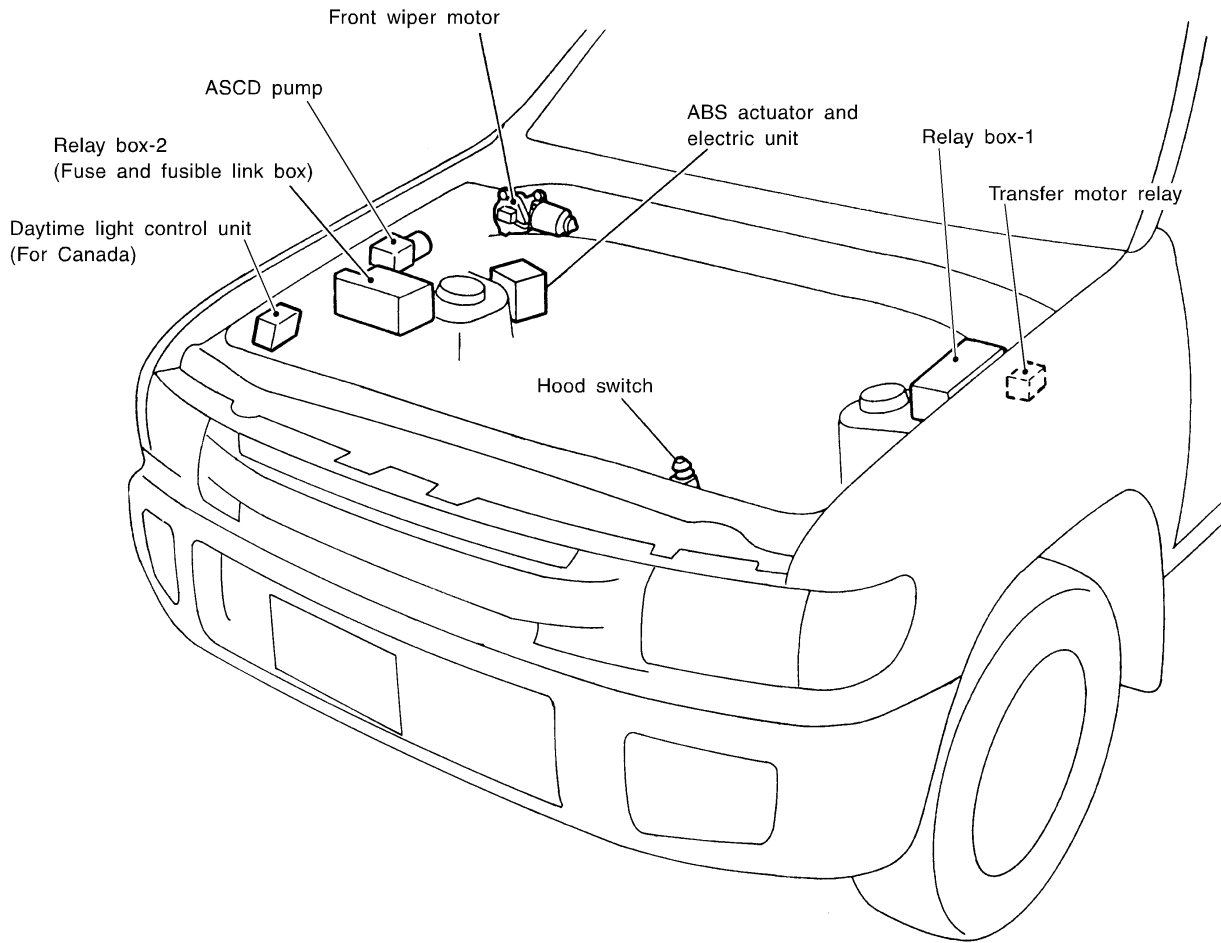

MEL134M

ELECTRICAL UNITS LOCATION

Engine Compartment (Cont'd)

NOTE:

GI

MA

EM

LC

EC

FE

AT

TF

PD

AX

SU

BR

ST

RS

BT

HA

SC

EL

IDX

ELECTRICAL UNITS LOCATION

Passenger Compartment

Passenger Compartment

NBEL0130

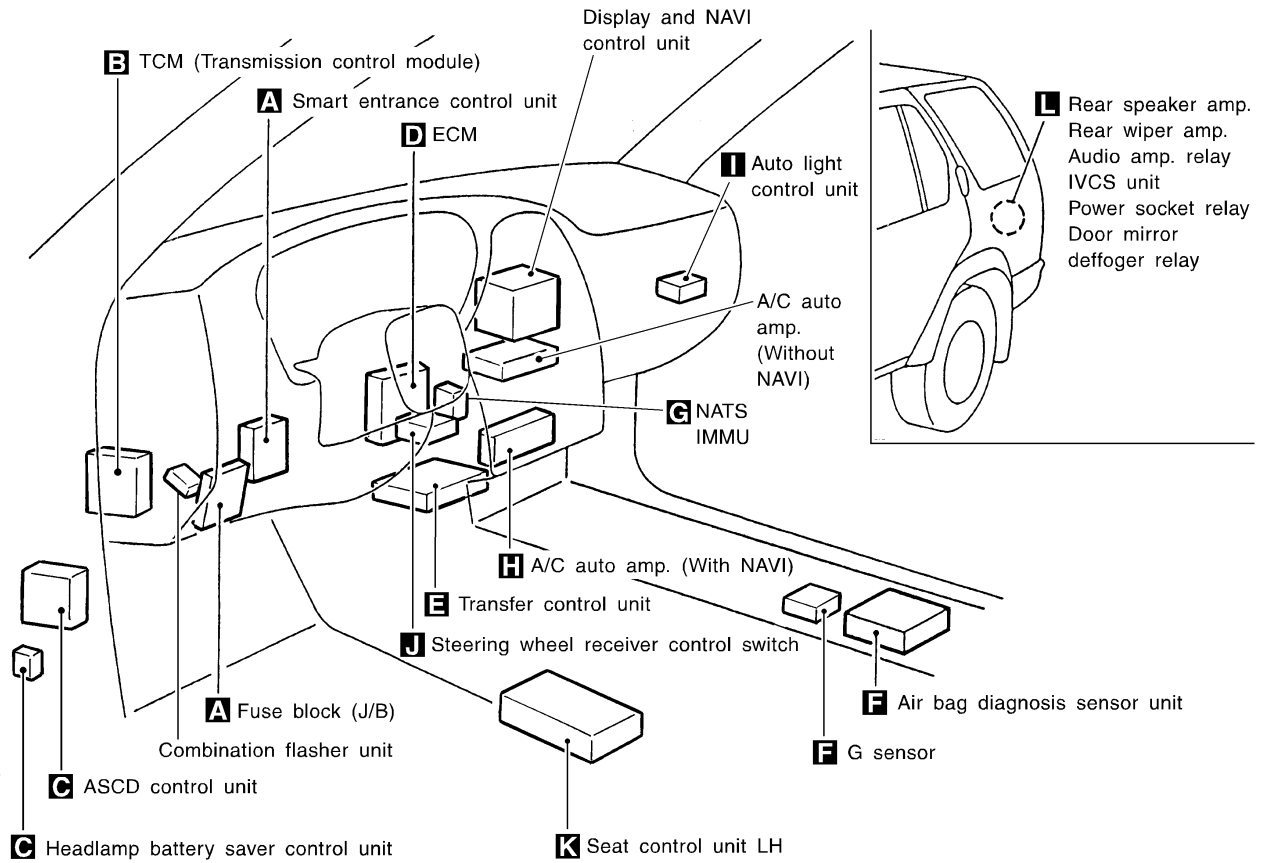

A Instrument panel LH side

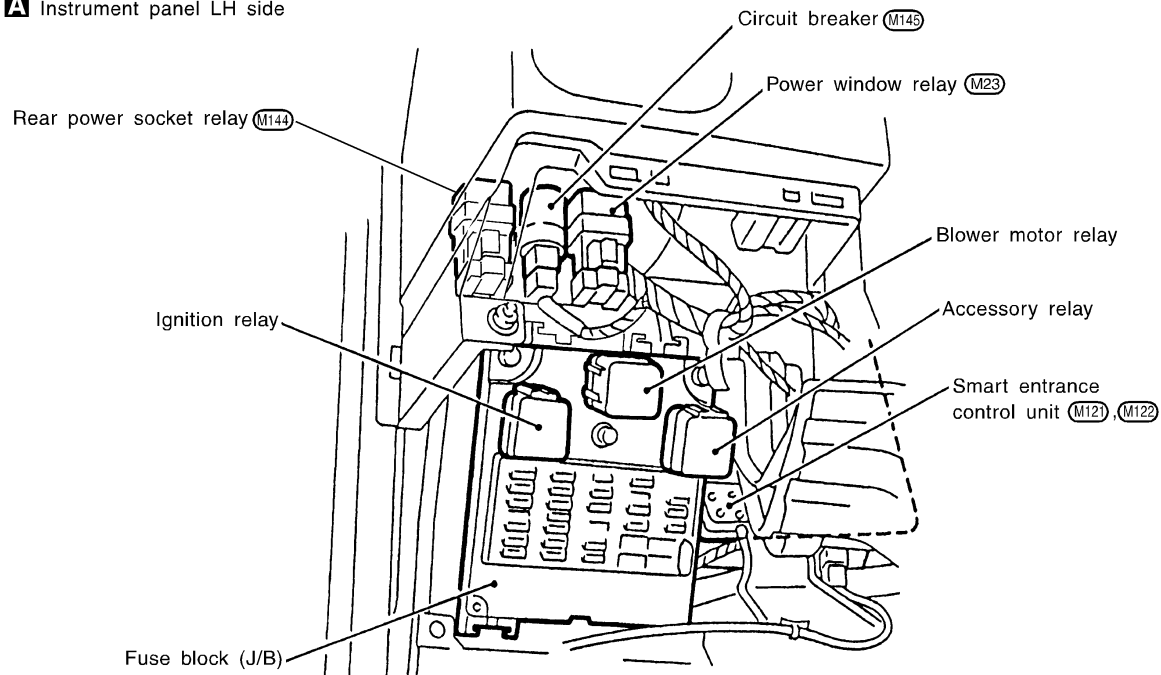

MEL135M

ELECTRICAL UNITS LOCATION

Passenger Compartment (Cont'd)

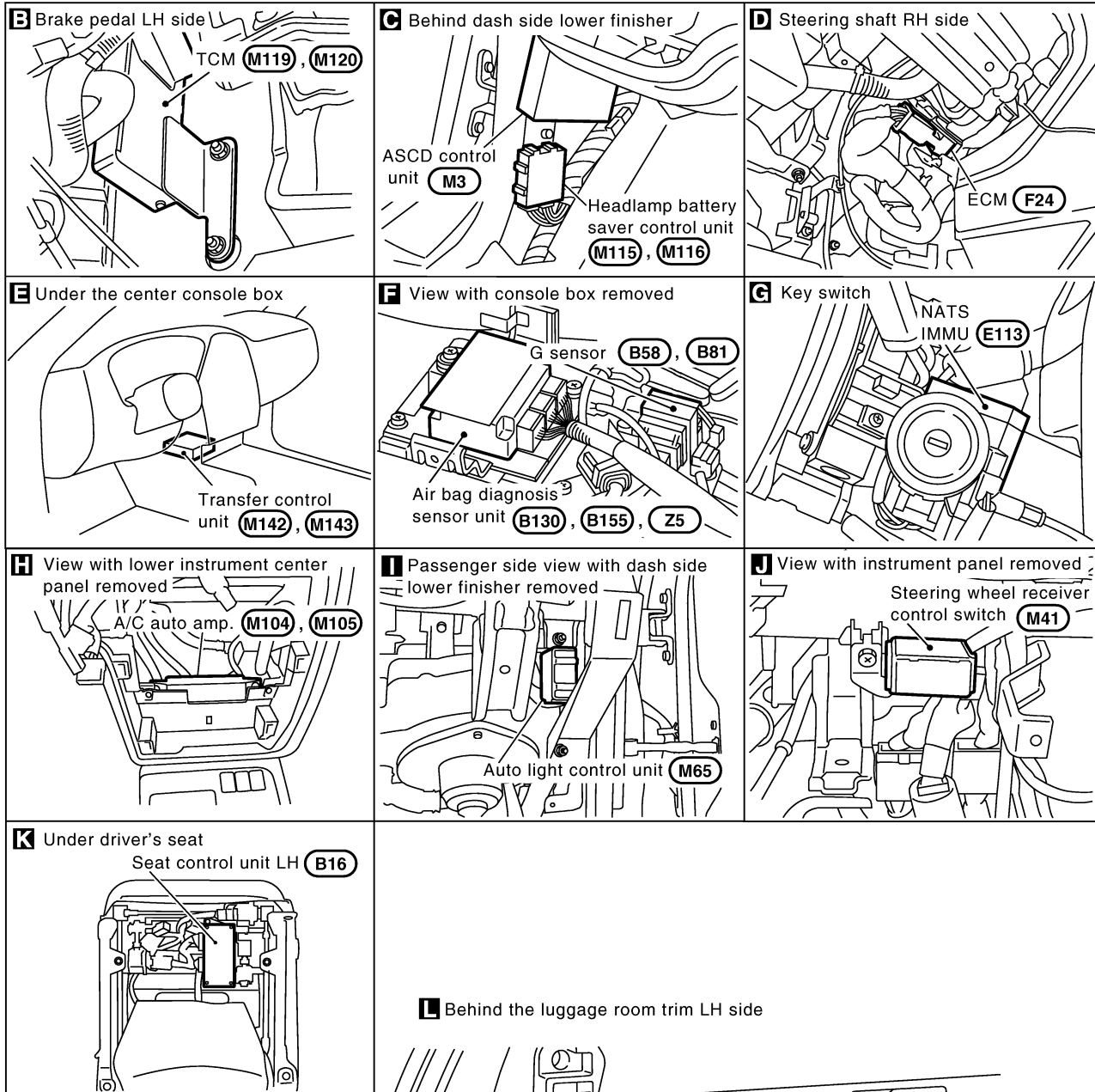

L Behind the luggage room trim LH side

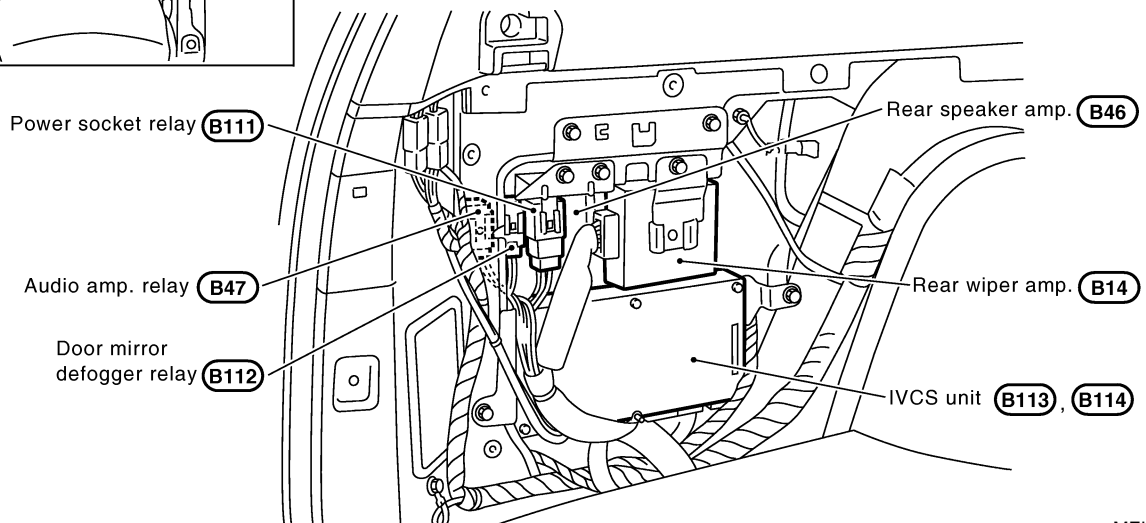

GI
MA
EM
LC
EC
FE
AT
TF
PD
AX
SU
BR
ST
RS
BT
HA
SC
EL
IDX

MEL136M

HARNESS LAYOUT

How to Read Harness Layout

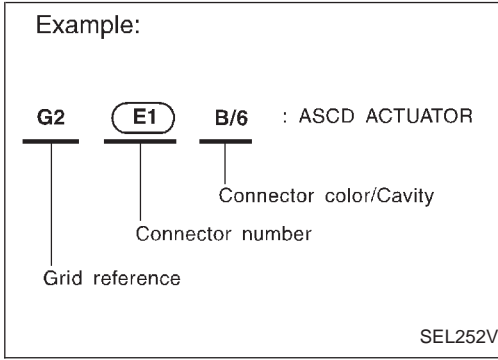

The following Harness Layouts use a map style grid to help locate connectors on the drawings:

- Main Harness
- Engine Room Harness (Engine Compartment)
- Engine Control Harness

TO USE THE GRID REFERENCE

1. Find the desired connector number on the connector list.
2. Find the grid reference.
3. On the drawing, find the crossing of the grid reference letter column and number row.
4. Find the connector number in the crossing zone.
5. Follow the line (if used) to the connector.

CONNECTOR SYMBOL

Main symbols of connector (in Harness Layout) are indicated in the below.

Connector type	Water proof type		Standard type	
	Male	Female	Male	Female
<ul style="list-style-type: none"> • Cavity: Less than 4 • Relay connector 				
<ul style="list-style-type: none"> • Cavity: From 5 to 8 				
<ul style="list-style-type: none"> • Cavity: More than 9 	—	—		
<ul style="list-style-type: none"> • Ground terminal etc. 	—			

HARNESS LAYOUT

Outline

Outline

NBEL0132

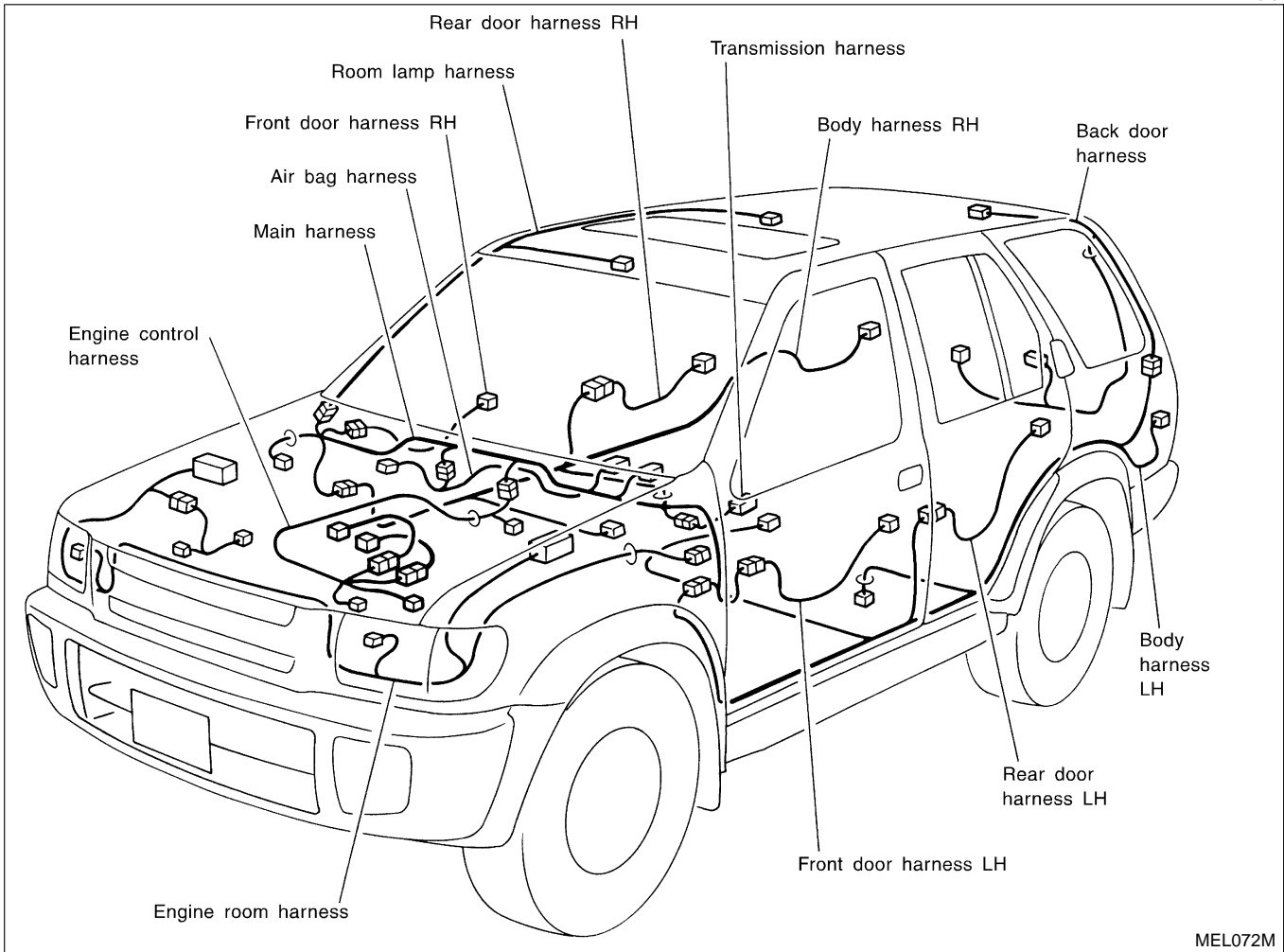

MEL072M

GI

MA

EM

LC

EC

FE

AT

TF

PD

AX

SU

BR

ST

RS

BT

HA

SC

EL

IDX

HARNESS LAYOUT

Engine Room Harness

Engine Room Harness

NBEL0134

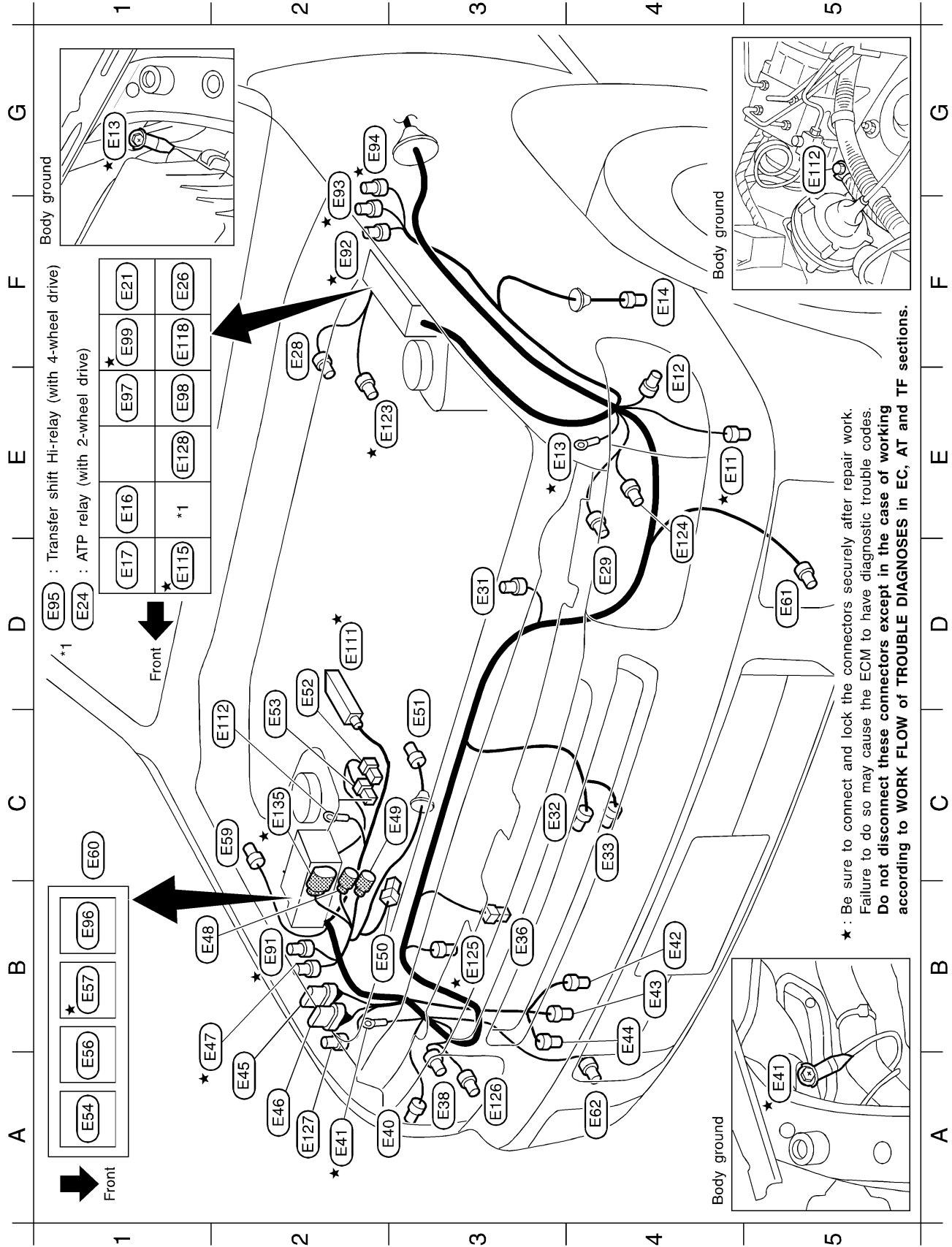

MEL075M

HARNESS LAYOUT

Engine Room Harness (Cont'd)

★ : Be sure to connect and lock the connectors securely after repair work.
 Failure to do so may cause the ECM to have diagnostic trouble codes.
Do not disconnect these connectors except in the case of working
 according to **WORK FLOW of TROUBLE DIAGNOSES** in EC, AT and TF sections.

- B4 (E42) BR/2 : Washer level switch
- B4 (E43) GY/2 : Rear washer motor
- B4 (E44) GY/2 : Front washer motor
- A2 (E45) GY/8 : Daytime light control unit
- A2 (E46) GY/6 : Daytime light control unit
- B1★ (E47) GY/2 : AT dropping resistor
- B1 (E48) GY/4 : To (E102)
- C2 (E49) GY/1 : To (E104)
- B2 (E50) B/1 : Horn (High)
- C3 (E51) GY/2 : Front wheel sensor RH
- D2 (E52) B/1 : Battery
- D2 (E53) B/1 : Battery
- A1 (E54) L/4 : Fuel pump relay-2
- B1 (E56) GY/6 : Park/Neutral position relay
- B1★ (E57) BR/6 : ECM relay
- C2 (E59) GY/4 : ASCD pump
- C1 (E60) — : Fuse and fusible link box
- D5 (E61) B/3 : Front fog lamp LH
- A4 (E62) B/3 : Front fog lamp RH
- E63 (E63) W/3 : Combination switch (Front fog lamp switch)
- B2★ (E91) GY/2 : Transfer dropping resistor
- F2★ (E92) W/1 : Transfer motor relay
- G2★ (E93) W/1 : Transfer motor relay
- G2★ (E94) G/2 : Transfer motor relay
- E1★ (E95) B/5 : Transfer shift Hi relay (With 4-wheel drive) (Relay box-1)
- B1 (E96) — : Fuse block (Relay box-2)
- E1 (E97) BR/6 : Headlamp RH relay
- E1 (E98) BR/6 : Headlamp LH relay
- F1★ (E99) B/5 : Transfer shift low relay
- D2★ (E111) SMJ : ABS actuator and electric unit
- C2 (E112) — : Body ground
- (E113) W/8 : NATS IMMU
- (E114) W/4 : Combination switch (Rear wiper switch)
- D1 (E115) L/4 : Tail lamp relay (Relay box-1)
- ★ (E116) W/18 : To (M114)
- F1 (E118) BR/6 : Horn relay
- (E121) W/2 : Diode
- E2★ (E123) SB/2 : Swirl control valve control vacuum check switch
- E4 (E124) B/3 : Headlamp aiming motor LH

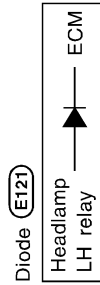

(Relay box-2)

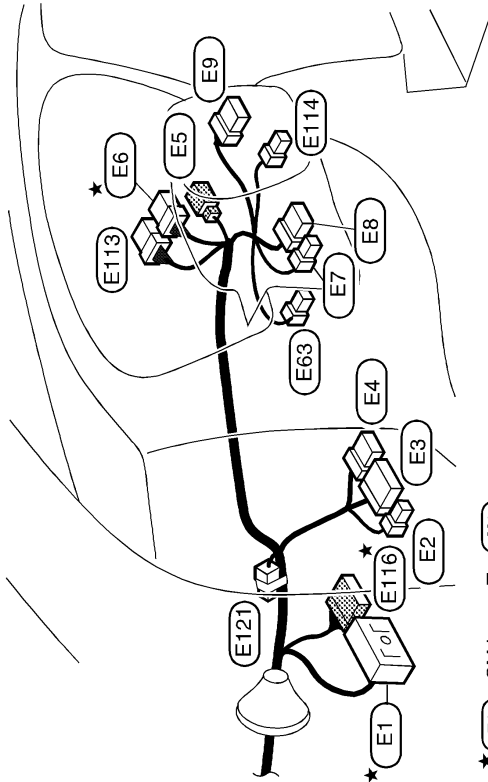

- ★ (E1) SMJ : To (M1)
- (E2) B/2 : Fuse block (J/B)
- (E3) W/16 : Fuse block (J/B)
- (E4) W/4 : Fuse block (J/B)
- (E5) BR/2 : Key switch
- ★ (E6) W/6 : Ignition switch
- (E7) BR/4 : Combination switch (Lighting switch)
- (E8) W/8 : Combination switch (Lighting & turn signal switch)
- (E9) GY/8 : Combination switch (Front wiper switch)
- E4★ (E11) GY/2 : Intake air temperature sensor
- E4 (E12) B/2 : Parking lamp LH
- E3★ (E13) — : Body ground
- F4 (E14) BR/2 : Front wheel sensor LH
- E1 (E16) L/4 : Front fog lamp relay
- D1 (E17) BR/6 : Multi-remote control relay
- F1 (E21) BR/6 : Rear window defogger relay
- E1 (E24) B/5 : ATP relay (With 2-wheel drive)
- F1 (E26) L/4 : A/C relay
- F2 (E28) GY/2 : Brake fluid level switch
- D4 (E29) B/4 : Headlamp LH
- D3 (E31) GY/2 : Hood switch
- C3 (E32) B/2 : Ambient sensor
- C4 (E33) B/2 : Ambient air temperature sensor (For thermometer)
- B3 (E36) B/1 : Horn (Low)
- A3 (E38) B/4 : Headlamp RH
- A2 (E40) B/2 : Parking lamp RH
- A2★ (E41) — : Body ground

GI
 MA
 EM
 LC
 EC
 FE
 AT
 TF
 PD
 AX
 SU
 BR
 ST
 RS
 BT
 HA
 SC
EL
 IDX

MEL076M

HARNESS LAYOUT

Engine Control Harness

Engine Control Harness

NBEL0135

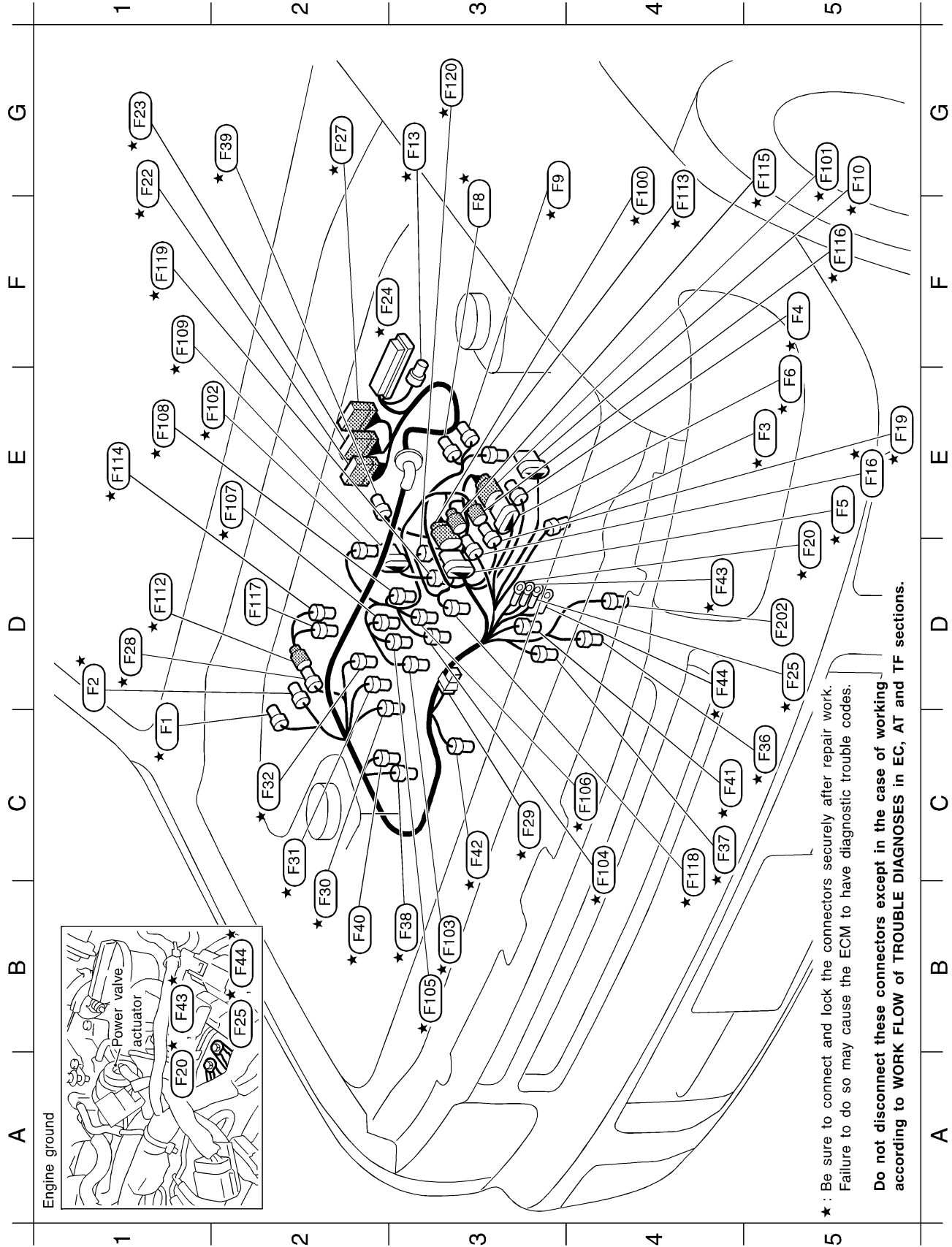

★ : Be sure to connect and lock the connectors securely after repair work.
Failure to do so may cause the ECM to have diagnostic trouble codes.

Do not disconnect these connectors except in the case of working according to WORK FLOW of TROUBLE DIAGNOSES in EC, AT and TF sections.

MEL077M

HARNES LAYOUT

Engine Control Harness (Cont'd)

C1★	(F1)	B/4	: Heated oxygen sensor 2 (Rear) (B1)	E2★	(F102)	GY/2	: Knock sensor
D1★	(F2)	GY/3	: Heated oxygen sensor 1 (Front) (B1)	B3★	(F103)	GY/2	: Injector No. 1
E5★	(F3)	GY/4	: Heated oxygen sensor 2 (Rear) (B2)	C4★	(F104)	GY/2	: Injector No. 2
F5★	(F4)	GY/3	: Heated oxygen sensor 1 (Front) (B2)	B3★	(F105)	GY/2	: Injector No. 3
E5★	(F5)	L/8	: To (F100)	C4★	(F106)	GY/2	: Injector No. 4
E5★	(F6)	G/8	: To (F101)	E2★	(F107)	GY/2	: Injector No. 5
F3★	(F8)	BR/3	: Throttle position sensor	E1★	(F108)	GY/2	: Injector No. 6
G3★	(F9)	GY/3	: Throttle position switch	F1★	(F109)	L/6	: IACV-AAC valve
G5★	(F10)	GY/5	: Mass air flow sensor	D1★	(F112)	SB/3	: To (F28)
G3★	(F13)	GY/3	: Absolute pressure sensor	F4★	(F113)	L/2	: EVAP canister purge volume control solenoid valve
E5★	(F16)	LGY/2	: To (F115)	E1★	(F114)	GY/2	: Engine coolant temperature sensor
E5★	(F19)	SB/2	: To (F116)	G5★	(F115)	LGY/2	: To (F16)
D5★	(F20)	—	: Engine ground	F5★	(F116)	SB/2	: To (F19)
G1★	(F22)	GY/16	: To (M33)	D2	(F117)	B/1	: Thermal transmitter
G1★	(F23)	BR/24	: To (M32)	C4★	(F118)	GY/3	: Ignition coil No. 2
F2★	(F24)	SMJ	: ECM	F1★	(F119)	GY/3	: Ignition coil No. 4
D5★	(F25)	—	: Engine ground	G3★	(F120)	GY/3	: Ignition coil No. 6
G2★	(F27)	W/18	: To (M94)	D5	(F202)	B/1	: Compressor (Air conditioner)
D1★	(F28)	SB/3	: To (F112)				
C3★	(F29)	W/2	: Condenser				
B2★	(F30)	GY/3	: Ignition coil No. 1				
C2★	(F31)	GY/3	: Ignition coil No. 3				
C2★	(F32)	GY/3	: Ignition coil No. 5				
C5★	(F36)	GY/2	: Camshaft position sensor (PHASE)				
C4★	(F37)	B/3	: Intake valve timing control position sensor LH				
B3★	(F38)	B/3	: Intake valve timing control position sensor RH				
G2★	(F39)	G/2	: Intake valve timing control solenoid valve LH				
B2★	(F40)	SB/2	: Intake valve timing control solenoid valve RH				
C4★	(F41)	G/2	: Swirl control valve control solenoid valve				
C3★	(F42)	BR/2	: VIAS control solenoid valve				
D4★	(F43)	—	: Engine ground				
D4★	(F44)	—	: Engine ground				
F4★	(F100)	L/8	: To (F5)				
G5★	(F101)	G/8	: To (F6)				

- ★ : Be sure to connect and lock the connectors securely after repair work.
Failure to do so may cause the ECM to have diagnostic trouble codes.
- ★ : Do not disconnect these connectors except in the case of working according to WORK FLOW of TROUBLE DIAGNOSES in EC, AT and TF sections.

GI
MA
EM
LC
EC
FE
AT
TF
PD
AX
SU
BR
ST
RS
BT
HA
SC
EL
IDX

MEL078M

HARNES LAYOUT

Body Harness LH

Body Harness LH

NBEL0136

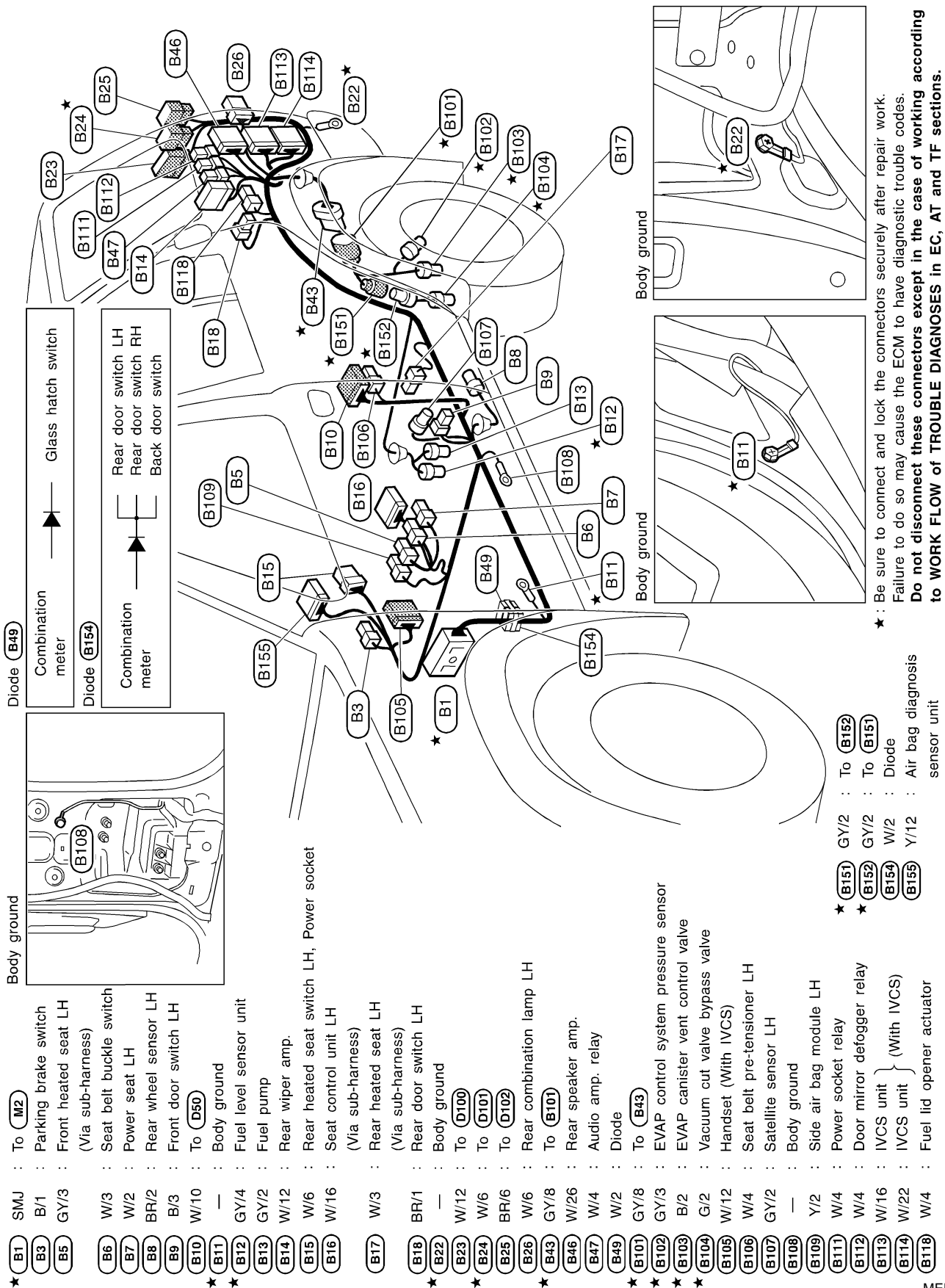

MEL079M

Body Harness RH

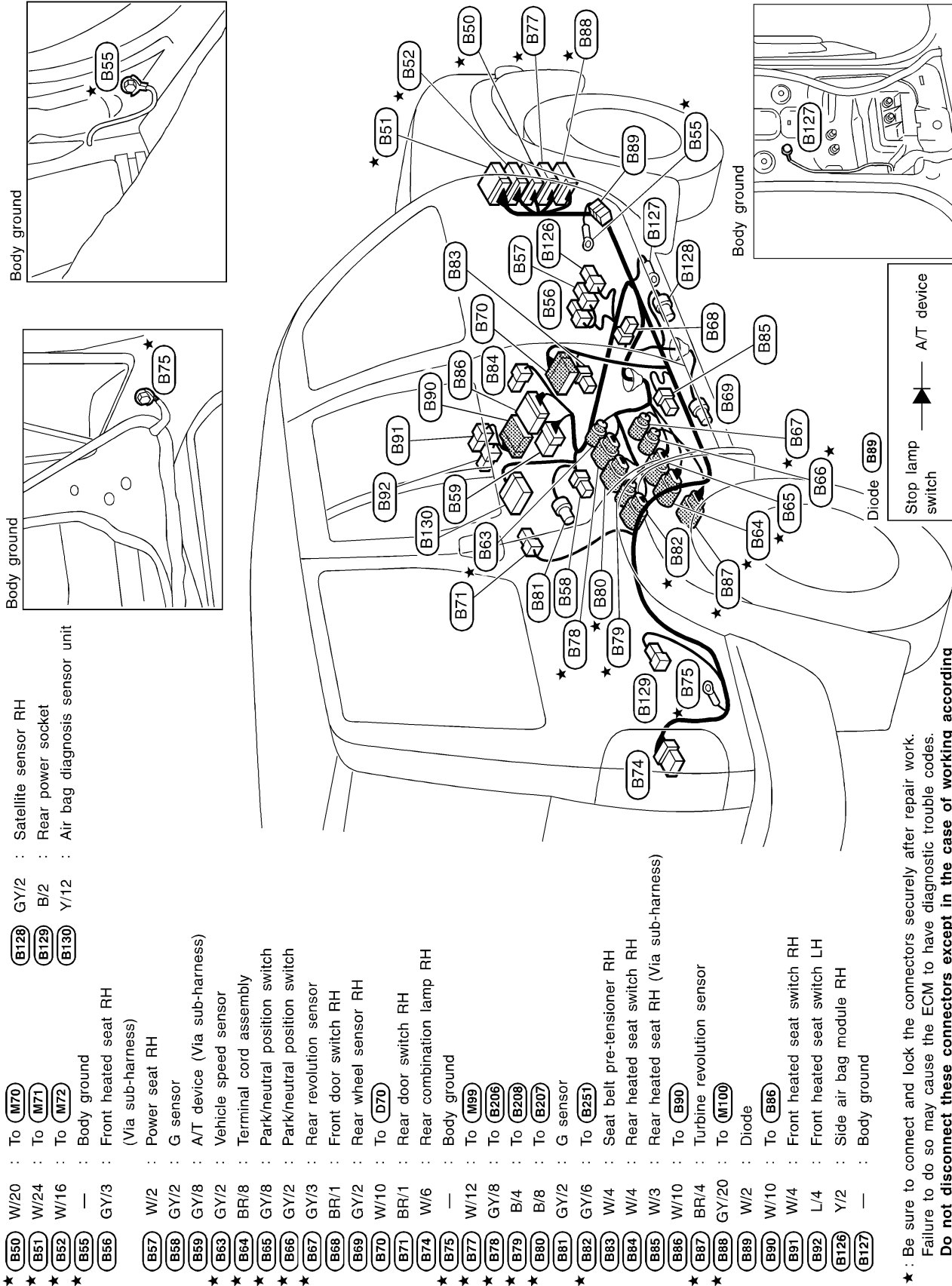

- ★ (B50) W/20 : To (M70)
- ★ (B51) W/24 : To (M71)
- ★ (B52) W/16 : To (M72)
- ★ (B55) — : Body ground
- (B56) GY/3 : Front heated seat RH (Via sub-harness)
- (B57) W/2 : Power seat RH
- (B58) GY/2 : G sensor
- (B59) GY/8 : A/T device (Via sub-harness)
- ★ (B63) GY/2 : Vehicle speed sensor
- ★ (B64) BR/8 : Terminal cord assembly
- ★ (B65) GY/8 : Park/neutral position switch
- ★ (B66) GY/2 : Park/neutral position switch
- ★ (B67) GY/3 : Rear revolution sensor
- (B68) BR/1 : Front door switch RH
- (B69) GY/2 : Rear wheel sensor RH
- (B70) W/10 : To (D70)
- (B71) BR/1 : Rear door switch RH
- (B74) W/6 : Rear combination lamp RH
- ★ (B75) — : Body ground
- ★ (B77) W/12 : To (M99)
- ★ (B78) GY/8 : To (B206)
- ★ (B79) B/4 : To (B208)
- ★ (B80) B/8 : To (B207)
- ★ (B81) GY/2 : G sensor
- ★ (B82) GY/6 : To (B251)
- (B83) W/4 : Seat belt pre-tensioner RH
- (B84) W/4 : Rear heated seat switch RH
- (B85) W/3 : Rear heated seat RH (Via sub-harness)
- ★ (B86) W/10 : To (B90)
- ★ (B87) BR/4 : Turbine revolution sensor
- ★ (B88) GY/20 : To (M100)
- (B89) W/2 : Diode
- (B90) W/10 : To (B86)
- (B91) W/4 : Front heated seat switch RH
- (B92) L/4 : Front heated seat switch LH
- (B126) Y/2 : Side air bag module RH
- (B127) — : Body ground

- (B128) GY/2 : Satellite sensor RH
- (B129) B/2 : Rear power socket
- (B130) Y/12 : Air bag diagnosis sensor unit

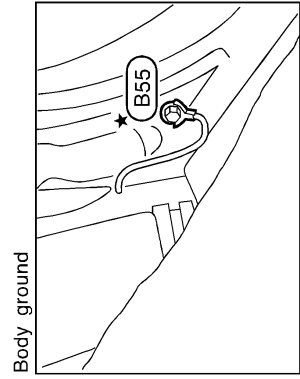
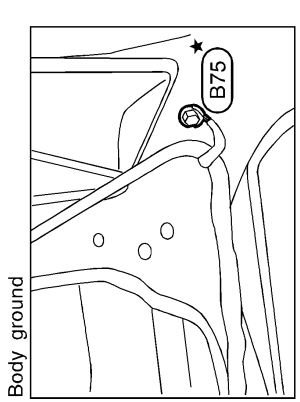

★ : Be sure to connect and lock the connectors securely after repair work.
 Failure to do so may cause the ECM to have diagnostic trouble codes.
 Do not disconnect these connectors except in the case of working according to WORK FLOW of TROUBLE DIAGNOSES in EC, AT and TF sections.

GI
 MA
 EM
 LC
 EC
 FE
 AT
 TF
 PD
 AX
 SU
 BR
 ST
 RS
 BT
 HA
 SC
EL
 IDX

HARNESS LAYOUT

Back Door Harness

Back Door Harness

NBEL0138

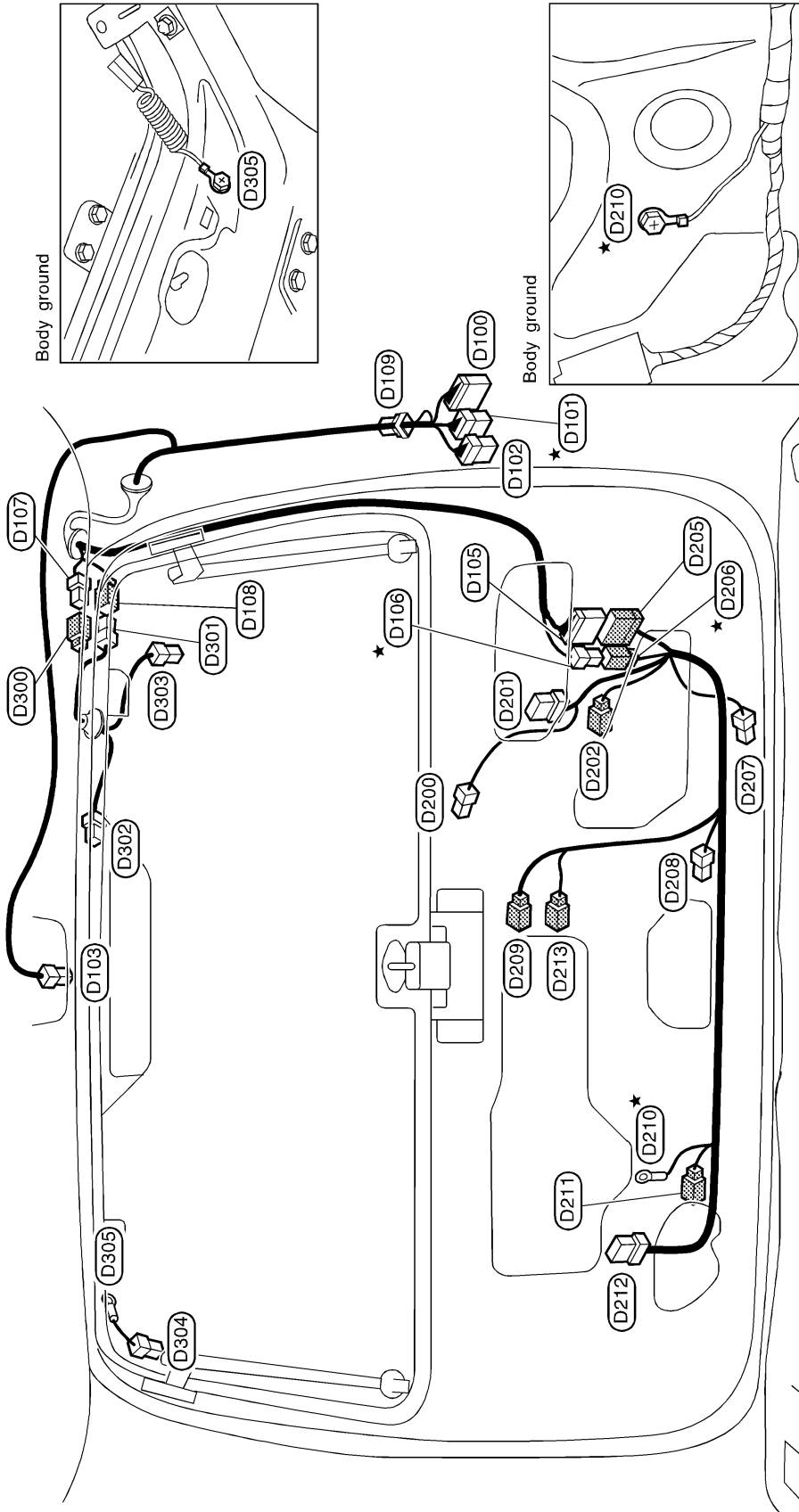

- D303 B/1 : Rear window defogger
- D304 B/1 : Rear window defogger
- D305 — : Body ground
- Diode (D109)

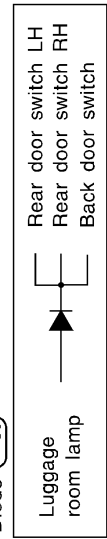

★ : Be sure to connect and lock the connectors securely after repair work.
 Failure to do so may cause the ECM to have diagnostic trouble codes.
Do not disconnect these connectors except in the case of working according to WORK FLOW of TROUBLE DIAGNOSES in EC, AT and TF sections.

- (D205) W/16 : To (D105)
- (D206) W/4 : To (D106)
- (D207) W/4 : Back door lock actuator
- (D208) W/2 : Back door switch
- (D209) W/2 : Glass hatch switch
- (D210) — : Body ground
- (D211) W/3 : License plate lamp RH
- (D212) W/8 : Rear wiper motor
- (D213) W/3 : Back door handle switch
- (D300) W/2 : To (D107)
- (D301) W/1 : To (D108)
- (D302) W/3 : High-mounted stop lamp

- (D100) W/12 : To (B23)
- (D101) W/6 : To (B24)
- (D102) BR/6 : To (B25)
- (D103) W/3 : Luggage room lamp
- (D105) W/16 : To (D205)
- (D106) W/4 : To (D206)
- (D107) W/2 : To (D300)
- (D108) W/1 : To (D301)
- (D109) W/2 : Diode
- (D200) W/4 : Glass hatch opener actuator
- (D201) W/6 : Back door key cylinder switch
- (D202) W/3 : License plate lamp LH

HARNESS LAYOUT

Engine and Transmission Harness

Engine and Transmission Harness

NBEL0139

GI
MA
EM
LC
EC
FE
AT
TF
PD
AX
SU
BR
ST
RS
BT
HA
SC
EL
IDX

★ : Be sure to connect and lock the connectors securely after repair work.
Failure to do so may cause the ECM to have diagnostic trouble codes.
Do not disconnect these connectors except in the case of working according to WORK FLOW of TROUBLE DIAGNOSES in EC, AT and TF sections.

- ★ (B206) GY/8 : To (B78)
 - ★ (B207) B/8 : To (B80)
 - ★ (B208) B/4 : To (B79)
 - ★ (B209) GY/8 : Terminal cord assembly
 - ★ (B210) GY/2 : ATP switch
 - ★ (B211) B/2 : Wait detection switch
 - ★ (B212) B/2 : Transfer motor
 - ★ (B213) BR/2 : Neutral-4LO switch
 - ★ (B214) GY/3 : Front revolution sensor (Transfer)
 - ★ (B251) GY/6 : To (B82)
 - ★ (B252) GY/6 : Transfer control device
- (With 4-wheel drive)

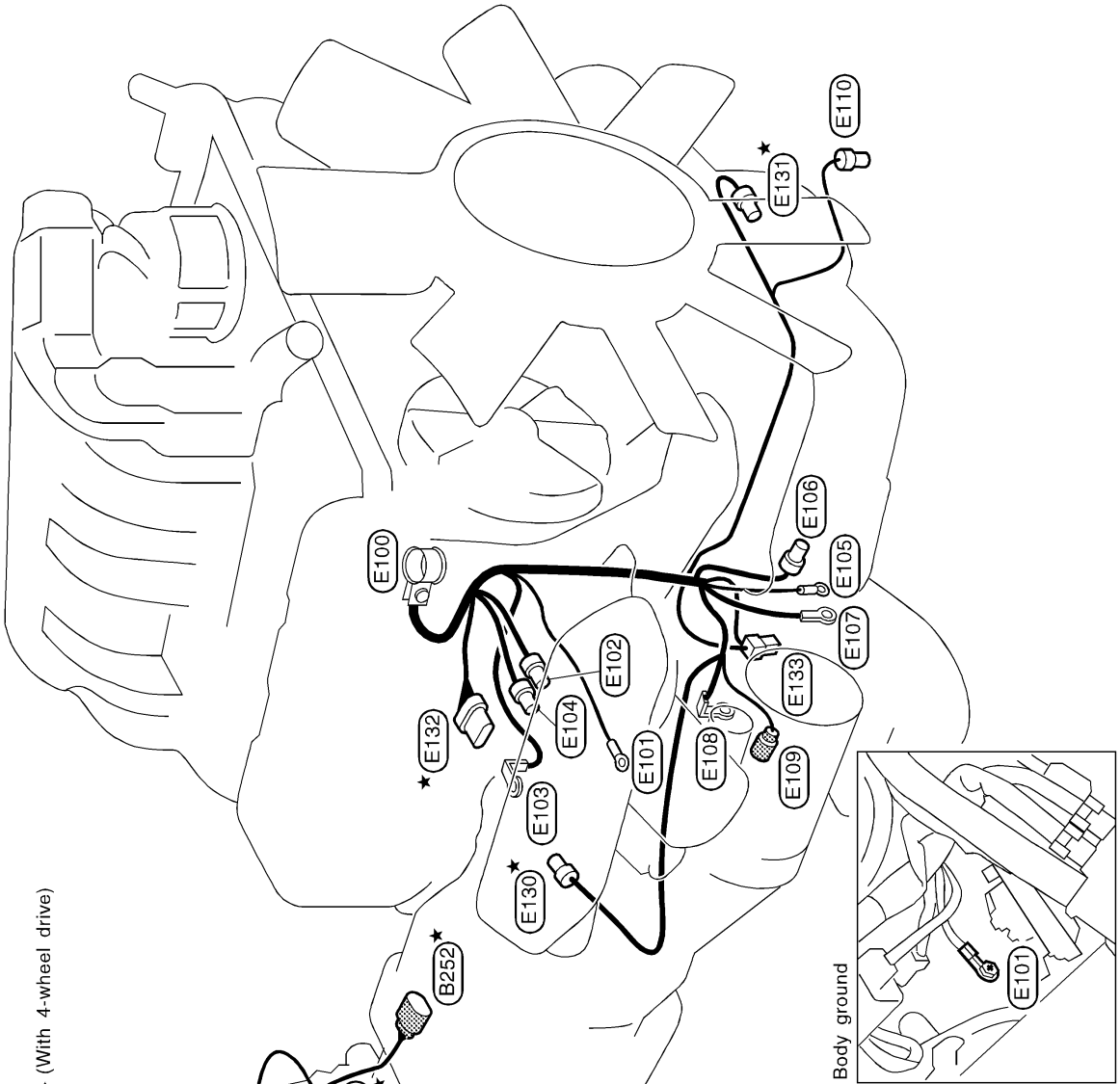

- (E100) - : Battery
- (E101) - : Body ground
- (E102) GY/4 : To (E48)
- (E103) - : Fuse and fusible link box
- (E104) GY/1 : To (E49)
- (E105) - : Alternator
- (E106) GY/2 : Alternator
- (E107) - : Alternator
- (E108) - : Starter motor
- (E109) GY/1 : Starter motor
- (E110) B/2 : Power steering oil pressure switch
- ★ (E130) GY/3 : Crankshaft position sensor (POS)
- ★ (E131) GY/2 : Crankshaft position sensor (REF)
- ★ (E132) GY/8 : To (E135)
- (E133) B/1 : Oil pressure switch

HARNESS LAYOUT

Room Lamp Harness

Room Lamp Harness

NBEL0140

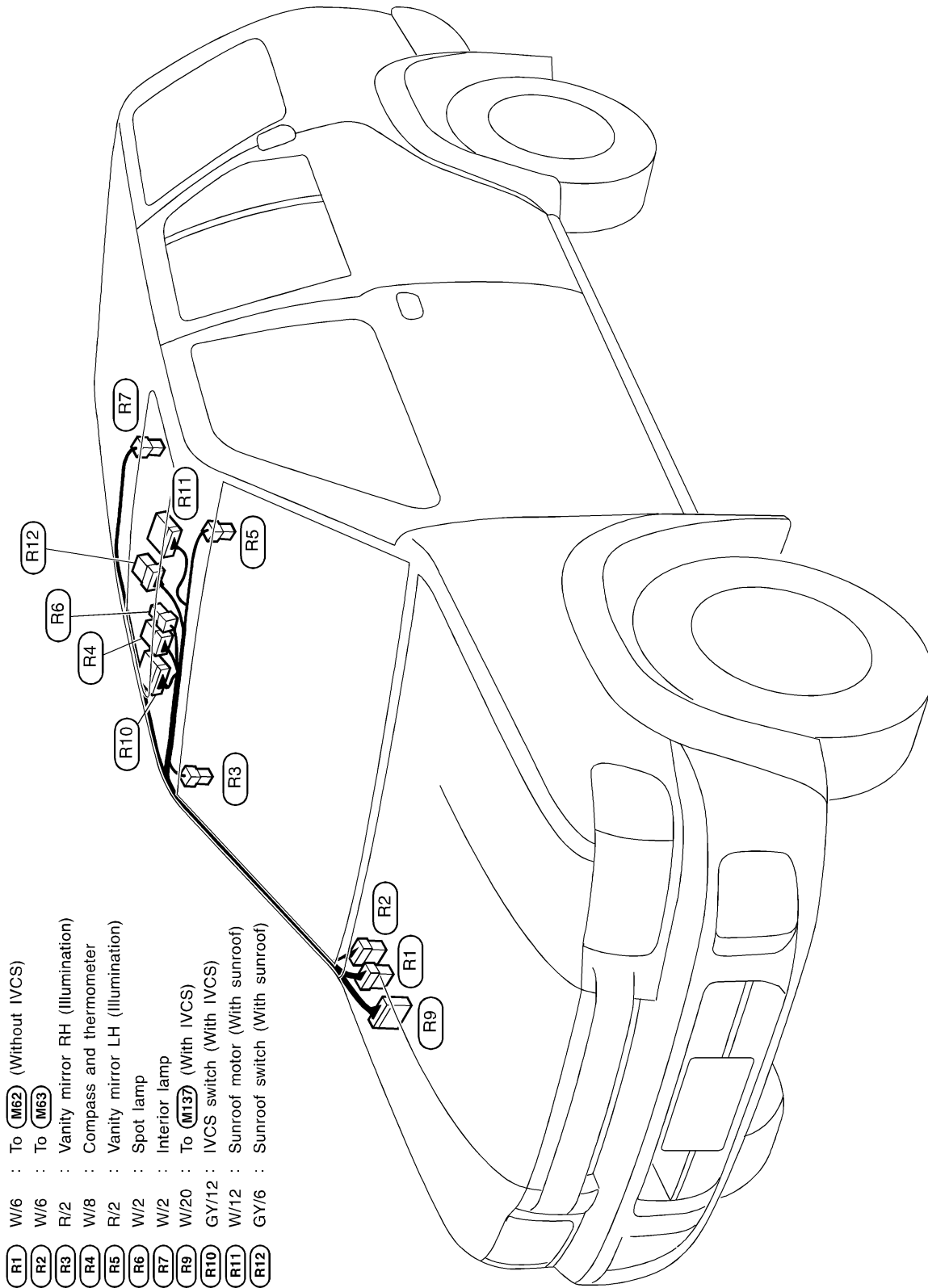

MEL083M

HARNESS LAYOUT

Air Bag Harness

Air Bag Harness

NBEL0141

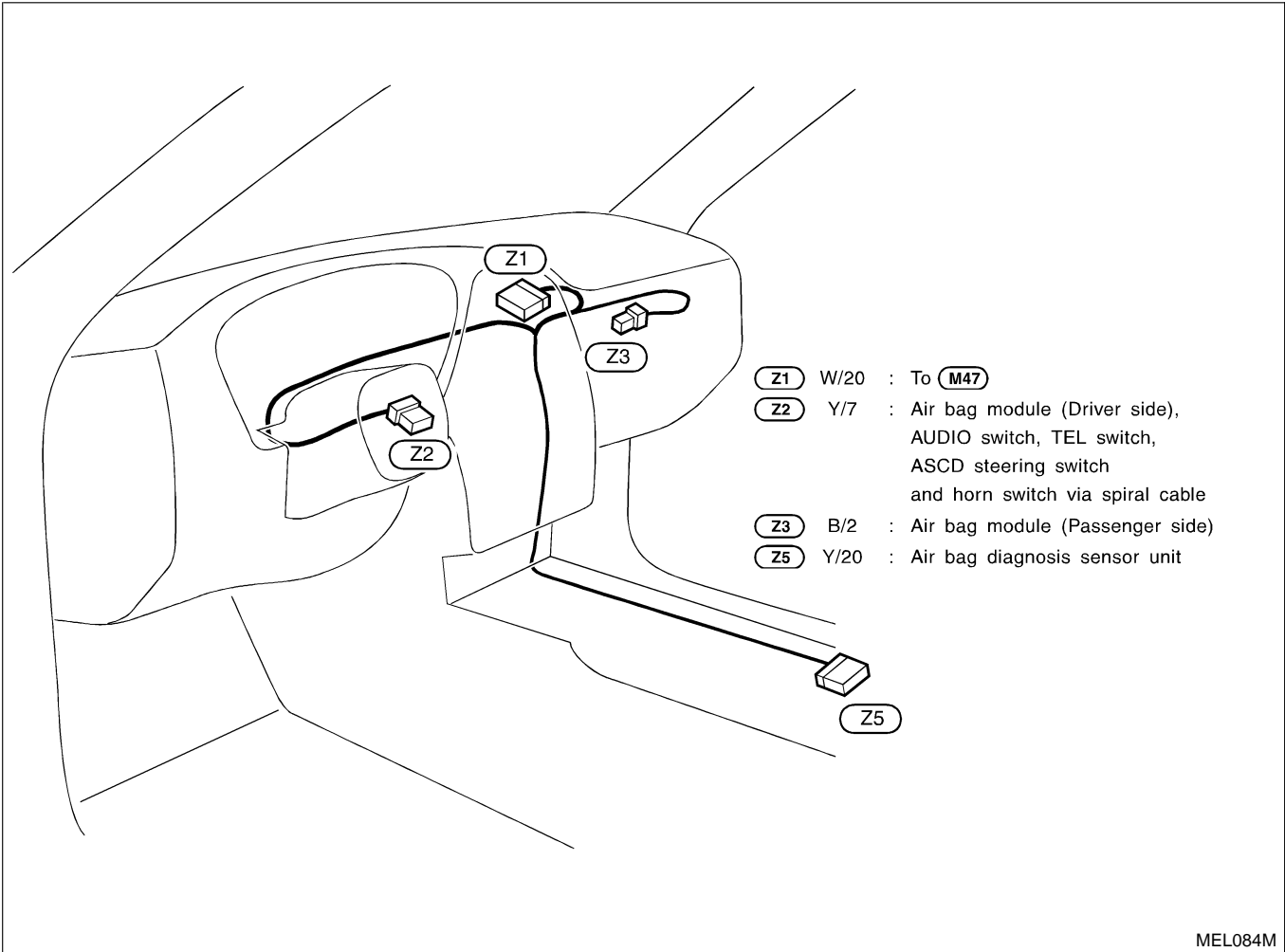

GI

MA

EM

LC

EC

FE

AT

TF

PD

AX

SU

BR

ST

RS

BT

HA

SC

EL

IDX

HARNESS LAYOUT

Front Door Harness

Front Door Harness

NBEL0142

LH side

- D1** GY/5 : Door mirror defogger LH
- D2** BR/3 : Door mirror LH
- D3** BR/20 : To **M5**
- D4** W/10 : To **M6**
- D5** GY/6 : Front power window regulator LH
- D6** W/16 : Power window main switch
- D7** GY/4 : Front door lock actuator LH
- D9** BR/3 : Front door key cylinder switch LH
- D12** W/6 : Front door speaker LH
- D13** GY/12 : To **M112**
- D14** W/4 : Fuel filler lid and glass hatch opener switch
- D15** W/3 : Power window main switch
- D16** W/8 : Seat memory switch

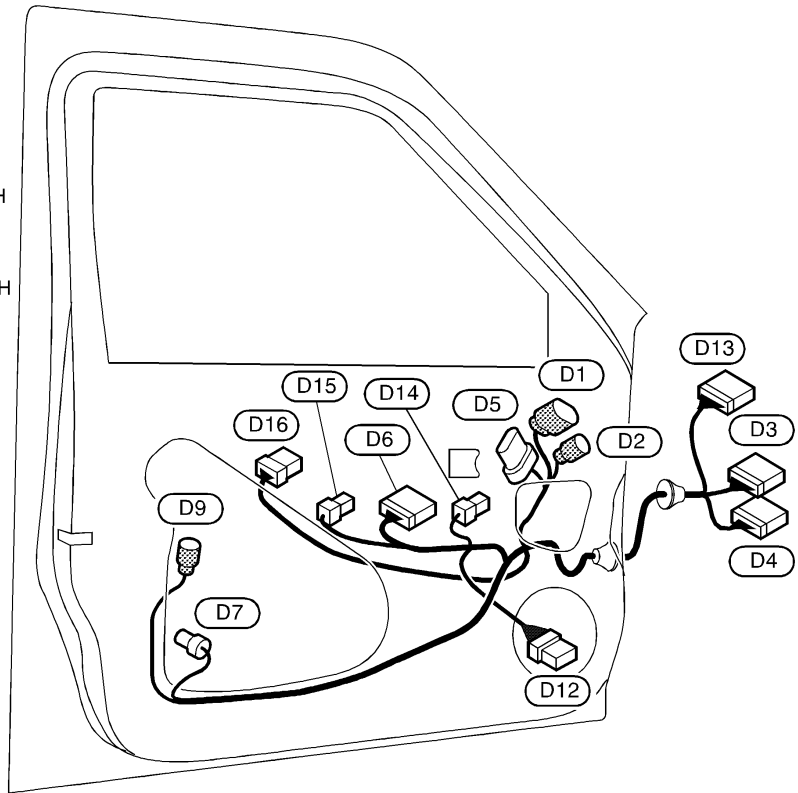

RH side

- D31** GY/5 : Door mirror defogger RH
- D32** BR/3 : Door mirror RH
- D33** BR/16 : To **M67**
- D34** W/6 : To **M68**
- D35** GY/6 : Front power window regulator RH
- D36** W/12 : Front power window switch RH
- D37** GY/4 : Front door lock actuator RH
- D41** BR/6 : To **M101**
- D42** W/6 : Front door speaker RH
- D43** W/8 : Front power window switch RH

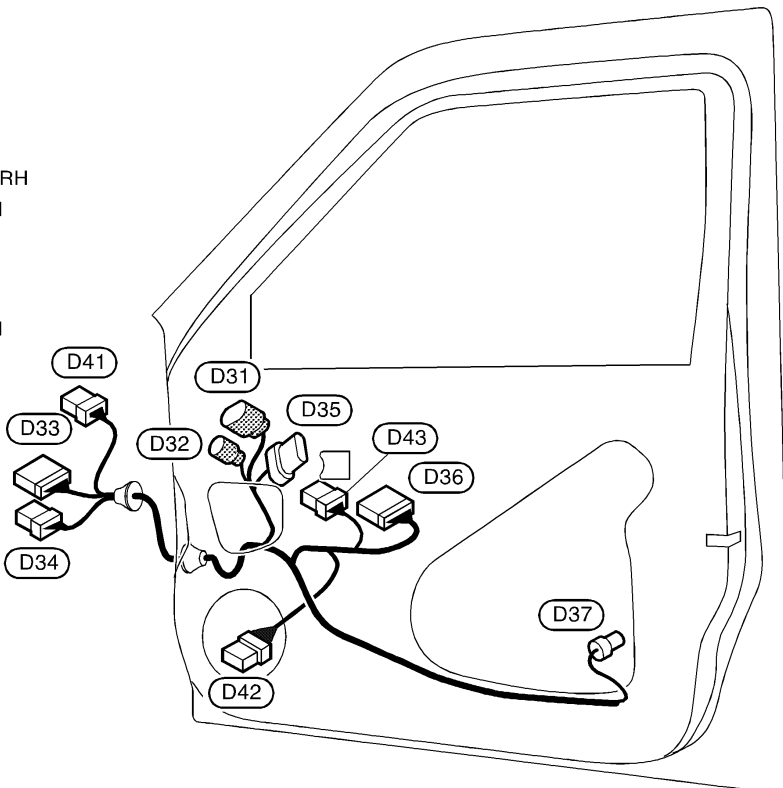

MEL085M

HARNES LAYOUT

Rear Door Harness

Rear Door Harness

NBEL0143

LH side

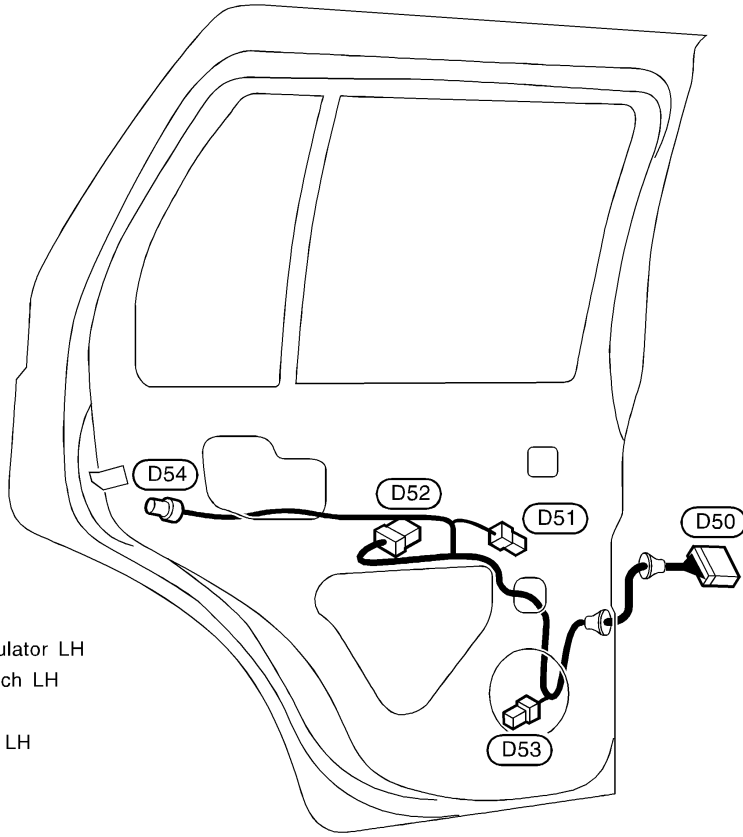

- (D50) W/10 : To (B10)
- (D51) B/2 : Rear power window regulator LH
- (D52) W/8 : Rear power window switch LH
- (D53) BR/2 : Rear door speaker LH
- (D54) GY/4 : Rear door lock actuator LH

RH side

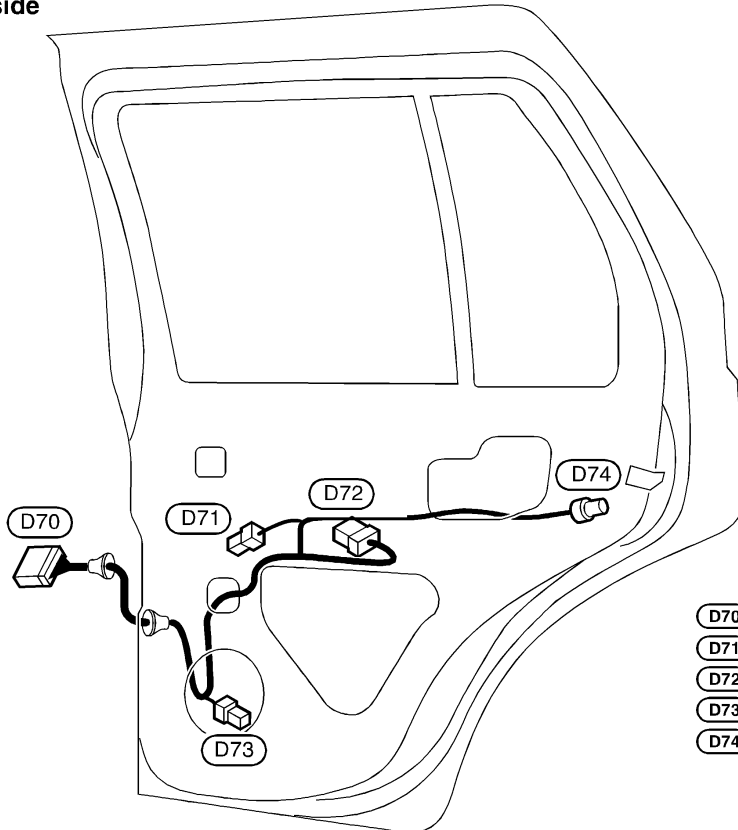

- (D70) W/10 : To (B70)
- (D71) B/2 : Rear power window regulator RH
- (D72) W/8 : Rear power window switch RH
- (D73) BR/2 : Rear door speaker RH
- (D74) GY/4 : Rear door lock actuator RH

GI

MA

EM

LC

EC

FE

AT

TF

PD

AX

SU

BR

ST

RS

BT

HA

SC

EL

IDX

MEL261M

BULB SPECIFICATIONS*Headlamp***Headlamp**

NBEL0144S03

Item	Wattage W
High/Low (Semi-sealed beam)	55/35 (HB3/D2R)

Exterior Lamp

NBEL0144S01

Item	Wattage W	
Front fog lamp	55	
Front turn signal lamp	21	
Parking lamp	5	
Rear combination lamp	Turn signal lamp	27
	Stop/Tail lamp	21/5
Back-up lamp	18	
License plate lamp	3.8	
High-mounted stop lamp	5	

Interior Lamp

NBEL0144S02

Item	Wattage W
Interior lamp	10
Spot lamp	8
Luggage room lamp	10

WIRING DIAGRAM CODES (CELL CODES)

Use the chart below to find out what each wiring diagram code stands for. Refer to the wiring diagram code in the alphabetical index to find the location (page number) of each wiring diagram.

Code	Section	Wiring Diagram Name
1STSIG	AT	A/T 1ST Signal
2NDSIG	AT	A/T 2ND Signal
3RDSIG	AT	A/T 3RD Signal
4THSIG	AT	A/T 4TH Signal
A/C, A	HA	Auto Air Conditioner
AAC/V	EC	IACV-AAC Valve
ABS	BR	Anti-lock Brake System
AP/SEN	EC	Absolute Pressure Sensor
ASCD	EL	Automatic Speed Control Device
AT/C	EC	A/T Control
ATDIAG	EC	A/T Diagnosis Communication Line
AT/IND	EL	A/T Indicator Lamp
AUDIO	EL	Audio
AUT/DP	EL	Automatic Drive Positioner
BA/FTS	AT	A/T Fluid Temperature Sensor and TCM Power Supply
BACK/L	EL	Back-up Lamp
BYPS/V	EC	Vacuum Cut Valve Bypass Valve
CHARGE	SC	Charging System
CHIME	EL	Warning Chime
CIGAR	EL	Cigarette Lighter
CLOCK	EL	Clock
COMPAS	EL	Compass and Thermometer
D/LOCK	EL	Power Door Lock
DEF	EL	Rear Window Defogger
DTRL	EL	Headlamp — With Daytime Light System —
ECTS	EC	Engine Coolant Temperature Sensor
ENGSS	AT	Engine Speed Signal
F/FOG	EL	Front Fog Lamp
F/LID	EL	Fuel Lid Opener
F/PUMP	EC	Fuel Pump Control
FICD	EC	IACV-FICD Solenoid Valve
FLS1	EC	Fuel Gauge

Code	Section	Wiring Diagram Name
FLS2	EC	Fuel Gauge
FLS3	EC	Fuel Gauge
FTS	AT	A/T Fluid Temperature Sensor
FUELLH	EC	Fuel Injection System Function (Left Bank)
FUELRH	EC	Fuel Injection System Function (Right Bank)
H/AIM	EL	Headlamp Aiming Control System
H/LAMP	EL	Headlamp
HORN	EL	Horn
HSEAT	EL	Heated Seat
IATS	EC	Intake Air Temperature Sensor
IGN/SG	EC	Ignition Signal
ILL	EL	Illumination
INJECT	EC	Injector
INT/L	EL	Interior, Spot, Vanity Mirror, and Luggage Room Lamps
IVC-L	EC	Intake Valve Timing Control Solenoid Valve LH
IVC-R	EC	Intake Valve Timing Control Solenoid Valve RH
IVCS	EL	INFINITI Communicator
IVCS-L	EC	Intake Valve Timing Control Position Sensor LH
IVCS-R	EC	Intake Valve Timing Control Position Sensor RH
KS	EC	Knock Sensor
LAN	AT	A/T Communication Line
LOAD	EC	Electrical Load Signal
LPSV	AT	Line Pressure Solenoid Valve
MAFS	EC	Mass Air Flow Sensor
MAIN	AT	Main Power Supply and Ground Circuit
MAIN	EC	Main Power Supply and Ground Circuit
METER	EL	Speedometer, Tachometer, Temp., Oil, and Fuel Gauges
MIL/DL	EC	MIL and Data Link Connectors
MIRROR	EL	Door Mirror
MULTI	EL	Multi-remote Control System
NATS	EL	IVIS (Infiniti Vehicle Immobiliser System)

GI
MA
EM
LC
EC
FE
AT
TF
PD
AX
SU
BR
ST
RS
BT
HA
SC
EL
IDX

WIRING DIAGRAM CODES (CELL CODES)

Code	Section	Wiring Diagram Name
NAVI	EL	Navigation System
NONDTC	AT	Non-detectable Items
O2H1B1	EC	Heated Oxygen Sensor 1 Heater (Front) (Bank 1)
O2H1B2	EC	Heated Oxygen Sensor 1 Heater (Front) (Bank 2)
O2H2B1	EC	Heated Oxygen Sensor 2 Heater (Rear) (Bank 1)
O2H2B2	EC	Heated Oxygen Sensor 2 Heater (Rear) (Bank 2)
O2S1B1	EC	Heated Oxygen Sensor 1 (Front) (Bank 1)
O2S1B2	EC	Heated Oxygen Sensor 1 (Front) (Bank 2)
O2S2B1	EC	Heated Oxygen Sensor 2 (Rear) (Bank 1)
O2S2B2	EC	Heated Oxygen Sensor 2 (Rear) (Bank 2)
OVRCSV	AT	Overrun Clutch Solenoid Valve
P/ANT	EL	Power Antenna
PGC/V	EC	EVAP Canister Purge Volume Control Solenoid Valve
PHASE	EC	Camshaft Position Sensor (PHASE)
PNP/SW	EC	Park/Neutral Position Switch
PNP/SW	AT	Park/Neutral Position Switch
POS	EC	Crankshaft Position Sensor (CKPS) (POS)
POWER	EL	Power Supply Routing
PRE/SE	EC	EVAP Control System Pressure Sensor
PST/SW	EC	Power Steering Oil Pressure Switch
REF	EC	Crankshaft Position Sensor (CKPS) (REF)
REMOTE	EL	Audio (Remote Control Switch)
RP/SEN	EC	Refrigerant Pressure
S/SIG	EC	Start Signal
S/VCSW	EC	Swirl Control Valve Control Vacuum Check Switch
SEAT	EL	Power Seat
SHIFT	AT	A/T Shift Lock System
SROOF	EL	Sunroof
SRS	RS	Supplemental Restraint System

Code	Section	Wiring Diagram Name
SSV/A	AT	Shift Solenoid Valve A
SSV/B	AT	Shift Solenoid Valve B
START	SC	Starting System
STOP/L	EL	Stop lamp
SWL/V	EC	Swirl Control Valve Control Solenoid Valve
TAIL/L	EL	Parking, License and Tail Lamps
TCCSIG	AT	A/T TCC Signal (Lock up)
TCV	AT	Torque Converter Clutch Solenoid Valve
T/F	TF	Transfer
TFTS	EC	Tank Fuel Temperature Sensor
THEFT	EL	Theft Warning System
TLID	EL	Glass Hatch Opener
TP/SW	EC	Throttle Position Switch
TPS	AT	Throttle Position Sensor
TPS	EC	Throttle Position Sensor
TRNSMT	EL	Integrated HOMELINK™ Transmitter
TRSA/T	AT	Turbine Revolution Sensor
TURN	EL	Turn Signal and Hazard Warning Lamps
VIAS/V	EC	Variable Induction Air Control System
VSS	EC	Vehicle Speed Sensor
VSSA/T	AT	Vehicle Speed Sensor A/T (Revolution Sensor)
VSSMTR	AT	Vehicle Speed Sensor MTR
WARN	EL	Warning Lamps
WINDOW	EL	Power Window
WIP/R	EL	Rear Wiper and Washer
WIPER	EL	Front Wiper and Washer